

visual engineering
LIGHTWARE

User's Manual



UMX-OPT-TX150R

Fiber Optical Multimedia Extender

Important Safety Instructions

Class II apparatus construction.

The equipment should be operated only from the power source indicated on the product.

To disconnect the equipment safely from power, remove the power cord from the rear of the equipment, or from the power source. The MAINS plug is used as the disconnect device, the disconnect device shall remain readily operable.

There are no user-serviceable parts inside of the unit. Removal of the cover will expose dangerous voltages. To avoid personal injury, do not remove the cover. Do not operate the unit without the cover installed.

The appliance must be safely connected to multimedia systems. Follow instructions described in this manual.qqqq

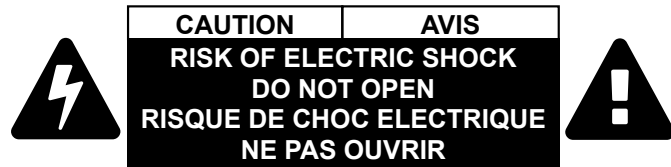

Ventilation

For the correct ventilation and to avoid overheating ensure enough free space around the appliance. Do not cover the appliance, let the ventilation holes free and never block or bypass the ventilators (if any).

WARNING

To prevent injury, the apparatus is recommended to securely attach to the floor/wall or mount in accordance with the installation instructions. The apparatus shall not be exposed to dripping or splashing and that no objects filled with liquids, such as vases, shall be placed on the apparatus. No naked flame sources, such as lighted candles, should be placed on the apparatus.

Waste Electrical & Electronic Equipment WEEE

This marking shown on the product or its literature, indicates that it should not be disposed with other household wastes at the end of its working life. To prevent possible harm to the environment or human health from uncontrolled waste disposal, please separate this from other types of wastes and recycle it responsibly to promote the sustainable reuse of material resources. Household users should contact either the retailer where they purchased this product, or their local government office, for details of where and how they can take this item for environmentally safe recycling. Business users should contact their supplier and check the terms and conditions of the purchase contract. This product should not be mixed with other commercial wastes for disposal.

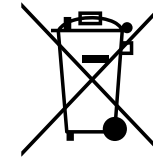

Caution: Laser product

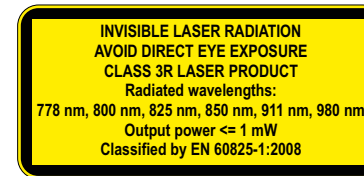

Common Safety Symbols

Symbol	Description
	Direct current
	Alternating current
	Double insulation
	Caution, possibility of electric shock
	Caution
	Laser radiation

Symbol Legend

The following symbols and markings are used in the document:

WARNING! Safety-related information which is highly recommended to read and keep in every case!

ATTENTION! Useful information to perform a successful procedure; it is recommended to read.

INFO: A notice which may contain additional information. Procedure can be successful without reading it.

TIPS AND TRICKS: Ideas which you may have not known yet but can be useful.

Navigation Buttons

 Go back to the previous page. If you clicked on a link previously, you can go back to the source page by the button.

 Navigate to the Table Contents.

 Step back one page.

 Step forward to the next page.

Document Information

This User's Manual applies to the following versions of the mentioned software, firmware, and hardware:

Item	Version
Lightware Device Controller (LDC) software	1.14.0b3
Lightware Device Updater (LDU) software	1.3.4b4
Controller firmware	1.0.4
Hardware	1.1

Document revision: **3.0**

Release date: 01-09-2017

Editor: Judit Barsony

Table of Contents

1. INTRODUCTION	6	4.6. AUDIO AUTOSELECT MODE	18	5.6. EDID MENU	31
1.1. DESCRIPTION.....	6	4.6.1. Static Select.....	18	5.6.1. EDID Operations.....	31
1.2. BOX CONTENTS.....	6	4.6.2. Non-Priority (First Detect).....	18	5.6.2. EDID Summary Window.....	32
1.3. COMPATIBLE DEVICES.....	6	4.6.3. Priority Detect.....	19	5.6.3. Editing an EDID.....	32
1.4. FEATURES OF THE DEVICE.....	7	4.6.4. Fix Selection.....	19	5.6.4. Creating an EDID.....	33
1.5. TYPICAL APPLICATION.....	8	4.7. EDID MANAGEMENT	19	5.7. SETTINGS MENU	33
2. INSTALLATION	9	4.7.1. EDID Memory Structure.....	20	5.7.1. DEVICE INFORMATION	33
2.1. MOUNTING OPTIONS.....	9	4.7.2. Deleting the EDID.....	21	5.7.2. Status.....	33
2.2. CONNECTING STEPS.....	10	4.7.3. EDID Types.....	21	5.7.3. Log.....	33
2.3. CONNECTION OF SERIAL DEVICES.....	10	4.7.4. EDID Learning.....	22	5.8. TERMINAL WINDOW	34
2.3.1. GENERAL INFORMATION.....	10	4.7.5. EDID Switching.....	22	6. LW2 PROGRAMMERS' REFERENCE	35
2.3.2. Types of Serial Cables.....	11	4.8. HDCP MANAGEMENT	22	6.1. SERIAL PORT SETTINGS	35
2.3.3. CONNECTION DIAGRAM - EXAMPLES.....	11	4.9. RELOAD FACTORY DEFAULTS	22	6.2. LW2 PROTOCOL DESCRIPTION	35
2.3.4. Connecting Serial Devices.....	11	4.10. SERVICE MENU	23	6.3. STATUS AND IDENTIFICATION COMMANDS	36
3. PRODUCT OVERVIEW	12	4.10.1. Enter the Service Menu of UMX-OPT-TX150R.....	23	6.3.1. View Product Type.....	36
3.1. UMX-OPT-TX150R - FRONT VIEW.....	12	4.10.2. Service Menu Display and Navigation.....	23	6.3.2. View Serial Number.....	36
3.2. UMX-OPT-TX150R - REAR VIEW.....	13	4.10.3. Saving in the Service Menu.....	24	6.3.3. View Firmware Version of the CPU.....	36
3.3. ELECTRICAL CONNECTORS.....	14	4.10.4. Exit from Service Menu.....	24	6.3.4. View Installed Controllers' Firmware.....	36
3.3.1. DVI-I Input.....	14	4.11. REMOTE OPERATION	24	6.3.5. View Device's Temperature.....	36
3.3.2. VGA Input.....	14	4.11.1. Control Interfaces.....	24	6.3.6. View CPU Firmware Compile Time.....	36
3.3.3. HDMI Input.....	14	4.11.2. Multiple Simultaneous Connections.....	24	6.3.7. View Installed I/O Boards.....	36
3.3.4. Fiber Optical Output.....	14	4.11.3. RS-232 Operation Modes.....	24	6.3.8. Query All Port Status.....	37
3.3.5. Analog Audio Input.....	14	5. SOFTWARE CONTROL – LIGHTWARE DEVICE CONTROLLER ...26		6.4. SYSTEM COMMANDS	37
3.3.6. S/PDIF Input.....	14	5.1. INSTALL AND UPGRADE	26	6.4.1. Query Current Control Protocol.....	37
3.3.7. RS-232 Port.....	14	5.2. ESTABLISHING THE CONNECTION	27	6.4.2. Change RS-232 Baud Rate.....	37
3.3.8. USB Connector.....	14	5.3. CROSSPOINT MENU	27	6.4.3. Query RS-232 Baud Rate.....	37
3.3.9. DC 5V Connection.....	14	5.4. INPUT PARAMETERS SETTINGS WINDOW	28	6.4.4. Reload Factory Defaults.....	38
3.4. PORT DIAGRAM	15	5.4.1. Reload Factory Defaults.....	28	6.4.5. Set the RS-232 Operation Mode.....	38
4. OPERATION OF UMX-OPT-TX150R	16	5.4.2. General Settings.....	28	6.4.6. Query the RS-232 Operation Mode.....	38
4.1. BOOT UP OF UMX-OPT-TX150R.....	16	5.4.3. Input Port Status.....	28	6.4.7. Clear HDCP Key Cache.....	38
4.1.1. Firmware Indication.....	16	5.4.4. Video Signal Info.....	28	6.4.8. Count HDCP Keys.....	39
4.2. FRONT PANEL LEDs.....	16	5.4.5. Audio Signal Info.....	28	6.4.9. Restart Transmitter.....	39
4.3. REAR PANEL LEDs.....	17	5.4.6. Analog Video Options.....	28	6.4.10. View Error List.....	39
4.4. INPUT SELECTION.....	17	5.4.7. Frame Detector.....	29	6.4.11. Configure Remote Alerts.....	40
4.4.1. Video Input Selection.....	17	5.5. OUTPUT PARAMETERS SETTINGS WINDOW	30	6.4.12. Query Level of Remote Alerts.....	40
4.4.2. Audio Input Selection.....	17	5.5.1. Set Signal Properties.....	30	6.4.13. Set the Video Priority Settings.....	40
4.5. VIDEO AUTOSELECT MODE.....	17	5.5.2. General.....	30	6.4.14. Query the Video Priority Settings.....	40
4.5.1. Non-Priority (First Detect).....	17	5.5.3. Display.....	30	6.4.15. Set the Audio Priority Settings.....	41
4.5.2. HDMI Digital Priority.....	18	5.5.4. SUPPORTED AUDIO FORMATS	30	6.4.16. Query the Audio Priority Settings.....	41
4.5.3. DVI-D Digital Priority.....	18	5.5.5. Autoselect Settings.....	30	6.5. EDID ROUTER COMMANDS	41
		5.5.6. Optical Module Properties.....	30	6.5.1. Save EDID to User Memory (Learn EDID).....	41
				6.5.2. View Emulated EDIDs on All Inputs.....	41

- 6.5.3. Watch EDID Validity Table 41
- 6.5.4. View EDID Header..... 42
- 6.5.5. Download EDID Content from the Transmitter 42
- 6.5.6. Upload EDID Content from the Transmitter 42
- 6.5.7. Delete EDID from Memory 43
- 6.6. CONTROL COMMANDS 43**
- 6.6.1. Switch One Input to One Output 43
- 6.6.2. View All Connections on the Output 44
- 6.6.3. Query Autoselect State 44
- 6.7. ERROR LOG RELATED COMMANDS..... 44**
- 6.7.1. List a Directory..... 44
- 6.7.2. List the Log File 44
- 6.7.3. Clear the Log File..... 44
- 6.8. INPUT PROPERTIES 45**
- 6.8.1. Set Input Port Properties 45
- 6.8.2. Query Input Port Properties 46
- 6.8.3. Set Analog Timing Properties..... 47
- 6.8.4. Query Analog Timing Properties 47
- 6.8.5. Reset Analog Timing Properties..... 47
- 6.8.6. Set Analog Color Properties 47
- 6.8.7. Save Analog Color Properties..... 48
- 6.8.8. Query Analog Color Properties 48
- 6.8.9. Reset Analog Color Properties 48
- 6.8.10. Set Analog Input Audio Parameters..... 48
- 6.8.11. Query Analog Input Audio Properties..... 48
- 6.8.12. Set the No Sync Picture Properties 49
- 6.8.13. Query the No Sync Picture Properties..... 49
- 6.8.14. Query Timings of the Incoming Signal 49
- 6.8.15. Save Preset 50
- 6.8.16. Delete Preset 50
- 6.8.17. Delete All Presets 50
- 6.8.18. Clone Preset 50
- 6.8.19. List Presets 50
- 6.8.20. Delete Preset from All Input Ports..... 51
- 6.9. OUTPUT PROPERTIES 51**
- 6.9.1. Set Output Video Properties 51
- 6.9.2. Query Output Video Properties 52
- 6.10. ERROR RESPONSES 52**
- 6.11. LW2 COMMANDS - QUICK SUMMARY 52**
- 7. FIRMWARE UPGRADE 54**
- 7.1. INSTALL AND UPGRADE 54**
- 7.1.1. Establish the Connection 55
- 7.1.2. Start the LDU and Follow the Instructions..... 55

- 8. TROUBLESHOOTING 58**
- 9. TECHNOLOGIES 59**
- 9.1. EDID MANAGEMENT 59**
- 9.1.1. Understanding the EDID 59
- 9.1.2. Advanced EDID Management..... 59
- 9.2. HDCP MANAGEMENT 60**
- 9.2.1. Protected and Unprotected Content 60
- 9.2.2. Disable Unnecessary Encryption 60
- 9.3. PIXEL ACCURATE RECLOCKING 60**
- 10. APPENDIX 61**
- 10.1. SPECIFICATION 61**
- 10.2. FACTORY DEFAULT SETTINGS..... 62**
- 10.3. FACTORY EDID LIST 63**
- 10.4. MECHANICAL DRAWINGS 64**
- 10.5. ASCII TABLE 64**
- 10.6. FURTHER INFORMATION..... 65**

1

Introduction

Thank You for choosing Lightware UMX-OPT-TX150R monitor extender. The product is an all-round, universal video and audio transmitter for ever-changing environments such as small board and conference rooms. The extender was designed to handle digital and analog video and audio signals e.g. VGA, YPbPr, DVI and HDMI 1.3 with analog stereo, 5.1 S/PDIF and even 7.1 HDMI embedded audio.

In this first chapter of this manual we would like to introduce the device highlighting the most important features in the below listed sections:

- ▶ DESCRIPTION
- ▶ BOX CONTENTS
- ▶ COMPATIBLE DEVICES
- ▶ FEATURES OF THE DEVICE
- ▶ TYPICAL APPLICATION

1.1. Description

Lightware's UMX-OPT-TX150R is a universal video and audio transmitter. It was designed to handle digital and analog signals for both video and audio e.g. VGA, DVI and HDMI 1.3 with analog stereo, 5.1 S/PDIF and even 7.1 HDMI embedded audio.

Analog signals are converted to digital Formats with digital or digitized analog audio becoming embedded in the video stream. The UMX-OPT-TX150R handles HDCP encryption and has an HDCP enable/disable function.

Using factory, custom or transparent EDID emulation (separate rotary switches for VGA, DVI-A, DVI-D and HDMI inputs), the user can fix and lock EDID data on the transmitter's input connector. Advanced EDID Management forces the required resolution from any VGA or HDMI laptop and fixes the output Format conforming to the system requirement.

Control options available through RS-232: The UMX-OPT-TX150R can be controlled from either a touch controller or a control system. The transmitter has an RS-232 pass-through option which allows direct bidirectional communication between the touch controller and control system. For advanced users RS-232 baud rate can be manually configured by a rotary switch as well as by the control software.

Model Denomination

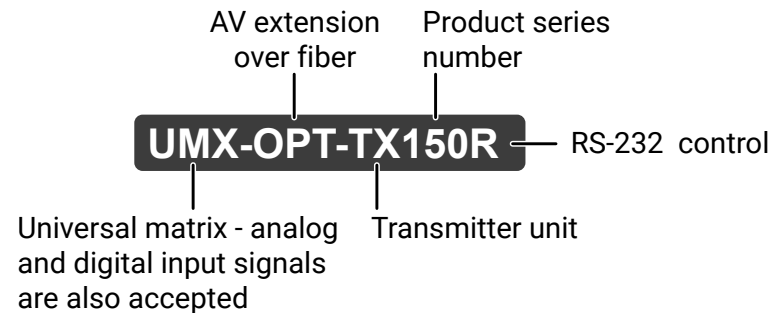

1.2. Box Contents

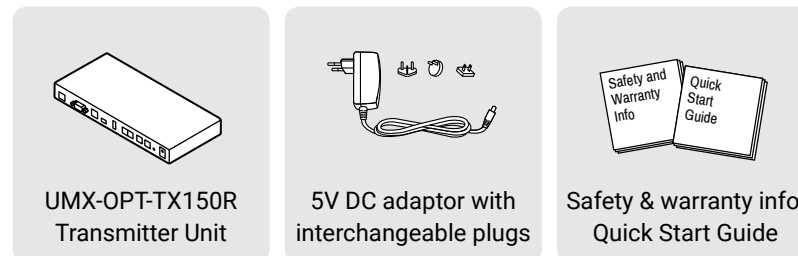

1.3. Compatible Devices

Cross compatibility between all the devices in the product series is ensured thanks to Lightware's attentive design. The transmitter can be paired with any receiver without restriction. With Lightware's Hybrid Modular Matrix concept, it is even possible to connect the UMX-OPT-TX150R directly to the matrix router using an MX-HDMI-OPT or MX-DVI-OPT series input board. You can see the list of compatible devices below:

Product name	Product group
DVIDL-OPT-RX100	DVIDL-OPT series
DVI-OPT-RX110	DVI-OPT-110 series
DVI-OPT-RX220-Pro	DVI-OPT-220 series
HDMI-3D-OPT-RX150RA	HDMI-3D-OPT series
HDMI-OPT-RX100	HDMI-OPT series
HDMI-OPT-RX100R	HDMI-OPT series
HDMI-OPT-RX200R	HDMI-OPT series
MX-DVI-OPT-IB	MX Boards
MX-HDMI-OPT-IB	MX Boards

1.4. Features of the Device



HDCP Compliant

UMX-OPT-TX150R complies with HDCP standard Lightware is a legal HDCP adopter. Both HDCP-encrypted and non-HDCP components can be installed in the same system. The included advanced HDCP management eliminates the need for re authentication upon switching.



Zero Frame Delay

Even on Analog Inputs - Lightware's UMX-OPT-TX150R add no frame noticeable delay to the switched signal. There is no frame or line period delays to the signals when passing a Lightware device.



Advanced EDID Management

The user can emulate any EDID on the inputs independently, read out and store any attached monitor's EDID in 100 internal memory locations, upload and download EDID files using Lightware Device Controller software.

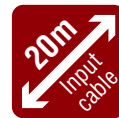

20 meters Input Cable Compensation

Using 22AWG high quality DVI or HDMI cable, the digital inputs are automatically compensated for up to 20 meters cable length at 24bpp, which extends installation possibilities even at the highest HDTV or computer resolutions.



Supports all HDTV Resolutions

720p, 1080i, 1080p 2K etc. HDTV signals up to 225 MHz pixel clock frequency are passed through regardless of the resolution.



Pixel Accurate Reclocking

Each output has a clean, jitter free signal, eliminating signal instability and distortion caused by long cables or connector reflections.



Frame Detector and Signal Analysis

The exact video and audio signal Format can be determined such as timing, frequencies, scan mode, HDCP encryption, color range, color space and audio sample rate.



Universal Power Adaptor

UMX-OPT-TX150R transmitter is equipped with a universal +5V DC power adaptor, which accepts AC voltages from 100 to 240 Volts with 50 or 60 Hz line frequency.



Separate Audio and Video Switching

Video and audio signals are separated and can be switched independently. Even if the HDMI stream contains embedded audio.

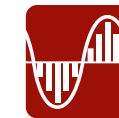

Analog Audio and Video A/D Conversion

UMX-OPT-TX150R converts uncompressed analog audio and video signal to digital and places it to the output.



Analog and Digital Audio Embedding

Accepts analog stereo; 5.1 S/PDIF and even 7.1 HDMI embedded audio signals. Analog signals are converted to digital Formats and digital or digitized analog audio can be embedded in the video stream.



Autoswitch Function for Video and Audio Inputs

Autoselect mode with or without priority can toggle between inputs. It helps the handling of the transmitter and installation of new devices.

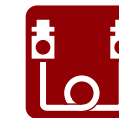

Single Fiber Technology

All of the high-speed TMDS data lanes are transmitted using only one multimode 50/125 (or 62.5/125) fiber optical cable.

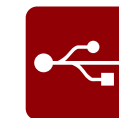

USB Control

Input status, Advanced EDID Management, Terminal Window and hardware information can be accessed with Lightware Device Controller software via USB connection.



Bidirectional RS-232 and Control

Input status, Advanced EDID Management, Terminal Window and hardware information can be accessed with Lightware Device Controller software via simple ASCII-based RS-232 protocol. Serial port passthrough supports any third-party unit that works with standard RS-232.

1.5. Typical Application

The typical application of the UMX-OPT-TX150R transmitter:

- Executive boardrooms
- Small classrooms
- Conference rooms, collaborative telepresence
- Multiroom video and audio control
- Home theatre systems

Standalone Application

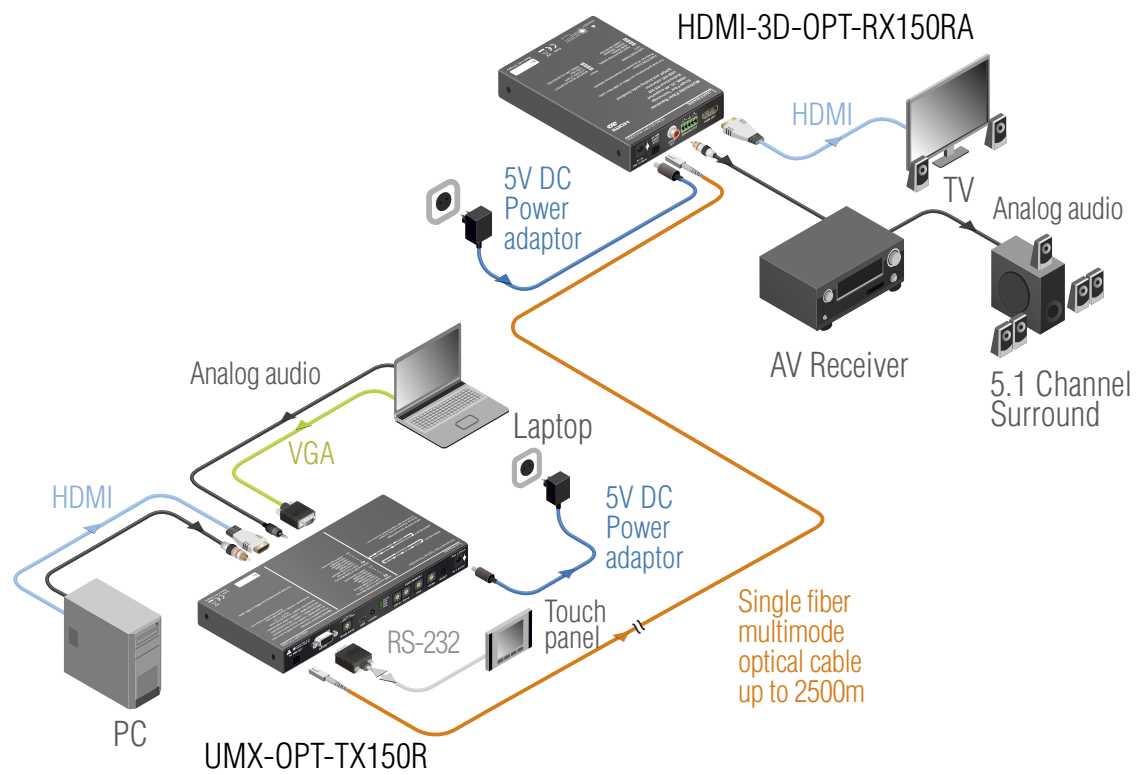

Integrated System Application

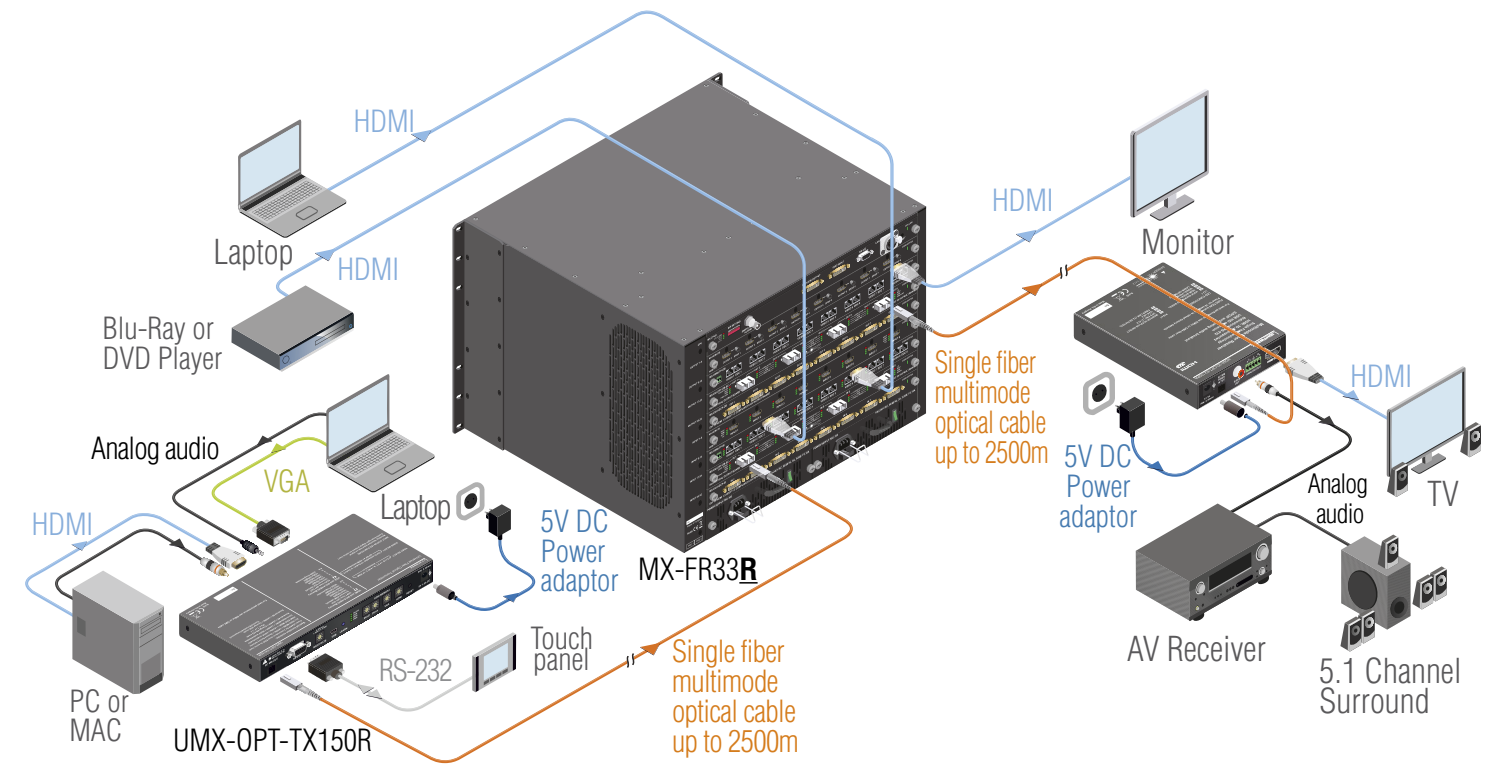

2

Installation

The chapter is about the installation of the device and connecting to other appliances, presenting also the mounting options and further assembly steps:

- ▶ [MOUNTING OPTIONS](#)
- ▶ [CONNECTING STEPS](#)
- ▶ [CONNECTION OF SERIAL DEVICES](#)

2.1. Mounting Options

To mount the extender Lightware supplies optional accessories for different usage. There are two kinds of mounting kits with similar fixing method. The device has two mounting holes with inner thread on the bottom side; see the bottom view in [Mechanical Drawings](#) section. Fasten the device by the screws enclosed to the accessory.



Under-desk double mounting kit



1U high rack shelf

The Under-desk double mounting kit makes easy to mount a single device on any flat surface, e.g. furniture. 1U high rack shelf provides mounting holes for fastening two half-rack or four quarter-rack sized units. Pocket-sized devices can also be fastened on the shelf. To order mounting accessories please contact sales@lightware.eu.

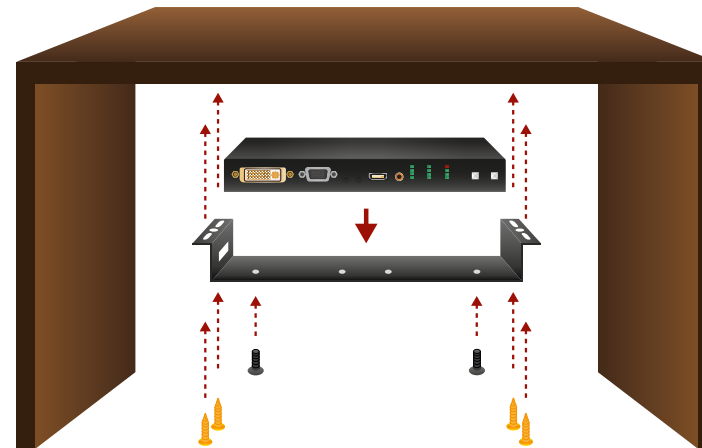

Installing the extender under the desk using Under-desk double mounting kit

INFO: The chipboard screws are not supplied with the mounting kit.

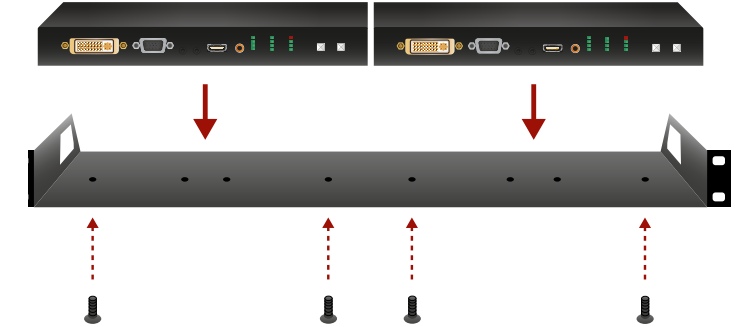

Mounting of two extenders to a 1U high rack shelf

WARNING! Always use the supplied screws. Using different (e.g. longer) ones may cause damage to the device.

ATTENTION! Always use all the four screws for fixing the rack shelf ears to the rack rail. Choose properly sized screws for mounting. Keep minimum two threads left after the nut screw.

INFO: The extender is half-rack sized.

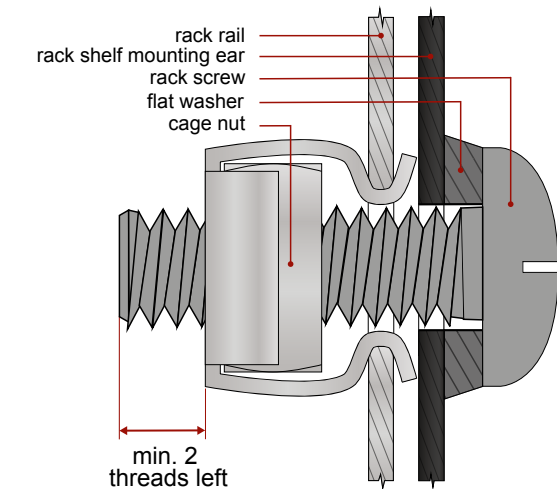

Mounting 1U high rack shelf to the rack rail

2.2. Connecting Steps

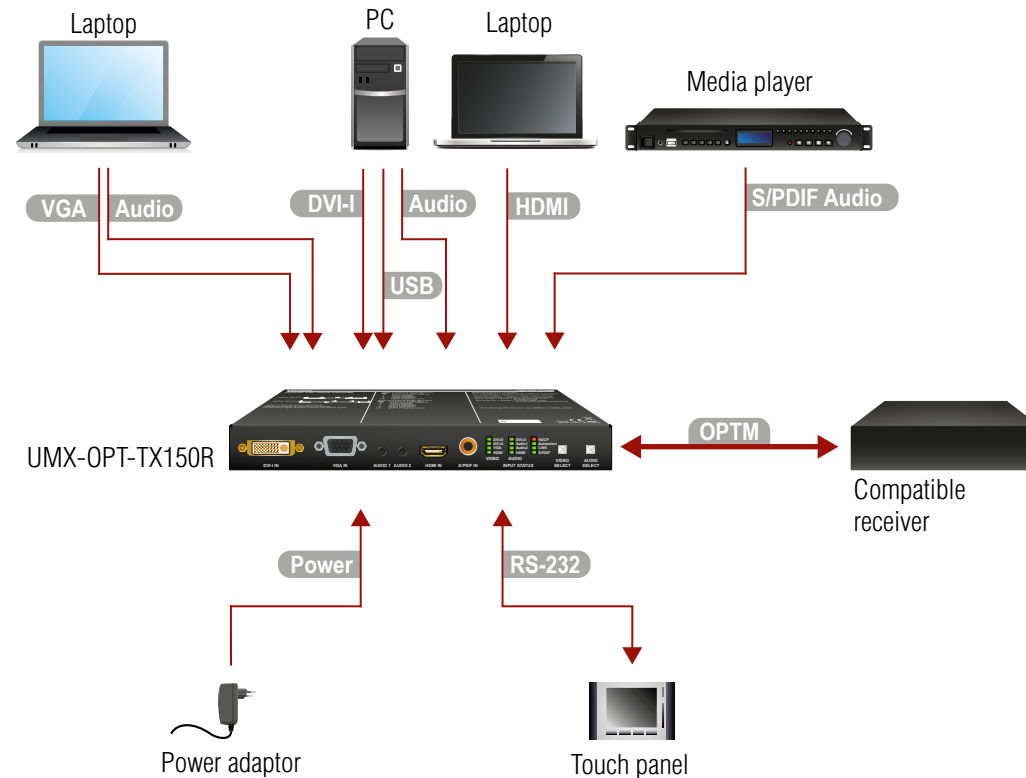

- VGA** Connect the transmitter and the sources using the proper VGA / DVI-I / HDMI cables.
- DVI**
- HDMI**
- Audio** Optionally connect an audio device (e.g. the VGA laptop) to the audio input port.
- S/PDIF Audio** Optionally connect a digital audio device (e.g. the Media player) to the S/PDIF audio input port.
- USB** Optionally connect a USB A – Mini USB B cable between the transmitter unit and the computer in order to control the device.

- OPTM** Connect a multimode (OPTM) fiber cable to the SC fiber output port of the transmitter to the SC fiber input port of the compatible receiver. See the list of the [Compatible Devices](#).
- RS-232** Optionally for RS-232 control: connect a controller/controlled device (e.g. Touch panel) to the RS-232 port.
- Power** Firstly connect the power adaptor to the DC input of the transmitter, then to the AC power socket.

WARNING! Please do not look directly into the SC fiber optical connector if the cable is connected to the transmitter only and the laser is active.

INFO: Powering the devices on is recommended to do as the final step during the installation.

2.3. Connection of Serial Devices

2.3.1. General Information

There are two types of devices in general serial communication:

- **Data Terminal Equipment:** Data Terminal Equipment (DTE) is an end instrument that converts user information into signals or reconverts received signals. Typical DTE devices: computers, LCD touch panels and control systems.
- **Data Circuit-terminating Equipment:** Data Circuit-terminating Equipment (DCE) is a device that sits between the DTE and a data transmission circuit. It is also called data communication equipment and data carrier equipment. Typical DCE devices: projectors, industrial monitors and amplifiers.

Among others the pin assignment is different between DTE and DCE.

	DTE	DCE
Pin 2:	RD	TD
Pin 3:	TD	RD

RD: Received Data (digital input)

TD: Transmitted Data (digital output)

INFO: UMX-OPT-TX150R is DCE unit according to its pin-out.

Different type of serial cables must be used between different serial devices.

	DTE	DCE
DTE	Null-modem	TD
DCE	Straight	Null-modem*

* In general contact DCE with DCE by tail-circuit serial cable.

2.3.2. Types of Serial Cables

Straight Serial Cable

Straight pin-outs both ends.

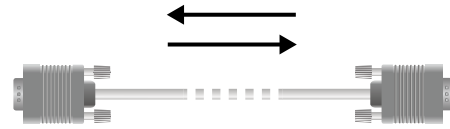

Null-modem Serial Cable

Straight pin-out at the one end and cross pin-out at the other end (interchange lines of TX and RX). For the detailed RS-232 connector pinout see [RS-232 Port](#) section.

Serial cables between devices may have male or female plugs and their type may be straight or null-modem in usual.

ATTENTION! The cable type does not depend on the plug type.

Connection Diagram - Examples

The following cases are Examples. Devices may have different receptacles and pinouts.

Extending RS-232 between Controller System (DTE) and Projector (DCE)

Connect straight serial cable between controller system (DTE) and the transmitter (DCE) and straight serial cable between receiver (DTE) and projector (DCE).

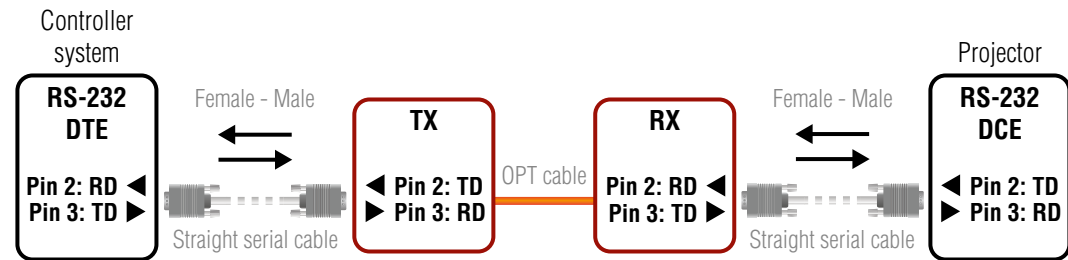

RS-232 connection Example between a controller system and a projector

Extending RS-232 between Computer (DTE) and Computer (DTE)

Connect straight serial cable between controller system (DTE) and the transmitter (DCE) and null-modem serial cable between receiver (DTE) and computer (DTE).

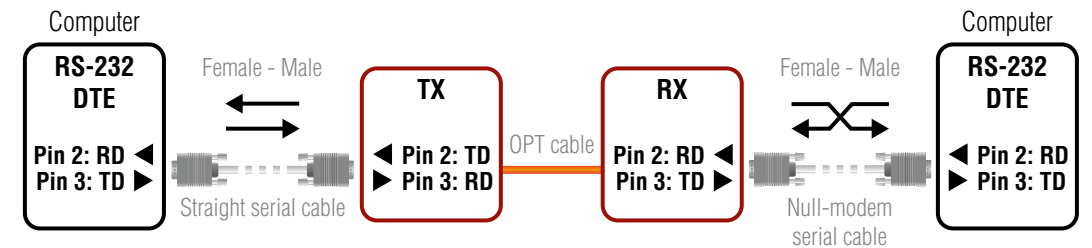

RS-232 connection Example between two computers

2.3.3. Connecting Serial Devices

Extender units can be UMX-OPT-TX150R and any compatible Lightware fiber optical receiver device. For more information see the table of [Compatible Devices](#).

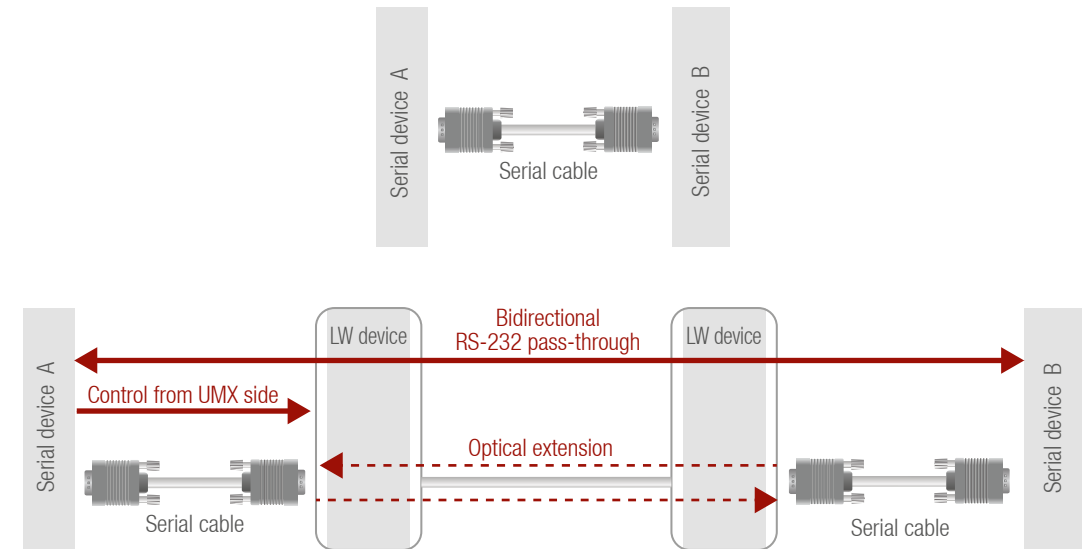

If cable's plug and device's receptacle do not match get a suitable cable or use a gender changer.

3

Product Overview

The following sections are about the physical structure of the device, input/output ports and connectors:

- ▶ [UMX-OPT-TX150R - FRONT VIEW](#)
- ▶ [UMX-OPT-TX150R - REAR VIEW](#)
- ▶ [ELECTRICAL CONNECTORS](#)
- ▶ [PORT DIAGRAM](#)

3.1. UMX-OPT-TX150R - Front View



- | | |
|---|--|
| <p>1 DVI-I IN DVI-I connector for connecting the video source to the transmitter via DVI cable (DVI-DVI or DVI-HDMI) or VGA cable (with VGA-to-DVI adapter). For more information see the DVI-I Input section.</p> | <p>6 Status LEDs The LEDs give feedback about state of the unit and the video and audio signals. For more information about names and meanings of the Status LEDs see Front Panel LEDs section.</p> |
| <p>2 VGA IN D-sub connector for analog video signal. For more details see VGA Input section.</p> | <p>7 VIDEO SELECT Button for switching between video inputs (DVI-D / DVI-A / VGA / HDMI / Autoselect) is available with the VIDEO select button. For more information see in Video Input Selection section.</p> |
| <p>3 AUDIO 1 -2 IN 3.5 mm jack connector for unbalanced analog stereo audio input signal with right and left channel. For more information see Analog Audio Input section.</p> | <p>8 AUDIO SELECT Button for switching between audio inputs (DVI-D / Audio 1 / Audio 2 / HDMI / S/PDIF) is available with the AUDIO select button. For more information see in Audio Input Selection section.</p> |
| <p>4 HDMI IN HDMI connector for DVI video or HDMI video and audio. For more details see the HDMI Input section.</p> | |
| <p>5 S/PDIF Input RCA jack connector with S/PDIF digital audio signal. For more information see S/PDIF Input section.</p> | |

3.2. UMX-OPT-TX150R - Rear View

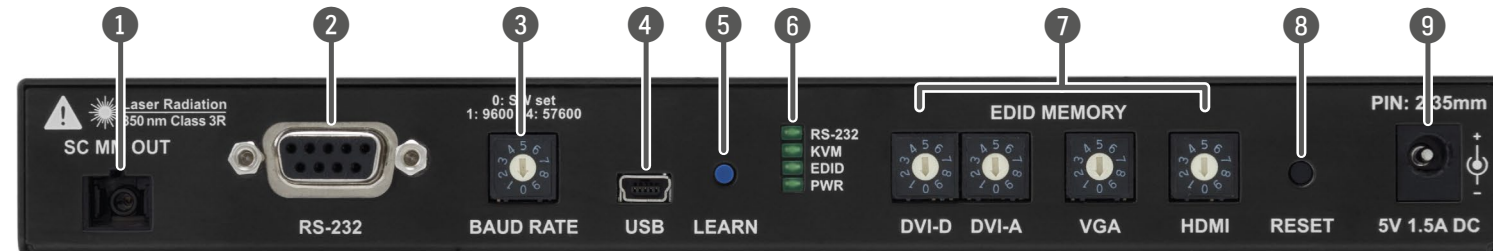

- | | | | |
|--|---|--|--|
| <p>1 SC Fiber Output</p> <p>2 RS-232 Port</p> <p>3 BAUD RATE Rotary Switch</p> <p>4 USB Port</p> | <p>Connect a 50/125 multimode fiber optical cable (OM4 is recommended) between the SC MM OUT of the transmitter unit and the SC MM IN of the receiver unit. (e.g. HDMI-3D-OPT-RX100RA or a Lightware Hybrid Matrix equipped with fiber optical input cards). For more information see Fiber Optical Output section.</p> <p>9-pole D-sub female connector for standard RS-232 port. Connect a serial cable between the transmitter unit and the serial device. RS-232 pass-through, third party control and Advanced EDID management are available via the RS-232 interface. For more information read RS-232 Port and Connection of Serial Devices chapters.</p> <p>The rotary switch selects one of 5 speeds of the serial communication (#1 .. #4) or the Software Control mode (#0). The #8 and #9 states are used for special functions.</p> <p>USB mini B-type connector for standard USB port. Connect a USB A – Mini USB B cable between the transmitter unit and the computer. Advanced EDID Management, control and firmware upgrades are available via the USB interface. For more information see USB Connector section.</p> | <p>5 LEARN Button</p> <p>6 Status LEDs</p> <p>7 EDID MEMORY Rotary Switch</p> <p>8 RESET Button</p> <p>9 DC 5V In</p> | <p>Stores the EDID of the display device attached to receiver device's video output in the selected memory address between #6 .. #9 on the selected input port. To learn the EDID, select the desired input and an appropriate address with the rotary switches and press and hold the Learn button for two seconds. For more details about Lean button see EDID Learning section.</p> <p>The LEDs give feedback about state of the unit and the video and audio signals. For more information about names and meanings of the Status LEDs see Front Panel LEDs.</p> <p>The rotary switch selects one of 10 addresses on every input port. EDID memories #1..#5 contain factory presets and #6..#9 are user programmable. Address #0 enable dynamic EDID emulation which copies EDID from receiver device's video output. For more information see EDID Memory Structure section.</p> <p>Hardware reset button. It resets the whole device, however saved settings and EDIDs will be preserved. This is the same as disconnecting from power source, and reconnect again.</p> <p>Connect the output of the supplied 5V DC power adaptor.</p> |
|--|---|--|--|

INFO: Use a flat head screwdriver to the rotary switches that fits into the actuator. Avoid the use of keys, coins, knives and other sharp objects because they might cause permanent damage to the rotary switches.

3.3. Electrical Connectors

3.3.1. DVI-I Input

The transmitter unit provides standard 29-pole DVI-I connectors for DVI-D (digital) or DVI-A (analog) inputs. This way, users can plug in any DVI connector, but keep in mind that the transmitter unit accepts single link DVI, HDMI or analog (such as VGA or RGBHV) signals on the DVI input.



INFO: Always use high quality DVI cable for connecting DVI devices.

3.3.2. VGA Input

The switcher provides a standard 15-pole D-SUB female connector for connecting VGA devices. Always use high-quality VGA cable for connect the source; using a VGA cable where all the pins are wired (including the DDC channel's wires) is highly recommended.

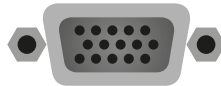

3.3.3. HDMI Input

UMX-OPT-TX150R provides standard 19 pole HDMI connectors for input. Always use high quality HDMI cable for connecting sources.



3.3.4. Fiber Optical Output

The transmitter has multimode SC fiber optical input connector.



INFO: Fiber optic cables can be easily damaged if they are improperly handled or installed. Handle the optical cables with care to avoid damage.

WARNING! Avoid exposure to beam! Direct intrabeam viewing normally hazardous.

3.3.5. Analog Audio Input

Unbalanced analog audio 1 and audio 2 can be connected to the device with TRS (Tip, Ring, and Sleeve) connectors. They are also known as (3,5 mm or approx. 1/8") audio jack, phone jack, phone plug, and mini-jack plug.

TRS connector pin assignment	
Pin nr.	Signal
1 Tip	Right channel
2 Ring	Left channel
3 Sleeve	Ground



3.3.6. S/PDIF Input

UMX-OPT-TX150R has standard RCA receptacles for digital coaxial audio input.



ATTENTION! Plugs and sockets on consumer equipment are conventionally color-coded by CEA/CEDIA- 863-B (ANSI) to aid correct connections. According to the standard Lightware uses orange colored RCA connectors for S/PDIF signals.

3.3.7. RS-232 Port

UMX-OPT-TX150R has RS-232 pass-through function or can be remote controlled through industry standard 9 pole D-SUB female connector. The extender uses RS-232 port.



D-sub connector pin assignment for standard RS-232	
Pin nr.	RS-232
1	NC - non connected
2	TX data transmit (output)
3	RX data receive (input)
4	DTR (Internally connected to Pin 6)
5	GND signal ground (shield)
6	DSR (Internally connected to Pin 4)
7	RTS (Internally connected to Pin 8)
8	CTS (Internally connected to Pin 7)
9	NC - non connected

3.3.8. USB Connector

UMX-OPT-TX150R has standard Mini USB Type B receptacle.



3.3.9. DC 5V Connection

Do not forget to turn the plug clockwise direction after connecting the power adaptor.

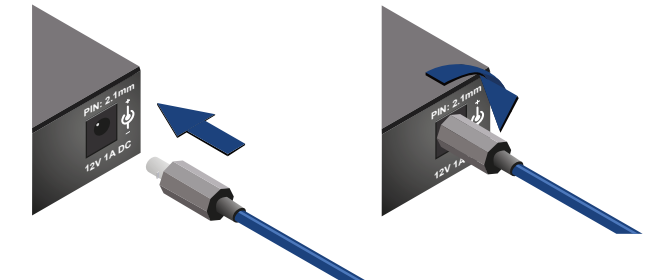

WARNING! Always use the supplied 5V power adaptor. Warranty is void if damage occurs due to use of a different power source.

3.4. Port Diagram

The following figure describes the port diagram of the UMX-OPT-TX150R.

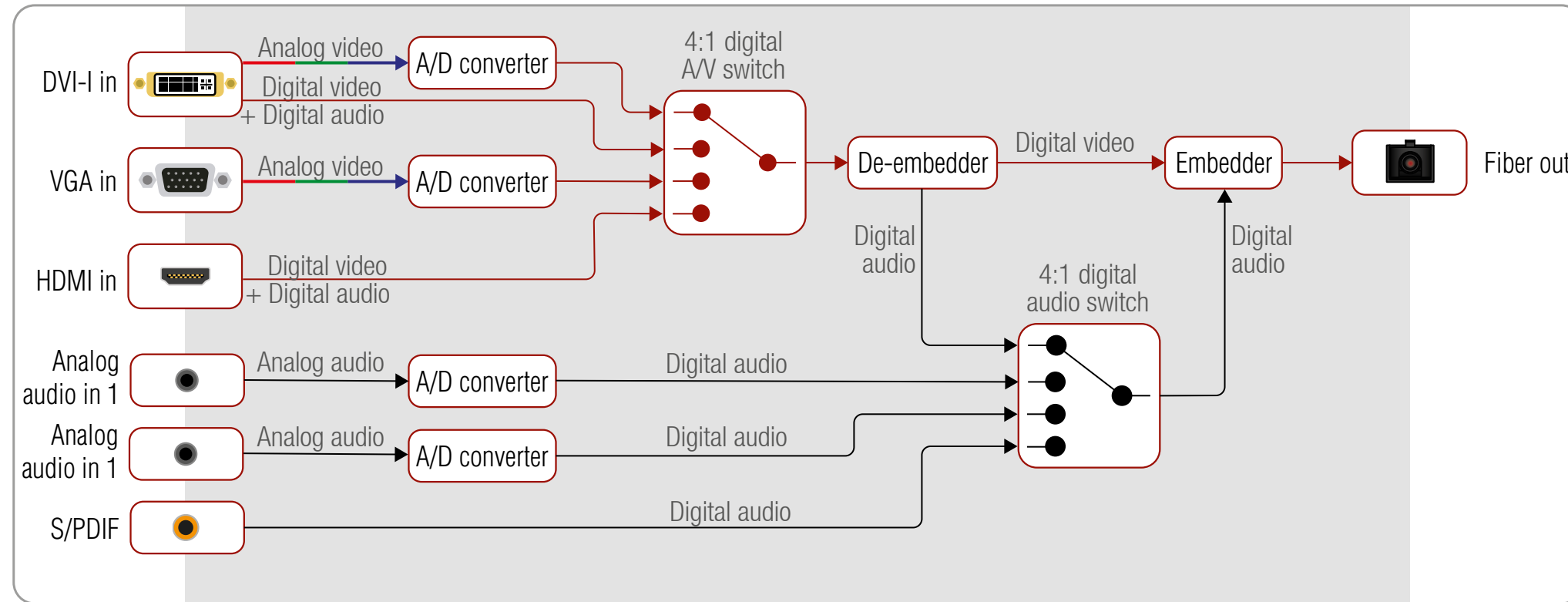

4

Operation of UMX-OPT-TX150R

This chapter is about the powering and operating of the device describing the functions which are available by the front/rear controls:

- ▶ BOOT UP OF UMX-OPT-TX150R
- ▶ FRONT PANEL LEDS
- ▶ REAR PANEL LEDS
- ▶ INPUT SELECTION
- ▶ VIDEO AUTOSELECT MODE
- ▶ AUDIO AUTOSELECT MODE
- ▶ EDID MANAGEMENT
- ▶ HDCP MANAGEMENT
- ▶ RELOAD FACTORY DEFAULTS
- ▶ SERVICE MENU
- ▶ REMOTE OPERATION

4.1. Boot up of UMX-OPT-TX150R

WARNING! When building an electronic system, make sure that all of the devices are powered down before connecting them. Powered on devices may have dangerous voltage levels that can damage sensitive electronic circuits.

After all the other connections in the system are complete, connect the output of the 5V Power Adaptor to the UMX-OPT-TX150R.

The special locking DC plug provides safe connection. Plug the connector into the 5V 1A DC IN receptacle and twist 90° clockwise to lock it. Plug the adaptor into the electric outlet. The unit is immediately powered ON.

4.1.1. Firmware Indication

After being powered on, the UMX-OPT-TX150R lights up all LEDs from top to bottom, than displays its firmware version using the three upper LEDs of the front panel VIDEO LED bar. The top LED (DVI-D) means the first number of the firmware version, actually this is the main version. From the top the second (DVI-A) and the third (VGA) LEDs mean the second and the third number of the firmware version, actually these are the subversions.

Example of the firmware version of 1.0.1.

The following Example shows this process for a firmware version of 1.0.1.

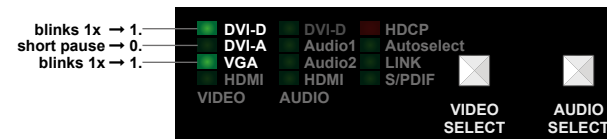

The top LED (DVI-D) blinks once → Short pause → The second LED (DVI-A) does not blink, this means the number 0 → Short pause → The third LED (VGA) blinks once → Short pause → The normal function of the LED is in effect.

After indicating the firmware version, UMX-OPT-TX150R checks the video output: reads the EDID if there is a Hot Plug signal and authenticates devices in case of HDCP encryption. This procedure takes approximately 5 seconds.

UMX-OPT-TX150R stores the video and audio crosspoint state in a non-volatile memory and after booting it starts with it.

After the UMX-OPT-TX150R is initialized, the attached source(s), receiver pair and monitor(s) can be powered on.

INFO: If none of the LEDs light up upon power-up, the unit is most likely damaged and further use is not advised. Please contact support@lightware.eu.

4.2. Front Panel LEDs

VIDEO Status LEDs (DVI-D, DVI-A, VGA, HDMI) is

- **ON** when the video input port is selected and there is a valid video signal on it.
- **BLINKING** when the video input port is selected and there is no valid video signal on it.
- **OFF** when the video input port is NOT selected. Another port is active or there was a disconnect command.



AUDIO Status LED (DVI-D, Audio 1, Audio 2, HDMI, S/PDIF) is

- **ON** when the audio input port is selected.
- **OFF** when the audio input port is NOT selected. Another port is active or there was a disconnect command.

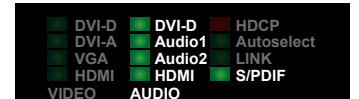

INFO: When all the front panel LEDs are blinking, they refers to the undefined baud rate settings (baud rotary switch is set from #5 to #9).



HDCP LED is

- **ON** when the HDCP setting of the output video signal is Always.
- **OFF** when the HDCP setting of the output video signal is AUTO.



Autoselect LED is

- **ON** when the autoselect mode is selected and a valid video signal is found.
- **BLINKING** when the autoselect mode is selected and video signal searching is in progress.
- **OFF** when autoselect mode is not selected and video input port can be chosen manually.



LINK LED is

- **ON** when the TX and the RX (or OPT-IB) are connected to each other via the optical cable and they can communicate.
- **OFF** when the TX and RX (or OPT-IB) are not connected or they CANNOT communicate.

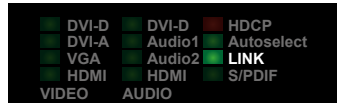

4.3. Rear Panel LEDs

RS-232 LED is

- **ON** when the RS-232 is in Control mode.
- **OFF** when the RS-232 is in Pass mode.



KVM LED is

- always **OFF** in this firmware version.

EDID LED is

- **ON** when there is a valid EDID on the currently active input port.
- **BLINKING FAST** continuously when there is an invalid EDID on the currently active input port.
- **BLINKS FAST THREE TIMES** when EDID learning was unsuccessful.
- **BLINKS SLOW THREE TIMES** when EDID learning was successful.



PWR LED is

- **ON** when the transmitter unit is powered with 5V DC and ready to use.
- **BLINKING** when the transmitter unit is powered but an error occurred.
- **OFF** when the transmitter unit is NOT powered or out of order.



4.4. Input Selection

Video and Audio input can be chosen by:

- **Video** and **Audio Select** button on the front panel (see [UMX-OPT-TX150R - Front View](#) section).
- Autoselect mode: ([Video Autoselect Mode](#) and [Audio Autoselect Mode](#).)
- **Software Control** – [Lightware Device Controller](#) software
- Protocol command ([Switch One Input to One Output](#) or [View All Connections on the Output](#))

4.4.1. Video Input Selection

The order of the video selection is shown below. After the **Video Select** button is pushed, the next video input will be chosen. The corresponding LED lights up.

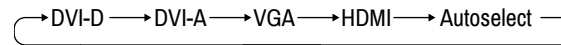

4.4.2. Audio Input Selection

The order of the audio selection depends on the selected video input. The available audio inputs are shown below. After the **Audio Select** button is pushed, the next input will be chosen. The corresponding LED lights up.

In case of analog video inputs (DVI-A and VGA) any audio input can be selected. After the **Audio Select** button was pushed, the next audio input will be chosen. The corresponding LED lights up.

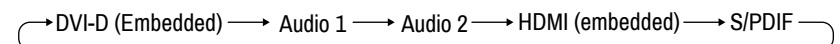

In case of the digital video inputs (DVI-D and HDMI) the embedded audio input of the selected video input, the analog audio 1, analog audio 2 inputs and the S/PDIF audio can be selected.

It means that analog audio input 1, analog audio input 2, HDMI embedded and S/PDIF audio inputs can be used for HDMI video input.

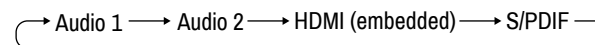

The DVI-D embedded audio, analog audio input 1, analog audio input 2 and S/PDIF audio inputs can be used for DVI-D video input.



4.5. Video Autoselect Mode

The Autoselect function means UMX-OPT-TX150R can recognize the incoming valid video on all the input ports and can choose one automatically, without user intervention. Autoselect searching starts after an event. It can be the stepping into Autoselect mode, plugging or unplugging a video or audio cable or appearing or disappearing a valid video signal.

Video Input in Autoselect Mode

ATTENTION! DVI-D, VGA and HDMI video inputs are available for video autoselect. DVI-A input can be chosen manually only.

The video Autoselect mode can work in three ways:

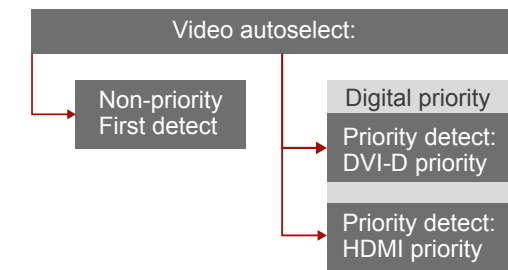

4.5.1. Non-Priority (First Detect)

The device will select that port, where a valid video signal appears at first.

If the selected input was unplugged or the valid video signal was disappeared, the searching process starts again from the DVI-D input. Until there is a valid video signal on the selected port, the searching process does not start again.

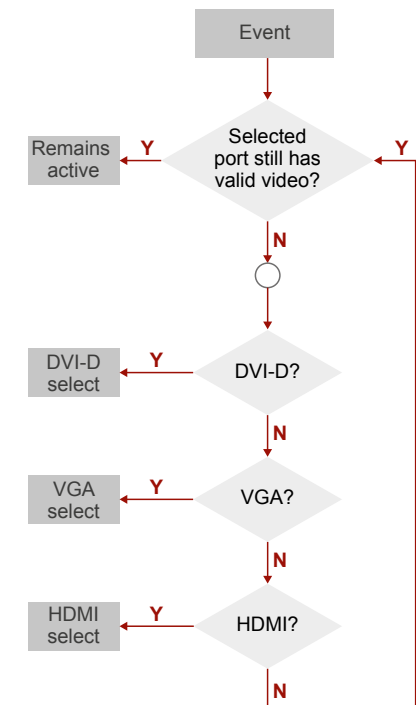

4.5.2. HDMI Digital Priority

The device will select the HDMI port, if there is a valid video sign in it.

If one of the input ports (e.g. VGA) was selected and there is a valid video signal on it and a valid video signal was appeared on the HDMI input port – by connecting or powering on a video source, the searching process starts again with checking the video signal on the HDMI input.

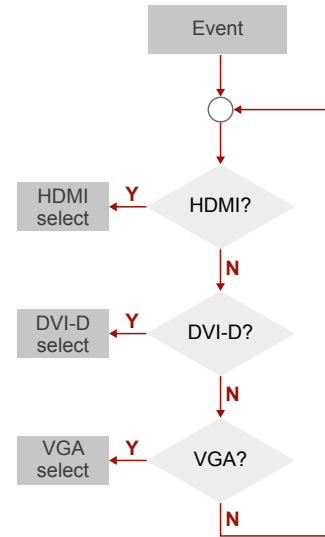

4.5.3. DVI-D Digital Priority

The device will select the DVI-D port, if there is a valid video sign in it.

If one of the input ports (e.g. VGA) was selected and a valid video signal was appeared on the DVI-D input port – by connecting or powering on a video source, the searching process starts again with checking the video signal on the DVI-D input.

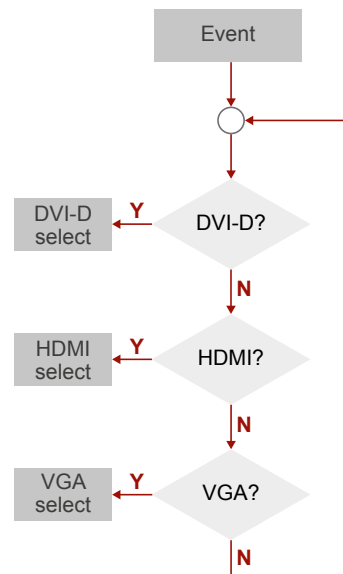

User can toggle between the three video Autoselect priority modes with the Lightware Device Controller software (see [Autoselect Settings](#) chapter), or [Service Menu](#).

4.6. Audio Autoselect Mode

The Autoselect function means UMX-OPT-TX150R can recognize the incoming valid video and audio signals on all the input ports and can choose one automatically, without user intervention. Autoselect searching starts after an event. It can be the stepping into Autoselect mode, plugging or unplugging a video or audio cable or appearing or disappearing a valid video or audio signal.

Audio inputs, which are available for audio Autoselect mode:

- DVI-D or HDMI embedded (either of them, depends on the result of the video autoselect)
- S/PDIF and
- Analog audio 2

Audio input, which can be chosen manually only:

- Analog audio 1

The audio Autoselect mode can work in ten ways:

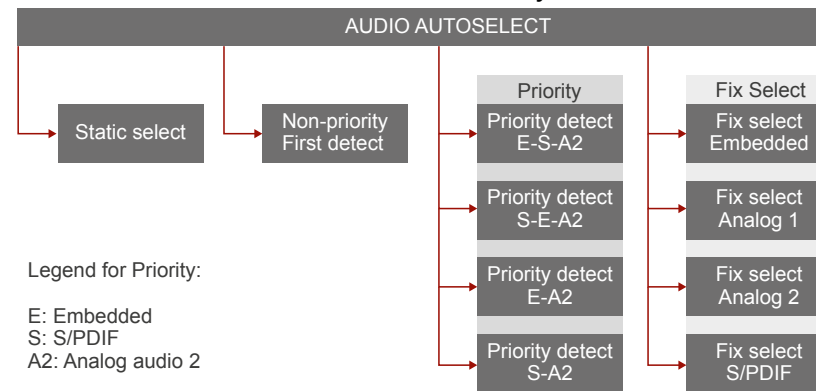

User can toggle between the ten audio Autoselect priority modes with the Lightware Device Controller software (see details in [Autoselect Settings](#) chapter), or with the [Service Menu](#).

4.6.1. Static Select

In this mode all audio inputs are assigned to the video inputs statically:

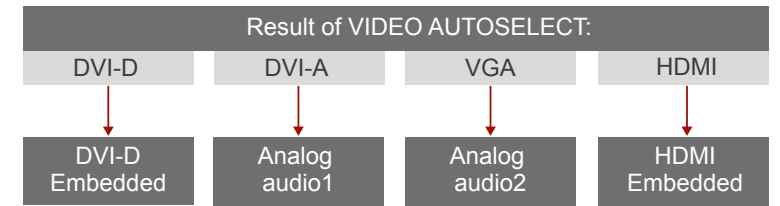

4.6.2. Non-Priority (First Detect)

After the video Autoselect the device checks the embedded audio input.

DVI-D embedded audio input to the DVI-D video input or HDMI embedded audio input to the HDMI video input.

A valid embedded audio signal it will be selected if it exists.

If there is no valid embedded audio signal the device checks the audio inputs. First, it checks S/PDIF, then Analog audio 2 port.

In case of an event (any audio is plugged or unplugged) the selected port remains the active input port if there is a valid audio signal on it.

If the audio signal disappears on the selected port the searching process starts again.

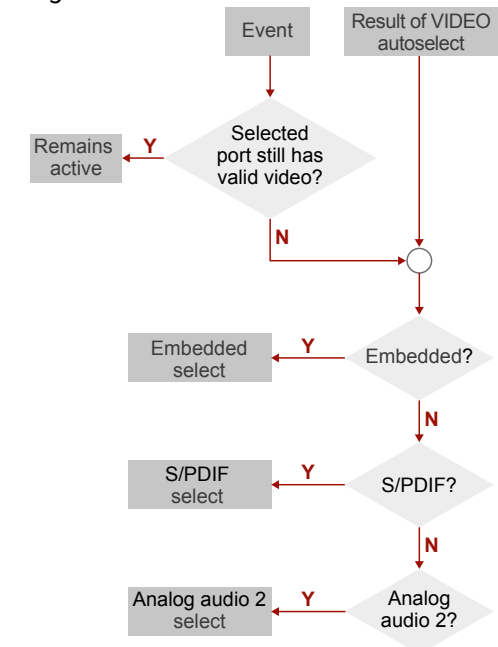

4.6.3. Priority Detect

In priority detect mode, the result of the video autoselect declares the embedded audio input.

If the selected video port is the DVI-D, the embedded audio input will be DVI-D also. If the selected video port is the HDMI, the embedded audio input will be HDMI.

Embedded, S/PDIF, Analog Audio 2

After the video Autoselect the device checks the audio inputs in a pre-defined order:

First, it checks embedded audio, then S/PDIF and final the Analog audio 2 port.

- If there is a valid audio signal, it will be selected.
- If the device can not find any audio signal, audio 2 input will be selected.

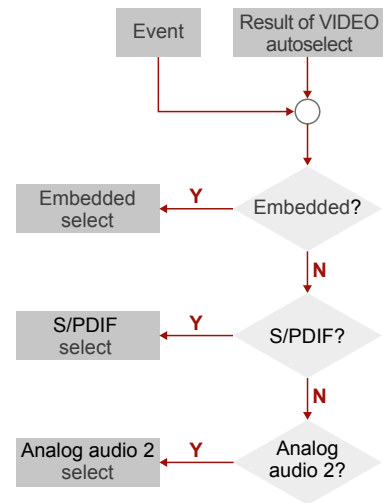

INFO: Any audio event occurs a new searching from the embedded input port.

INFO: The selected audio input will be active until the new result of video Autoselect or a new audio event.

S/PDIF, Embedded, Analog Audio 2

After the video Autoselect the device checks the audio inputs in a pre-defined order:

First, it checks S/PDIF, then embedded audio and final the analog audio 2 port.

- If there is a valid embedded audio signal it will be selected.
- If there is no valid embedded audio signal on the embedded input port the device selects the analog audio 2 input, even if there is no audio signal on this input.

INFO: Any audio event occurs a new searching from the S/PDIF input port.

INFO: The selected audio input will be active until a new result of video Autoselect, an audio event.

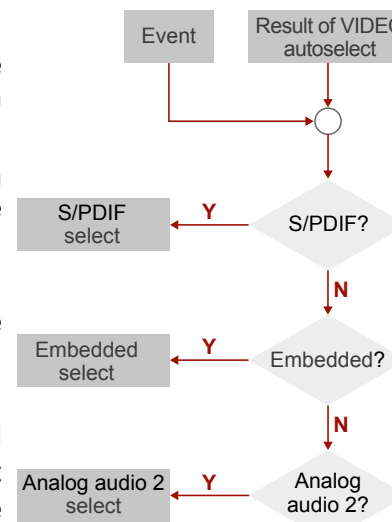

Embedded, Analog Audio 2

After the video Autoselect the device checks the embedded audio input.

- If there is a valid embedded audio signal it will be selected.
- If there is no valid embedded audio signal the device selects the analog audio 2 input, even if there is no audio signal on this input.

INFO: Any audio event occurs a new searching from the embedded input port.

INFO: The selected audio input will be active until a new result of video Autoselect, an audio event or the device exits from the Autoselect mode.

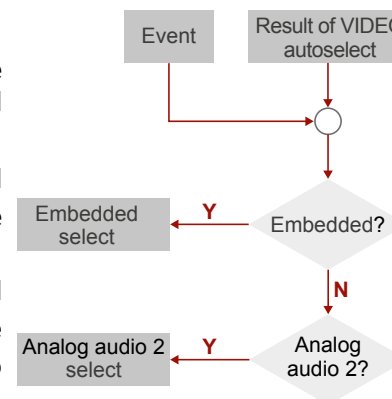

S/PDIF, Analog Audio 2

After the video Autoselect the device checks the S/PDIF audio input.

- If there is a valid S/PDIF audio signal on the S/PDIF audio input it will be selected.
- If there is no valid audio signal on the S/PDIF audio input port the device selects the analog audio 2 input, even if there is no audio signal on this input.

INFO: Any audio event occurs a new searching from the S/PDIF input port.

INFO: The selected audio input will be active until a new result of video Autoselect, an audio event.

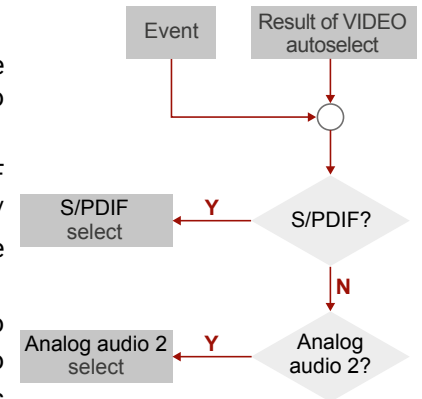

4.6.4. Fix Selection

Fix selection mode is independent of the result of video autoselect or the active audio signal.

All audio inputs can be chosen: Embedded, Analog Audio 1, Analog Audio 2, S/PDIF.

The selected audio input is active until another Audiopriority setting or the device exits from the Autoselect mode.

4.7. EDID Management

About EDID Memory

EDID memory is non-volatile and consists of four blocks, each for different purpose. These blocks are:

- Factory preset EDIDs
- User saved EDIDs
- Dynamic EDID (EDID of last connected sink on the DDC output port)
- Emulated EDIDs (EDID currently emulated on a specific input port)

This manual refers to the EDIDs in two ways. Using, selecting EDIDs with Lightware Device Controller (LDC) software or with Rotary switches.

4.7.1. EDID Memory Structure

EDIDs Are Referred with Lightware Device Controller

In the first case EDID is mentioned with the Lightware Device Controller software or the protocol commands.

Factory Preset EDIDs (F01 .. F20):

- F01 .. F05 DVI-D Factory Preset EDIDs
- F06 .. F10 DVI-A Factory Preset EDIDs
- F11 .. F15 VGA Factory Preset EDIDs
- F16 .. F20 HDMI Factory Preset EDIDs

INFO: The factory EDIDs (Fxx) are factory preprogrammed and cannot be modified. These are the most commonly used resolutions.

User programmable memories (U01 .. U16):

- U01 .. U04 User programmable DVI-D memories
- U05 .. U08 User programmable DVI-A memories
- U09 .. U12 User programmable VGA memories
- U13 .. U16 User programmable HDMI memories

Last attached monitor’s EDID: (D01):

- D01 Last attached monitor’s EDID on the output

INFO: The attached monitor’s EDID is the Lightware Universal EDID by factory default.

Emulated EDIDs (E01 .. E04):

- E01Emulated EDIDs on the DVI-D input
- E02 Emulated EDIDs on the DVI-A input
- E03 Emulated EDIDs on the VGA input
- E04 Emulated EDIDs on the HDMI input

INFO: UMX-OPT-TX150R can handle both 128 Byte EDID and 256 Byte extended EDID structures.

EDIDs Are Referred with Rotary Switches

In the second case EDID is mentioned with the rear panel rotary switches. EDIDs are numbered from 0 on each rotary, and they can be referred with hash symbol, and the number of the desired EDID. This way #6 on the DVD-D rotary refers to the first user preset EDID (U01), and #0 refers to the display device’s EDID (called Dynamic or Last attached monitor’s EDID) on the output (on the DDC output).

ATTENTION! Emulated EDIDs can be switched with the rotary switches only.

The Assigning Table

To help understand the EDID memory structure. See the table of [Factory EDID List](#). It shows all the EDIDs, their short descriptions and their references.

All EDIDs (including factory presets; user programmable memories and EDID at SC MM output) can be switched and emulated at any of the inputs.

Example State of the Rotary Switches

The rotary switches select the EDIDs highlighted gray in the tables below.

The rotary switches have the following state:

 DVI-D Rotary is in #2 state, it means Factory EDID (DVI) 1024x768@60 is the selected EDID on the DVI-D input port.

DVI-D EDID Rotary		
#0	Copy from SC MM OUT (Dynamic EDID)	D01
#1	Factory EDID Universal HDMI (default)	F01
#2	Factory EDID (DVI) 1024x768@60	F02
#3	Factory EDID (HDMI) 1280x720p@60	F03
#4	Factory EDID (HDMI) 1920x1080p@60	F04
#5	Factory EDID (DVI) 1920x1200@60	F05
#6	User EDID (def.: Univ. HDMI EDID)	U01
#7	User EDID (def.: Univ. HDMI EDID)	U02
#8	User EDID (def.: Univ. HDMI EDID)	U03
#9	User EDID (def.: Univ. HDMI EDID)	U04



DVI-A Rotary is in #5 state, it means Factory EDID (Analog) 1920x1200@60 is the selected EDID on the DVI-A input port.

DVI-A EDID Rotary		
#0	Copy from SC MM OUT (Dynamic EDID)	D01
#1	Factory EDID Universal Analog (default)	F06
#2	Factory EDID (Analog) 1024x768@60	F07
#3	Factory EDID (Analog) 1280x720@60	F08
#4	Factory EDID (Analog) 1920x1080@60	F09
#5	Factory EDID (Analog) 1920x1200@60	F10
#6	User EDID (def.: Univ. Analog EDID)	U05
#7	User EDID (def.: Univ. Analog EDID)	U06
#8	User EDID (def.: Univ. Analog EDID)	U07
#9	User EDID (def.: Univ. Analog EDID)	U08



VGA Rotary is in #0 state, it means Dynamic EDID is the selected EDID on the VGA input port. (The EDID will be copied from SC MM OUT).

VGA EDID Rotary		
#0	Copy from SC MM OUT (Dynamic EDID)	D01
#1	Factory EDID Universal Analog (default)	F11
#2	Factory EDID (Analog) 1024x768@60	F12
#3	Factory EDID (Analog) 1280x720@60	F13
#4	Factory EDID (Analog) 1920x1080@60	F14
#5	Factory EDID (Analog) 1920x1200@60	F15
#6	User EDID (def.: Univ. Analog EDID)	U09
#7	User EDID (def.: Univ. Analog EDID)	U10
#8	User EDID (def.: Univ. Analog EDID)	U11
#9	User EDID (def.: Univ. Analog EDID)	U12



HDMI Rotary is in #8 state, it means the 3rd User EDID is the selected EDID on the HDMI input port.

HDMI EDID Rotary		
#0	Copy from SC MM OUT (Dynamic EDID)	D01
#1	Factory EDID Universal HDMI (default)	F16
#2	Factory EDID (DVI)	F17
#3	Factory EDID (HDMI)	F18
#4	Factory EDID (HDMI)	F19
#5	Factory EDID (DVI)	F20
#6	User EDID (def.: Univ. HDMI EDID)	U13
#7	User EDID (def.: Univ. HDMI EDID)	U14
#8	User EDID (def.: Univ. HDMI EDID)	U15
#9	User EDID (def.: Univ. HDMI EDID)	U16

Switching the EDID with a Rotary Switch

Use a screwdriver to change the memory address on the rear side of the UMX-OPT-TX150R. After either one of the rotary switches has been rotated, the unit waits approximately 2 seconds before the selected EDID becomes active.

INFO: After every EDID change, UMX-OPT-TX150R toggles the HOT PLUG signal for approx. 1 second. Some graphic cards or DVD players do not sense the HOT PLUG signal, and even if EDID has been changed, the set resolution is not affected. In this case the source device must be restarted, or powered OFF and ON again.

ATTENTION! Switching EDID for any inputs is available only with rotary switches. (Switching with Lightware Device Controller Software or protocol command is not available.)

4.7.2. Deleting the EDID

Deleting EDID is available only with Lightware Device Controller Software. Only user EDIDs can be deleted. Deleting means the factory EDID (Universal HDMI or Analog EDID) will be loaded into the desired user EDID memory.

4.7.3. EDID Types

Most of the factory preset EDIDs include only one resolution. This is to force the connected source to give a signal with the needed resolution. However there are Universal EDIDs as well which allow many resolutions.

The factory EDIDs are divided into groups regarding their type. Some EDIDs are supporting DVI only, some support HDMI, and some are for analog VGA signals.

- Analog EDIDs can be used for VGA (RGBHV) input port.
- DVI EDIDs does not support embedded audio.
- HDMI EDIDs support embedded audio. These EDIDs – include Universal HDMI EDID - indicate that any audio Format is accepted (PCM, Dolby, DTS, etc.).

INFO: Analog and HDMI user EDIDs are the Universal Analog and HDMI EDIDs in factory defaults.

Factory Preset EDID List

Lightware factory pre-loaded EDIDs are specially provided to force graphic cards to output only the exact pixel resolution and refresh rate.

HDMI and VGA universal EDIDs (#1 on both rotary switches) allow multiple resolutions including all common VESA defined resolutions. In addition, HDMI universal EDID also features audio support. The use of universal EDID is recommended for fast and easy system setup.

Mem.	Resolution	Type	Audio support		Deep color support		
			PCM	Other	24 bit	30 bit	36 bit
F01	Universal_HDMI_DC	HDMI	✓	✓	✓	-	✓
F02	1024 x 768 @ 60.0 Hz	DVI	-	-	-	-	-
F03	1280 x 720 @ 60.0 Hz	HDMI	✓	-	✓	-	-
F04	1920 x 1080 @ 60.0 Hz	HDMI	✓	-	✓	-	-
F05	1920 x 1200 @ 59.55 Hz	DVI	-	-	-	-	-
F06	Universal_Analog	Analog	-	-	-	-	-
F07	1024 x 768 @ 60.0 Hz	Analog	-	-	-	-	-
F08	1280 x 720 @ 60.0 Hz	Analog	-	-	-	-	-
F09	1920 x 1080 @ 60.0 Hz	Analog	-	-	-	-	-
F10	1920 x 1200 @ 59.55 Hz	Analog	-	-	-	-	-
F11	Universal_Analog	Analog	-	-	-	-	-
F12	1024 x 768 @ 60.0 Hz	Analog	-	-	-	-	-
F13	1280 x 720 @ 60.0 Hz	Analog	-	-	-	-	-
F14	1920 x 1080 @ 60.0 Hz	Analog	-	-	-	-	-
F15	1920 x 1200 @ 59.55 Hz	Analog	-	-	-	-	-
F16	Universal_HDMI_DC	HDMI	✓	✓	✓	-	✓
F17	1024 x 768 @ 60.0 Hz	DVI	-	-	-	-	-
F18	1280 x 720 @ 60.0 Hz	HDMI	✓	-	✓	-	-
F19	1920 x 1080 @ 60.0 Hz	HDMI	✓	-	✓	-	-
F20	1920 x 1200 @ 59.55 Hz	DVI	-	-	-	-	-

INFO: The F01..F20 EDIDs are factory preprogrammed and cannot be modified. These are the most commonly used resolutions.

4.7.4. EDID Learning

Learning the EDID function enables to store the EDID of the display which connected to the receiver in UMX-OPT-TX150R's memory.

The factory preset EDIDs cannot be changed by the user. Only addresses #6 .. #9 (on any rotary switches) are user programmable.

ATTENTION! EDID learning is only available from the active input to a user memory location which was selected by a rotary switch. EDID learning is not allowed in AUTOSELECT mode.

INFO: Before a digital EDID will be selected to an analog output port UMX-OPT-TX150R removes the digital descriptor from the EDID and selects it.

Step 1. Connect the sink device to the unit's output (for Example the receiver unit's HDMI OUT)

Step 2. Use a screwdriver to select an empty memory address. (for Example on a HDMI rotary set the #6)

Step 3. Push the **Learn** button on the front side of the device and hold it down for approximately 3 seconds.

Step 4. If the EDID storing was successful on the active port, the EDID LED blinks 3 times in 3 seconds slowly then they return to their original function. EDIDs are stored in a multiple programmable non-volatile memory.

If the storing was unsuccessful on the active port, the EDID LED blinks 3 times in 1 second quickly then they return to their original function.

INFO: The last attached monitor's EDIDs are stored automatically, until a new monitor is attached to the output (or receiver's output). In case of powering the unit off, the last attached monitor's EDID remains in non-volatile memory.

4.7.5. EDID Switching

Use a screwdriver to change the memory address on the rear side of the UMX-OPT-TX150R.

After any of the rotary switches has been rotated, the unit waits approximately 2 seconds before the selected EDID becomes active.

The address #0 (on any rotary switches) has a special function. If a receiver is connected to the output, then its EDID is copied to the input connector. If no receiver is connected to the output then the EDID transmitted to the input connector is the EDID of the last connected monitor.

INFO: After every EDID change, UMX-OPT-TX150R toggles the HOT PLUG signal for approx. 1 second. Some graphic cards or DVD players do not sense the HOT PLUG signal, and even if EDID has been changed, the set resolution is not affected. In this case the source device must be restarted, or powered OFF and ON again.

ATTENTION! Switching EDID for any inputs is available only with rotary switches. (Switching with protocol command is not available, for more details about switching with Lightware Device Controller Software see [Changing Emulated EDID](#) section).

4.8. HDCP Management

The UMX-OPT-TX150R can work as a HDCP compliant device, or act as a non-HDCP compliant sink. The HDCP capability can be disabled or enabled on the digital video input ports (DVI-D, HDMI). This function helps to apply encryption only when it is mandatory.

Some video sources send encrypted signal when they are connected to a HDCP capable device even if the content is not protected. This way even the unprotected content cannot be displayed on non-HDCP displays if the signal travels through a HDCP compliant matrix or repeater.

However HDCP encryption is not required all the time (e.g. computer desktop image) some video cards still encrypt if they detect that the sink is HDCP capable.

Avoiding Unnecessary HDCP Encryption

If HDCP is disabled on any digital video input port, the connected source will detect that the sink is not HDCP capable, and turn off authentication. The source will not be able to communicate with any of the devices (displays, repeaters, etc.) that are connected to the receiver's output, therefore it could not see if they are HDCP capable or not.

This forces the source to send unprotected signal only. If HDCP capability is disabled on an input port, the connected source cannot send protected content to any display. If HDCP function is enabled on an input port and the source sends encrypted signal, the non-HDCP compliant devices cannot display the video.

INFO: In HDCP disable mode, protected content (i.e. Blu-ray disc) will not be displayed, thus maintaining the rules set by the HDCP standard.

To toggle the HDCP function on the desired input port, use Lightware Device Controller software ([HDCP Enable](#)) or turn the desired digital input's rotary switch to address #1, and press and hold the **Learn** button for approximately 5 seconds.

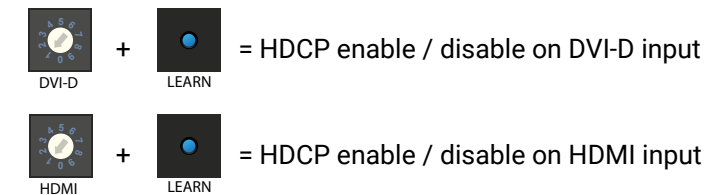

The status change appears on the front panel's LED tower. When the status changed the EDID LED blinks three times quickly.

HDCP Key Counter

HDCP key counter is a tool that counts and validates the number of keys that can be accepted by a source device when connected to an HDCP repeater.

HDCP key counting is available with protocol command. For more information, see [Count HDCP Keys](#) section.

4.9. Reload Factory Defaults

Factory default settings can be reloaded with the procedure below:

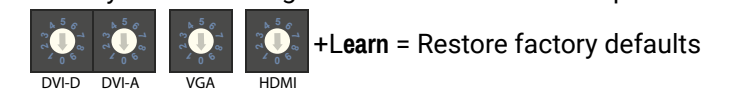

Turn all of the rotary switches to address #0, and press and hold the **Learn** button for approximately 10 seconds.

After restoring default values press the **Reset** button to reboot the device. This operation affects the crosspoint table and configuration, I/O settings and stored User and Dynamic EDIDs and the RS-232 mode.

This process can be induced by protocol command as well. For more information see [Reload Factory Defaults](#) section.

WARNING! User and Dynamic EDIDs will be cleared (refilled with Lightware Universal EDID) after reloading the factory defaults.

WARNING! Reloading factory defaults by rotary switches plus learn button AFFECTS the serial operation mode and the RS-232 baud rate options as well. The default operation mode is the PASS mode and the default baud rate is 57600 baud in the UMX-OPT-TX150R. If the previous serial settings differ from the default ones, please set up the necessary values after reboot with protocol commands. (See details about the protocol commands in [Set the RS-232 Operation Mode](#) section and the [Change RS-232 Baud Rate](#) section).

4.10. Service Menu

The service menu allows changing some main services (without using any controller software) which are not available directly with front or rear panel operation.

The menu contains functions (what device has e.g. Video priority mode, Output mode) as a menu items and every function have some (at least two) values can be set. There is no submenu.

INFO: The normal operation is suspended if the device enter the service menu. Video, audio and RS-232 transmission is stopped during the service menu. Signal transmission will be restored after a reboot.

4.10.1. Enter the Service Menu of UMX-OPT-TX150R

Step 1. Supply the unit with 5V DC

Step 2. Press and hold the **Reset** button.

Step 3. While pressing and holding the **Reset** button press and hold the **Video Select** button.

Step 4. Release the **Reset** button.

Step 5. Release the **Video Select** button.

INFO: Don't need to unplug video or fiber cables to enter the service menu.

4.10.2. Service Menu Display and Navigation

The service menu uses the device's LEDs to inform the user.

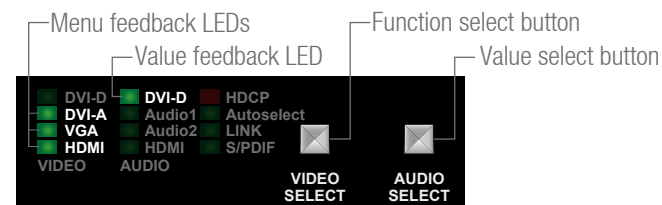

Menu Feedback LEDs

Some of the devices' LEDs (three or four LEDs in generally) show the number of the currently selected function (menu item) IN BINARY FORM. These LEDs are called **menu feedback LEDs**.

The **menu feedback LEDs** are the DVI-A, VGA and HDMI VIDEO LEDs in case of the UMX-OPT-TX150R.

The next table contains a detailed Example of a binary display.

Binary form by LEDs	Decimal form	Menu item
LED 1: DVI-D LED 2: DVI-A LED 3: HDMI	1st function	Output mode
LED 1: DVI-D LED 2: DVI-A LED 3: HDMI	2nd function	HDCP input mode for all inputs
LED 1: DVI-D LED 2: DVI-A LED 3: HDMI	3rd function	HDCP output mode
LED 1: DVI-D LED 2: DVI-A LED 3: HDMI	4th function	NoSyncScreen enable for all inputs
LED 1: DVI-D LED 2: DVI-A LED 3: HDMI	5th function	Video priority
LED 1: DVI-D LED 2: DVI-A LED 3: HDMI	6th function	Audio priority
LED 1: DVI-D LED 2: DVI-A LED 3: HDMI	7th function	Audio fix

Value Feedback LED

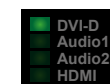

Audio DVI-D LED shows the number of the currently selected value of the selected menu item by its blinking number. It is called **value feedback LED**. If the selected menu item contains six values can be set the LED can be blinks from one to six according the number of the selected value. If the selected value is the 5th one the LED blinks 5 times. After a short break the LED starts blinking 5 times again.

The next table shows the modifiable values of all the menu items and the equivalent blinking numbers.

Decimal form	Menu item	Number of blinks on DVI-D audio LED with the available settings					
		1x	2x	3x	4x	5x	6x
1st function	Output mode	Auto	DVI	HDMI 24	n/a	n/a	n/a
2nd function	HDCP input mode for all inputs	Disable	Enable	n/a	n/a	n/a	n/a
3rd function	HDCP output mode	Auto	Always	n/a	n/a	n/a	n/a
4th function	NoSyncScreen enable for all inputs	Disable	Enable	n/a	n/a	n/a	n/a
5th function	Video priority	First detect	DVI-D priority	n/a	n/a	HDMI priority	n/a
6th function	Audio priority	Static select	First detect	Priority E - S - A2	Priority S - E - A2	Priority E - A2	Priority S - A2
7th function	Audio fix	Embedded	Analog 1	Analog 2	S/PDIF	n/a	n/a

WARNING! The values (enable / disable) of the HDCP input mode and the NoSyncScreen functions (in the highlighted rows) can be set for every input port separately during the normal operation. The service mode set the value FOR ALL THE INPUT PORTS. The value feedback LED shows enable value if the NoSyncScreen or the HDCP is enabled on ANY input port.

INFO: The audio priority modes use the following abbreviations: E Embedded, S – S/PDIF, A1 – Analog 1, A2 – Analog 2 audio input port. For the detailed explanation of the Autoselect mode see [Audio Autoselect Mode](#) chapter.

Navigation in the Service Menu

The VIDEO SELECT button is the **function select** button and the AUDIO SELECT button is the **value select** button in case of the UMX-OPT-TX150R.

After the entering the 1st menu item and the last saved value will be selected.

INFO: The functions and the settings in the service menu can be modified by Lightware Device Controller software or protocol commands, as well. The last saved values mean the last saving by any way, instead of the last saving by the service menu.

After every pressing of the **function select** button the next function will be selected. (The value feedback LED shows the corresponding last saved value.) The first menu item will be selected after the last one. After every pressing of the **value select** button the next value will be selected. The first value will be selected after the last one.

4.10.3. Saving in the Service Menu

The saving time is three seconds in case of the UMX-OPT-TX150R. In the service menu the device saves every value changing after three seconds automatically. If the device exits from service menu (because of a hardware reset) before 3 seconds after a value changing the last modification will be lost.

4.10.4. Exit from Service Menu

During the service menu the device is suspends its normal operation. The signal transmission and the communication (USB, RS-232 control and RS-232 pass-through) are out of work in this case. The only way to restore the normal operation is a hardware reset. It can be performed by pushing and releasing the Reset button on the rear side of the device or just plugging out then plugging in the power supply. The saved settings are stored in an external storage and the device keeps that after reboot.

4.11. Remote Operation

UMX-OPT-TX150R can be controlled through various interfaces remotely. This makes it possible to use functions that are not accessible via the front panel. Also, this helps system integrators and operators to control multiple devices in a big system through a single user interface.

4.11.1. Control Interfaces

Users can connect to the transmitter through

- USB
- Serial port (RS-232)

After establishing connection, there is no difference between connection types (except some rare cases, which are uniquely noted).

The available remote connections and the relating chapters are listed below.

User Interface	Connection type		Further Information
	USB port	RS-232 serial port	
Lightware Device Controller software	✓	✓	Software Control – Lightware Device Controller
Third-party control system	-	✓	LW2 Protocol Description

4.11.2. Multiple Simultaneous Connections

The transmitter allows simultaneous remote control over multiple interfaces. USB and Serial connections can be used at the same time.

4.11.3. RS-232 Operation Modes

Serial Port Settings

UMX-OPT-TX150R uses RS-232 communication port. The device uses standard RS-232 interface with the following default settings:

57600 Baud, 8 data bit, 1 stop bit, no parity

The serial port baud rate can be changed with the **Baud Rate** rotary (addresses #1 .. #4) on the rear panel ([UMX-OPT-TX150R - Rear View](#)) or remotely by protocol command in case of #0 **Baud Rate** rotary state (in [Change RS-232 Baud Rate](#) section).

There are two kinds of operations for the unit regarding the serial port: you can control the unit via USB and serial port or use the bidirectional

serial link through the fiber optical cable with a compatible fiber optical receiver.

Control Mode

In the first case the CPU in the transmitter can receive commands and send responses either to and from the own serial port or to and from the serial port on the receiver unit through the fiber optical cable.

Pass-Through Mode

In case of the second mode the serial connectors on the transmitter and on the receiver are linked together through the fiber optical cable

Changing the Working Mode

Step 1. Turn the Baud Rate rotary switch to address #8

Step 2. Press and hold the Learn button for approximately 3 seconds. (The addresses of EDID Memory rotary switches can be anything.)

Step 3. The current status can be seen on the rear panel LED tower. If the working mode is Pass-through the RS-232 LED is off. If the working mode is Control the RS-232 LED lights continuously.

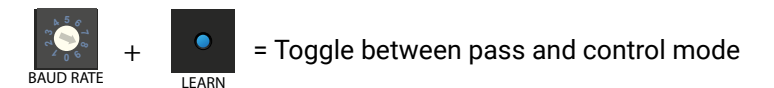

Changing the working mode can be done by protocol command (see details [Set the RS-232 Operation Mode](#) section).

INFO: UMX-OPT-TX150R stores the RS-232 working mode and starts the saved one after reboot.

ATTENTION! The RS-232 settings – baud rate is included – are valid for the Control and the Pass-through mode, as well. For Example if the baud rate was changed from 57600 to 9600 in Control mode the device sends commands only with 9600 baud rate in Pass-through mode, as well.

Speed of the Serial Communication

Baud rate can be set in two ways:

- Baud rate rotary is turned #0. In this case, the baud rate can be modified by protocol command. For details see [Change RS-232 Baud Rate](#) section.
- Baud rate can be also set on the rear panel by the baud rate rotary. The rotary should turn #1- #4 and it applies pre-defined baud rates. In this case, protocol commands have no effect on the speed of the serial communication.

UMX-OPT-TX150R uses some of the standard timings for the RS-232 control and pass-through mode. To work the bidirectional serial communication well between serial ending devices users must choose the proper baud rate on the transmitter units. Please read the serial devices' user's manual to find the appropriate baud rates. The best one is both devices' most common value.

If the communication speed ability of a serial device is unknown use the lowest (#1: 9600) value.

Available BAUD RATE rotary values:

Rotary switch position	BAUD rate
#0	Software set (57600 default)
#1	9600
#2	19200
#3	38400
#4	57600
#5	Not used
#6	Not used
#7	Not used
#8	RS232=Pass / Control
#9	KVM (under development)

INFO: When all the front panel LEDs are blinking, they refers to the undefined baud rate settings (baud rotary switch is set from #5 to #9).

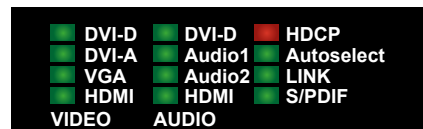

Detailed Example

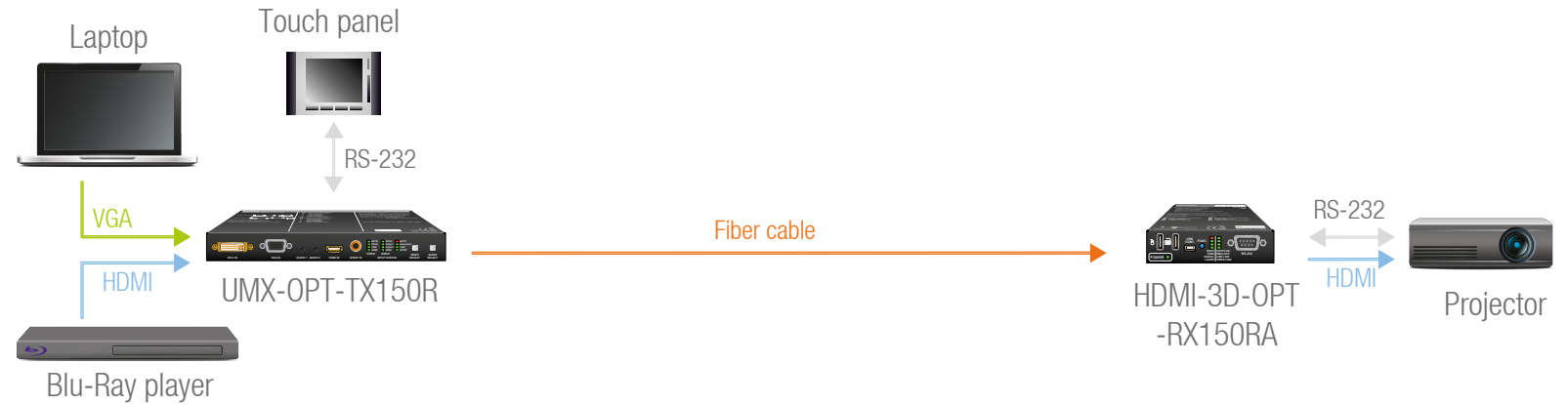

The system consists of the following: a Blu-Ray player and a laptop as sources, a programmable touch panel as a controller, then a Lightware UMX-OPT-TX150R and HDMI-3D-OPT-RX150R as the optical extenders, then a projector as a sink device. The touch panel has three buttons. The desired functions of the buttons are that they can power on and off the projector, and switch between the inputs. Let's examine the detailed solution.

Three types of the touch panel's commands:

- (): settings of the touch panel / not sent /
- []: command to the projector / sent via RS-232 to UMX-OPT-TX150R then via fiber optical cable to the projector /
- { }: command to the UMX-OPT-TX150R / sent via RS-232 to UMX-OPT-TX150R /

Initializing:

First of all the touch panel can control the projector only if RS-232 settings are the same for the touch panel and the projector.

Commands:	Comments:
(set_RS-232)	/* Set the appropriate RS-232 settings which are fit to the UMX-OPT-TX150R and the projector as well. */

INFO: 57600, 38400, 19200 or 9600 Baud, 8 bit, 1stop bit, no parity. These settings are fit to the UMX-OPT-TX150R.

Button 1 (Power on the projector):

The touch panel can control the projector only if the UMX-OPT-TX150R is in pass-through mode.

Commands:	Comments:
{RS232=PASS} {projector_on}	/* Set the UMX-OPT-TX150R in pass-through mode */ /* Power on the projector */

Button 2 (Select the HDMI input):

The touch panel can only control the UMX-OPT-TX150R if that is in control mode.

Commands:	Comments:
{RS232=CONTROL} {4@1 AV}	/* Set the UMX-OPT-TX150R in control mode */ /* Select the HDMI input on the UMX-OPT-TX150R */

Button 3 (Power off the projector):

The touch panel can control the projector only if the UMX-OPT-TX150R is in pass-through mode.

Commands:	Comments:
{RS232=PASS} {projector_off}	/* Set the UMX-OPT-TX150R in pass-through mode */ /* Power off the projector */

5

Software Control – Lightware Device Controller

The device can be controlled by a computer through the USB port Lightware Device Controller (LDC). The software can be installed on a Windows PC or Mac OS X. The application and the User's Manual can be downloaded from www.lightware.eu. The Windows and the Mac versions have the same look and functionality.

- ▶ INSTALL AND UPGRADE
- ▶ ESTABLISHING THE CONNECTION
- ▶ CROSSPOINT MENU
- ▶ INPUT PARAMETERS SETTINGS WINDOW
- ▶ OUTPUT PARAMETERS SETTINGS WINDOW
- ▶ EDID MENU
- ▶ SETTINGS MENU
- ▶ TERMINAL WINDOW

The device can be controlled using the Lightware Device Controller (LDC) from a Windows PC or laptop through USB and RS-232 port. The software can be installed on a Windows PC or Mac OS X. The application and the User's manual can be downloaded from www.lightware.eu. The Windows and the Mac versions have the same look and functionality.

The device can be controlled by a computer through the Ethernet and RS-232 port using Lightware Device Controller (LDC). The software can be installed on a Windows PC or Mac OS X. The application and the User's manual can be downloaded from www.lightware.eu. The Windows and the Mac versions have the same look and functionality.

5.1. Install and Upgrade

Installation for Windows OS

Run the installer. If the User Account Control drops a pop-up message click **Yes**.

During the installation you will be prompted to select the type of the installation: **normal** and the **snapshot** install:

Normal install	Snapshot install
Available for Windows and Mac OS X	Available for Windows
The installer can update only this instance	Cannot be updated
Only one updateable instance can exist for all users	More than one different version can be installed for all users

Comparison of installation types

ATTENTION! Using the Normal install as the default choice is highly recommended.

Installation for Mac OS X

INFO: After the installation, the Windows and the Mac application has the same look and functionality. This type of the installer is equal with the Normal install in case of Windows and results an updateable version with the same attributes.

Mount the DMG file with double clicking on it and drag the LDC icon over the Applications icon to copy the program into the Applications folder. If you want to copy the LDC into another location just drag the icon over the desired folder.

Upgrading of LDC

Step 1. Run the application.

The **Device Discovery** window appears automatically and the program checks the available updates on Lightware's website and opens the update window if the LDC found updates.

The current and the update version number can be seen at the top of the window and they are shown in this window even with the snapshot install.

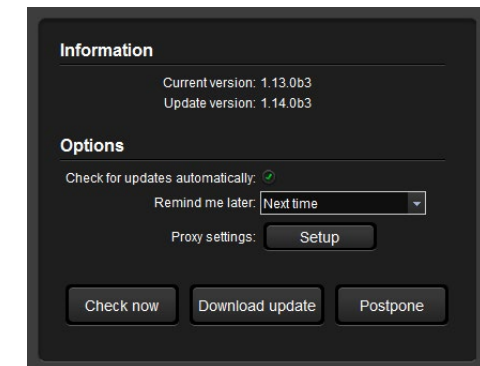

Step 2. Set the desired update setting in the **Options** section.

- If you do not want to check for the updates automatically, uncheck the **circle**, which contains the green tick.
- If you want to postpone the update, a reminder can be set with different delays from the **drop down list**.
- If the proxy settings traverse the update process, set the proper values then click the **OK** button.

Step 3. Click the **Download update** button to start the upgrading.

The updates can be checked manually by clicking the **Check now** button.

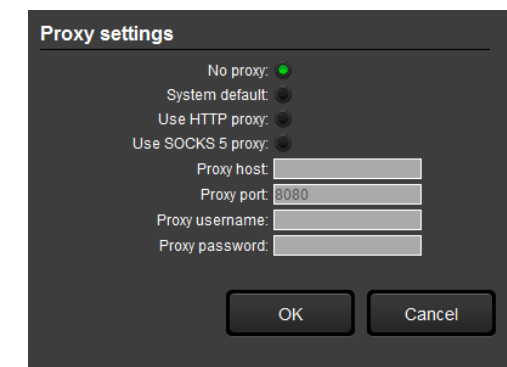

5.2. Establishing the Connection

- Step 1.** Connect the device to a computer via USB or RS-232.
- Step 2.** Run the controller software; device discovery window appears automatically.
- Step 3.** Select the unit from the discovered USB devices or under Serial devices; when the device is connected through RS-232 click on the **Query** button next to the desired serial port to display the device's name and serial number. Double click on the transmitter or select the device and click on the **Connect** button.

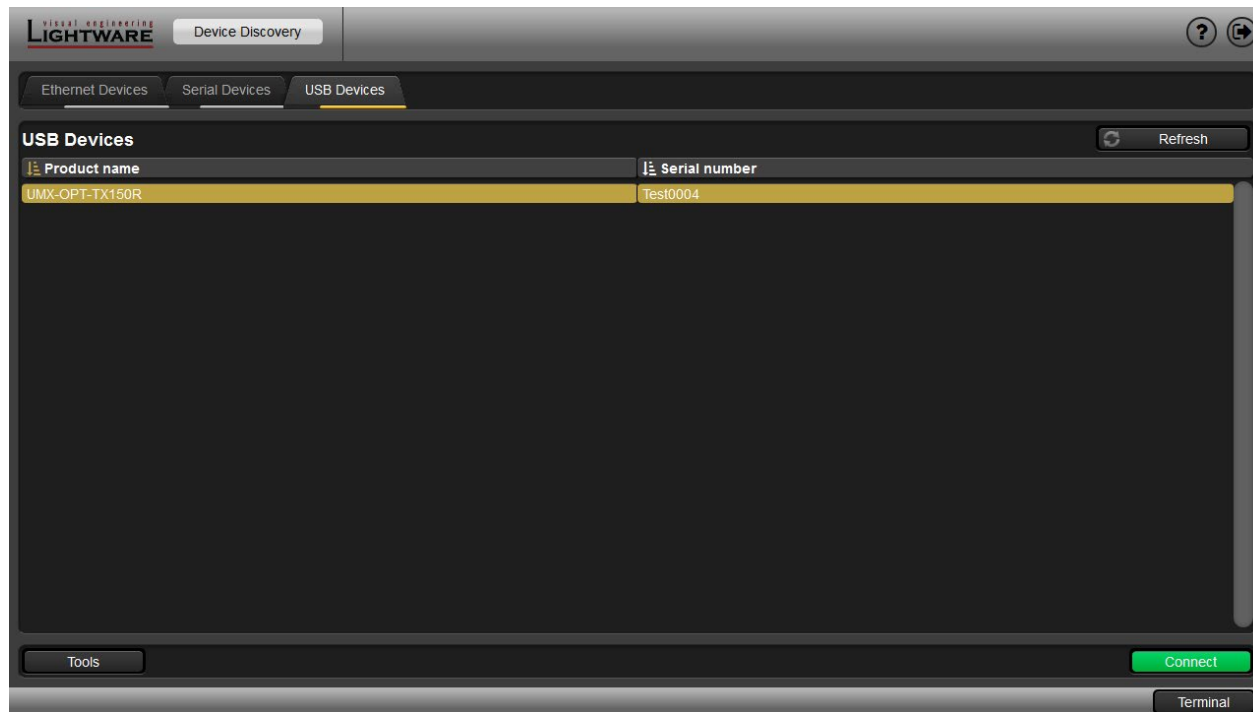

Device Discovery Window in LDC

INFO: Lightware Device Controller software can only connect to the extender if it is in control mode. If the UMX-OPT-TX150R is in pass-through mode, the software cannot communicate with it and cannot list it as an available device. If you want to connect to the extender which is in pass-through mode, see details [Set the RS-232 Operation Mode](#) section.

5.3. Crosspoint Menu

When LDC finds the hardware, it determines the product type, and the LDC starts with the default page, showing the Crosspoint menu.

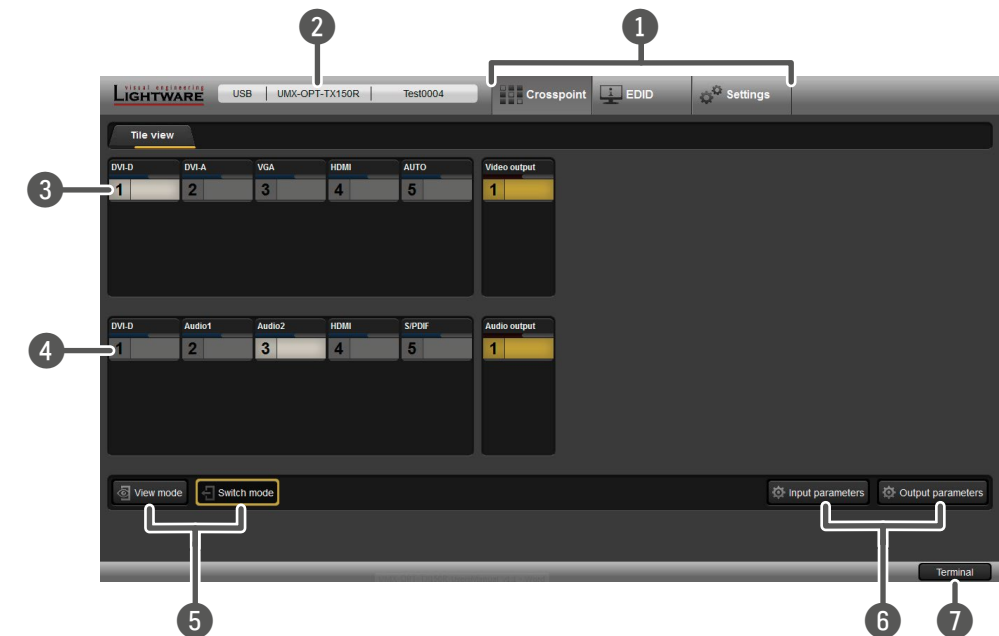

- 1 Main menu** The available menu items are displayed. The active one is showed with dark grey background color.
- 2 Information ribbon** The label shows the device label and serial number. Device discovery window can be displayed by clicking on this ribbon.
- 3 Video input ports** Each tile represents a video input port. The tile below the port shows the current crosspoint setting; if the port is switched to the output, the color of the tile is white, otherwise grey.
- 4 Audio input ports** Each tile represents an audio input port. The tile below the port shows current crosspoint setting; if the port is switched to the output, the color of the tile is white, otherwise grey. Dark grey means the audio port is not allowed to embed in the current video input port.
- 5 View mode/ Switch mode** In View mode crosspoints settings are not modifiable, in Switch mode the input port is changeable. Yellow frame shows the current setting.
- 6 Input/Output parameters** Clicking on this button opens the actual video and audio port properties window.
- 7 Terminal** Clicking on this button opens the Terminal window where the device can be controlled through LW2 protocol commands.

5.4. Input Parameters Settings Window

By clicking on the Input parameters button a dialog window appears showing the parameters for the active input. This section shows the available settings and status information by port types.

5.4.1. Reload Factory Defaults

Current input: Reloads the default values to the currently selected input.

5.4.2. General Settings

HDCP Enable

The HDCP capability can be enabled or disabled on the input port with using the HDCP enable check box. This can prevent unnecessary HDCP encryption with certain source devices. Note that only unprotected content can be played on the source if this setting is disabled. For more information about HDCP handling see [HDCP Management](#) section.

No Sync Color

The port generates a solid 640x480 resolution image when there is no incoming signal and the No Sync enable check box is marked. The color of this picture can be set here. Double click on the colored field, a new window will appear. Choose the desired color then click the **OK** button to apply changes. Click the **Cancel** button to discard changes and close the window.

This function is available also with protocol command (see in [Set the No Sync Picture Properties](#) section).

No Sync Enable

If the No Sync enable check box is marked the port generates a solid 640x480 resolution image when there is no incoming signal. If the check box is unmarked and there is no incoming signal the device does not give the video signal and the hotplug on the output.

The service menu ([Set the RS-232 Operation Mode](#) section) allows enabling or disabling this function but only for all the input ports (the color set is not allowed in the service menu).

INFO: Audio transmission is available with video transmission only. If the No sync picture is disabled the audio transmission is available with valid incoming video signal only.

5.4.3. Input Port Status

Connection status of the selected input port is shown here. (Type of the video signal, HDCP encryption, the source 5V, sync type)

INFO: These fields are filled automatically by the device after the examination of the signal.

5.4.4. Video Signal Info

Resolution, color depth and colorspace of the incoming signal are shown here.

The 'Timing type' and 'Timing ID' fields show which parameters are used to digitize the incoming analog signal. The input port measures the incoming analog signal and determines the timings. If the parameters need adjustment, it can be done on the right side at 'analog options'. In this case the 'Timing ID' field changes to 'user modified' unless the parameters are not saved.

INFO: These fields are filled automatically by the device after the examination of the signal.

5.4.5. Audio Signal Info

Information about the embedded audio signal is shown here (Audio signal, audio type, sampling frequency, channel allocation).INFO: These fields are filled automatically by the device after the examination of the signal.

5.4.6. Analog Video Options

Analog video signals are digitized on the input. The timing parameters can be adjusted here if needed. Timing presets can be saved for each resolution separately.

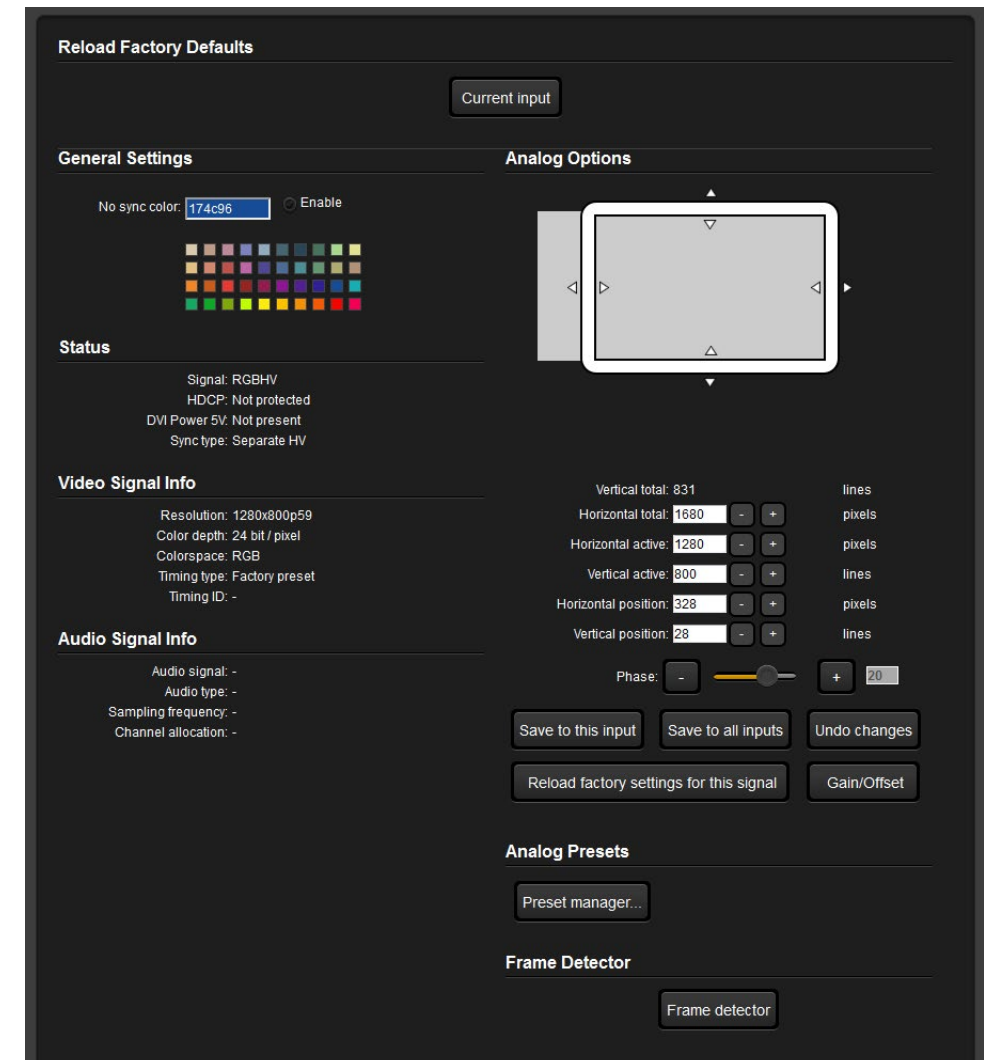

Screen Position

Screen position is an easy way to fit the visible area of the analog video signal and the sink device. Actually the horizontal and vertical positions (Horizontal position and Vertical position) can be set with two different methods:

- Click on the arrows to increase or decrease the H.Pos and V.Pos values, or
- Move the mouse over the visible (grey) area. Click and hold with the left mouse button. Drag the visible area to the desired position.

Analog Video Timings

Vertical total: Total line number of the whole image. (The visible and the blanking area)

Horizontal total: Total pixel number of the whole image. (The visible and the blanking area)

Horizontal active: Pixel number of the visible image.

Vertical active: Line number of the visible image.

Horizontal/ Vertical position: Horizontal and vertical position values specify the location of the visible area on the sink device. Black border on any side of the picture can mean wrong settings for the position of the visible area.

Phase: In case of unclear picture changing pixel phase can solve the problem. Changing the source device or the cable can cause pixel phase shifting.

Presets

User's settings for analog video timings can be set into the UMX-OPT-TX150R as presets. One preset contains the following

values which can be set by the user: Horizontal active, Vertical active, Horizontal position, Vertical position and Phase.

Presets can be assigned for each different resolution to the actual or to all inputs.

Save to this input: Preset assigned for the current resolution will be set to the actual input.

Save to all inputs: Preset assigned for the current resolution will be set to all inputs.

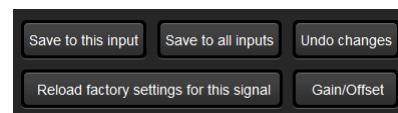

Undo changes: Backup the last saved preset values. If there were no saved values it sets up the original settings.

Reload factory settings for this signal: Clear the saved preset for this resolution from all the inputs, and sets up the original settings.

Analog Gain / Offset

Analog gain / offset window allows users to correct the gain and the offset values if the automatic mode doesn't give a good result. Gain and offset settings method are the same:

Step 1. Select the manual mode if the settings need to be changed.

Step 2. Tick the Lock channels if the three components might change with the same extent.

Step 3. Use the mouse to drag the slider and set to the desired position.

Step 4. Click on the Save button to store the changes.

Preset Manager

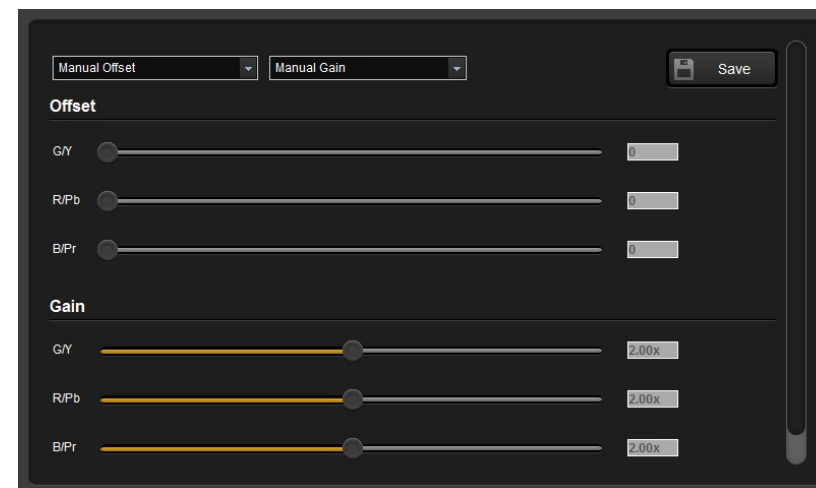

User can handle the saved values with the built-in preset manager. Click on the **Preset manager...** button and a new window will open. Presets are shown for the actual input port. **Delete record from this port:** Delete the selected preset from only the current port.

Delete record from all ports: Don't need to open every preset manager for each input port to delete an unwanted preset. Just click the **Delete record from all ports** button. Never mind if the selected preset has different number in the other input properties list, because the device search by the current resolution.

Clone record to all port: Don't need to reload the saved values and save to all port. It can be done with only one step. Just select the desired

preset and click the **Clone record to all port** button.

Columns: User can select which fields will be shown for the saved presets. The default fields are: Name, V.freq, H.freq, V.pos, H.pos, V.size, H.size and Phase.

INFO: Analog timing presets can be saved only for the analog input port so **Delete record from all ports** and **Clone record to all port** buttons are kept for compatibility reasons.

5.4.7. Frame Detector

Click the frame detector button to view the measured detailed timings on the incoming signal.

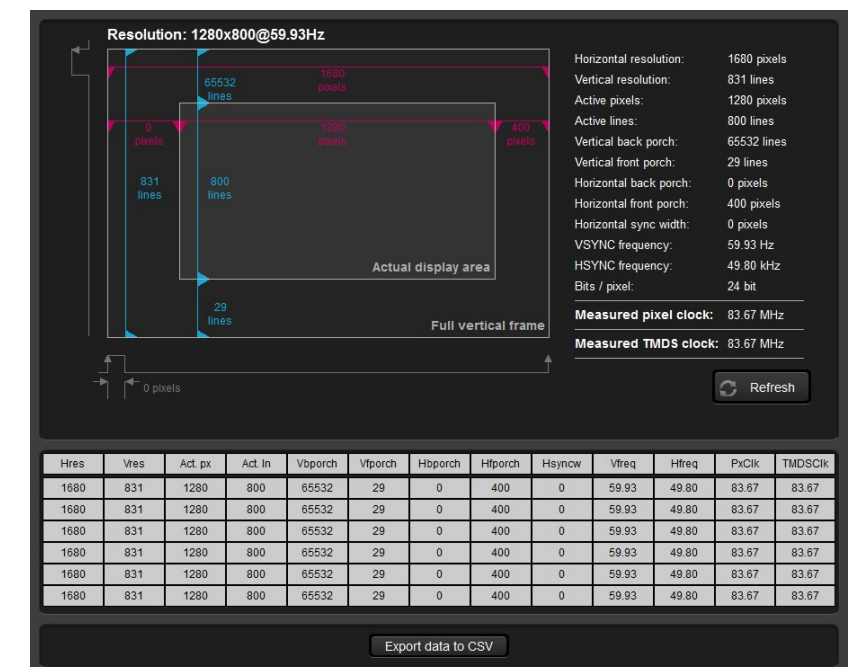

The dark grey zone is the blanking area (non-visible) and the light grey colored zone is the picture (visible area).

INFO: Resolution is given by the source devices always means the picture (visible area) resolution and the refresh rate means the VSYNC frequency.

If the **Refresh** button is clicked on then the UMX-OPT-TX150R samples and calculates the analog signal values again.

Click on the **Close** button to close the Frame detector window and step back to the current input port settings window.

INFO: The frame detector only gives information about video signal from the selected input.

5.5. Output Parameters Settings Window

By clicking on the Video parameter label a dialog window appears showing the parameters for the corresponding output.

5.5.1. Set Signal Properties

Mode

The **Mode** can be set to Auto, DVI, HDMI, HDMI 30 bit DC, HDMI 36 bit DC. The Auto option sets the signal mode regarding to the attached display device's EDID and the incoming signal.

HDCP

The **HDCP** option sets the HDCP encryption on the output. The Auto setting applies encryption when the incoming signal is encrypted. The Always setting forces encryption on any incoming video signal.

5.5.2. General

Information about the signal and the connection status is shown here.

INFO: These fields are filled automatically by the device after the examination of the signal.

5.5.3. Display

Information retrieved from the connected display's EDID is shown.

INFO: These fields are filled automatically by the device after the examination of the signal.

5.5.4. Supported Audio Formats

The connected display's supported audio Formats are shown based on the read EDID.

5.5.5. Autoselect Settings

Video Auto Select

The video Autoselect settings are available in this drop-down menu. It can be:

- NonPriority, First detect,
- DVI-D priority or
- HDMI priority.

For detailed description about video Autoselect please read [Video Autoselect Mode](#) chapter.

Audio Auto Select

The audio Autoselect settings are available in this drop-down menu. It can be:

- Static select (Digital + embedded, DVI-A + Audio 1, VGA + Audio 2),
- First detect (Embedded, S/PDIF, Analog 2),
- Priority detect (Embedded, S/PDIF, Analog 2),
- Priority detect (S/PDIF, Embedded, Analog 2),
- Priority detect (Embedded, Analog 2),
- Priority detect (S/PDIF, Analog 2),
- Fix select (Embedded),
- Fix select (Analog 1),
- Fix select (Analog 2),
- Fix select (S/PDIF),

For detailed description about audio Autoselect please read [Audio Autoselect Mode](#) chapter.

5.5.6. Optical Module Properties

Optical parameters give information about the device's optical module and the type of the connector.









INFO: These fields are filled automatically by the device after the examination of the signal.

5.6. EDID Menu

EDID management can be accessed by selecting the EDID menu. There are two panels: left one contains Source EDIDs, right one contains Destination places where the EDIDs can be emulated or copied.

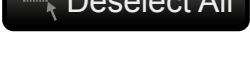

Control Buttons

 Save	Exporting an EDID (save to a file)		Executing EDID emulation or copying (Transfer button)
 Upload	Importing an EDID (load from a file)		Deleting EDID (from User memory)
 Info	Display EDID Summary window		Selecting all memory places in the right panel
 Edit	Opening Advanced EDID Editor with the selected EDID		Selecting none of the memory places in the right panel
 Create	Opening Easy EDID Creator		

5.6.1. EDID Operations

After the list is downloaded, the current status is shown. The EDID memory consists of four parts.

The **Emulated EDID List** shows the currently emulated EDIDs for each input. It contains the input description, manufacturer, resolution, monitor name, source name for each input separately. The source column displays the memory location that the current EDID was routed from.

The **Dynamic EDID List** contains the resolution, manufacturer and vendor name of the display devices connected to device's output. The device remembers the last display device's EDID, so there is an EDID shown even if there is no device attached to the transmitter's output at the moment.

The **Factory EDID List** shows the factory memory locations (01# - 20#) with preprogrammed EDID.

The **User EDID List** shows the memory locations (51# - 66#) which can be used by the user to save custom EDIDs.

Any source reads the EDID from the Emulated EDID memory for the corresponding port. The user can select an EDID with the rotary switches to the desired input's memory location. This is called EDID switching. There are two types of the emulation: static and dynamic.

- **Static EDID** emulation happens, when an EDID from the Factory or User EDID list is selected by the Rotary switches (#1 .. #). In this case the Emulated EDID will remain the same until the user emulates another EDID.
- **Dynamic EDID** emulation can be enabled by selecting #0 on the EDID Rotary switch. The attached monitor's EDID is copied to the INPUT, if a new monitor is attached to the output, the emulated EDID changes automatically.

Changing Emulated EDID

To change the emulated EDID use the EDID Rotary switches on the rear panel of the device. For more information see [EDIDs Are Referred with Rotary Switches](#) chapter.

INFO: If dynamic emulation is established, the emulated EDID will be changed on the input every time a new monitor is connected to the output. If the monitor is disconnected from the output, the last EDID remains emulated for the source. This feature helps especially rental technicians or system integrators to keep the source continuously transmitting the signal, and adopt the system for new incoming display devices.

INFO: Power ON/OFF cycle will not affect the emulated EDID or other settings.

INFO: EDID routing procedure causes a status change, hence it is reported back to the control software within 2-3 seconds.

Learning an EDID

The system is able to learn the EDID from a connected display device and store it in one of the user programmable memory locations.

Step 1. Select the Dynamic EDID list from the Source panel (line will be highlighted with yellow).

Step 2. Select the User EDID list from the Destination panel (line will be highlighted with yellow).

Step 3. Press  button to save the EDID into the selected User memory.

Exporting an EDID

Source EDID can be downloaded as a file (*.bin, *.dat or *.edid) to the computer.

Step 1. Select the desired **EDID** from the Source panel (line will be highlighted with yellow).

Step 2. Press the **Save** button to open the dialog box and save the file to the computer.



Importing an EDID

Previously saved EDID (*.bin, *.dat or *.edid file) can be uploaded to the user memory:

Step 1. Press the **User** button on the top of the Source panel and select a **memory** slot.

Step 2. Press the **Upload** button below the Source panel.

Step 3. Browse the file in the opening window then press the **Open** button. Browsed EDID is imported into the selected User memory.



ATTENTION! The imported EDID overwrites the selected memory place even if it is not empty.

Deleting EDID(s)

The EDID(s) from User memory can be deleted as follows:

Step 1. Press **User** button on the top of the Destination panel.

Step 2. Select the desired **memory** slot(s); one or more can be selected (**Select All** and **Select None** buttons can be used). The EDID(s) will be highlighted with yellow.

Step 3. Press the **Delete selected** button to delete the EDID(s).



5.6.2. EDID Summary Window

Select an EDID from Source panel and press Info button to display EDID summary.

General	
EDID version:	1
EDID revision:	3
Manufacturer ID:	SAM (Samsung Electric Company)
Product ID:	8E09
Monitor serial number:	Not present
Year of manufacture:	2012
Week of manufacture:	9
Signal interface:	Digital
Separate Sync H&V:	-
Composite sync on H:	-
Sync on green:	-
Serration on VS:	-
Color depth:	Undefined
Interface standard:	Not defined
Color spaces:	RGB 4:4:4 & YCrCb 4:4:4
Aspect ratio:	0.56
Display size:	52 cm X 29 cm

5.6.3. Editing an EDID

Select an EDID from Source panel and press Edit button to display Advanced EDID Editor window. The editor can read and write all descriptors, which are defined in the standards, including the additional CEA extensions. Any EDID from the device’s memory or a saved EDID file can be loaded into the editor. The software resolves the raw EDID and displays it as readable information to the user. All descriptors can be edited, and saved in an EDID file, or uploaded to the User memory. For more details about EDID Editor please visit our website (www.lightware.eu) and download EDID Editor user’s manual.



Basic EDID	
Vendor / Product Information	
Display Parameters	
Power Management and Features	
Gamma / Color and Established Timings	
Standard Timings	
Preferred Timing Mode	
2nd Descriptor Field	
3rd Descriptor Field	
4th Descriptor Field	
CEA Extension	
General	
Video Data	
Audio Data	
Speaker Allocation Data	
HDMI	
Colorimetry	
Detailed Timing Descriptor #1	
Detailed Timing Descriptor #2	
Detailed Timing Descriptor #3	
Detailed Timing Descriptor #4	
Detailed Timing Descriptor #5	
Detailed Timing Descriptor #6	
Save EDID	

EDID Byte Editor										
	0	1	2	3	4	5	6	7	8	9
0	00	FF	FF	FF	FF	FF	FF	00	4C	2D
10	8E	09	00	00	00	00	09	16	01	03
20	80	34	1D	78	0A	7D	D1	A4	56	50
30	A1	28	0F	50	54	BD	EF	80	71	4F
40	81	C0	81	00	81	80	95	00	A9	C0
50	B3	00	01	01	02	3A	80	18	71	38
60	2D	40	58	2C	45	00	09	25	21	00
70	00	1E	66	21	56	AA	51	00	1E	30
80	46	8F	33	00	09	25	21	00	00	1E
90	00	00	00	FD	00	18	4B	1A	51	17
100	00	0A	20	20	20	20	20	00	00	
110	00	FC	00	54	32	34	42	33	30	31
120	0A	20	20	20	20	01	6C			

5.6.4. Creating an EDID

Since above mentioned Advanced EDID Editor needs more complex knowledge about EDID, Lightware introduced a wizard-like interface for fast and easy EDID creation. With Easy EDID Creator it is possible to create custom EDIDs in four simple steps. By clicking on the **Create** button below Source panel, **Easy EDID Creator** is opened in a new window. For more details about EDID Editor please visit our website (www.lightware.eu) and download EDID Editor user's manual.

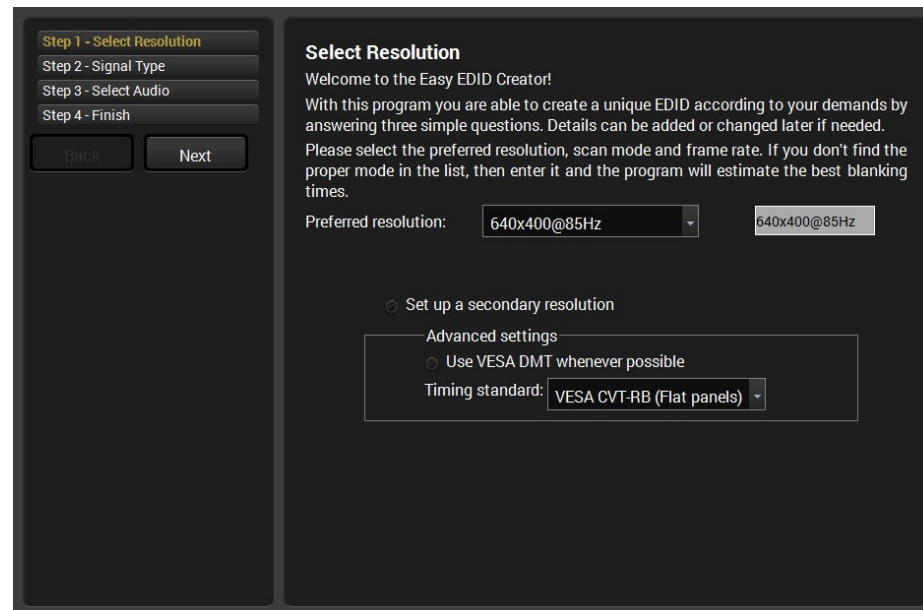

5.7. Settings Menu

5.7.1. Device Information

The serial number, installed firmware version and the hardware revision of the device is shown under the Device Information tab.

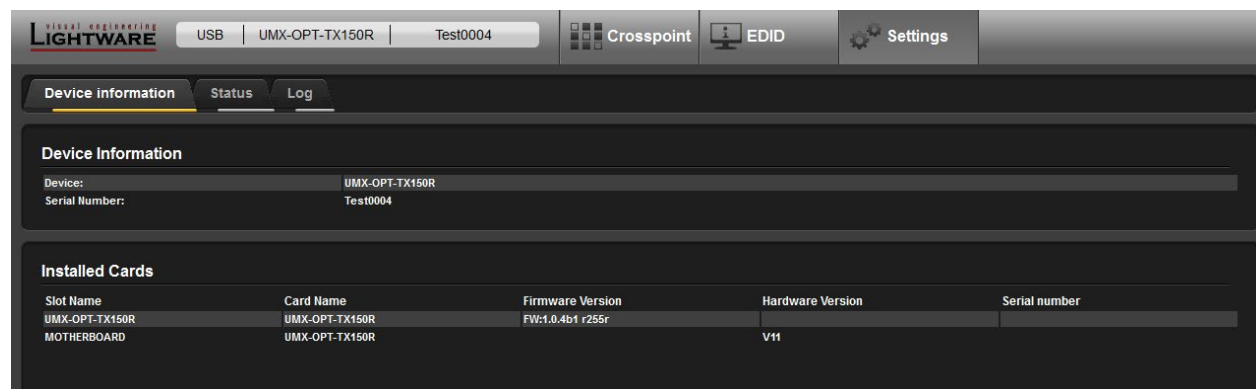

5.7.2. Status

The current temperature of the device is displayed on Status tab.

5.7.3. Log

Events logged by the device and report generators can be found on Log tab. There are two sections: Report and Log viewer.

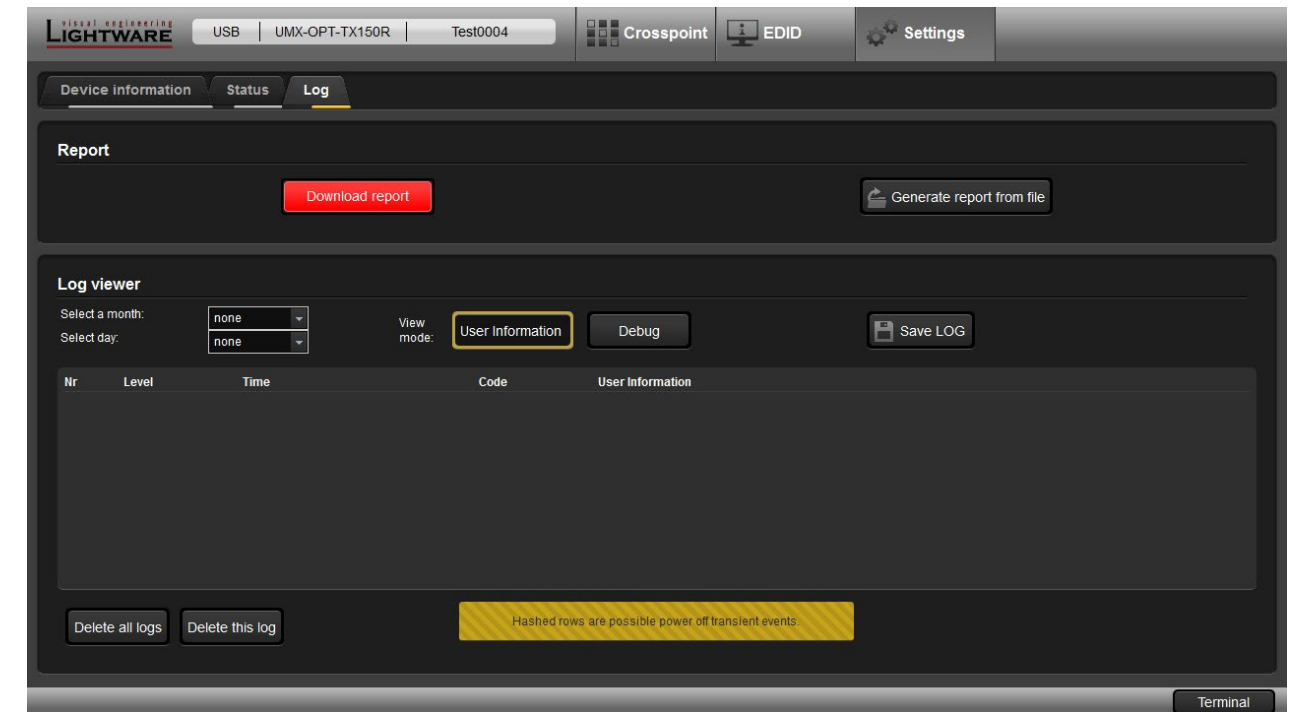

Report Section

LDC is able to collect information from the device and save it to a report file. This information package can be sent to Lightware support team when a problem may arise with the device.

Download report

LDC collects the needed information; this may take up to a few minutes.

After generating the report, a **Save as** dialog box appears. Select the folder where you want to save the report file. The default file name can be changed.

The report contains the following device-dependent information (if available):

- Device type and serial number,
- Firmware version,
- All EDID headers and status (emulated, dynamic, factory, user).

Generate Report From File

The LDC is able to send a custom command file to UMX-OPT-TX150R. The command file can be generated by Lightware support. This is needed when some special commands have to be used for configuring the device or troubleshooting.

If a command file was sent:

Step 1. Save it to the computer.

Step 2. Click to the **Generate report from file** button. A browser window will be opened.

Step 3. Choose the command file. Another browser window will be appeared where the generated result file will be saved.

INFO: This function is only for special troubleshooting cases.

Log Viewer Section

Log files saved by the transmitter can be downloaded and viewed with this function.

User information is selected in the view mode (frame is highlighted with yellow), the columns in the list are the followings: error level, time (nominal time to give information about the order of the events), error code, user information.

The data is displayed in a structured, user-friendly way, this mode is recommended.

When **Debug** view mode is selected (frame is highlighted with yellow) there are some additional columns: error parameter, processor task identifier, occurrences and extra information. This data display for special troubleshooting cases.

The error log can be saved in a CSV file on the computer by the Export to CSV file button.

5.8. Terminal Window

This general purpose terminal is intended mainly for testing and debugging purposes. All commands can be used here that are discussed in the programmer's reference. The command text can be typed directly.

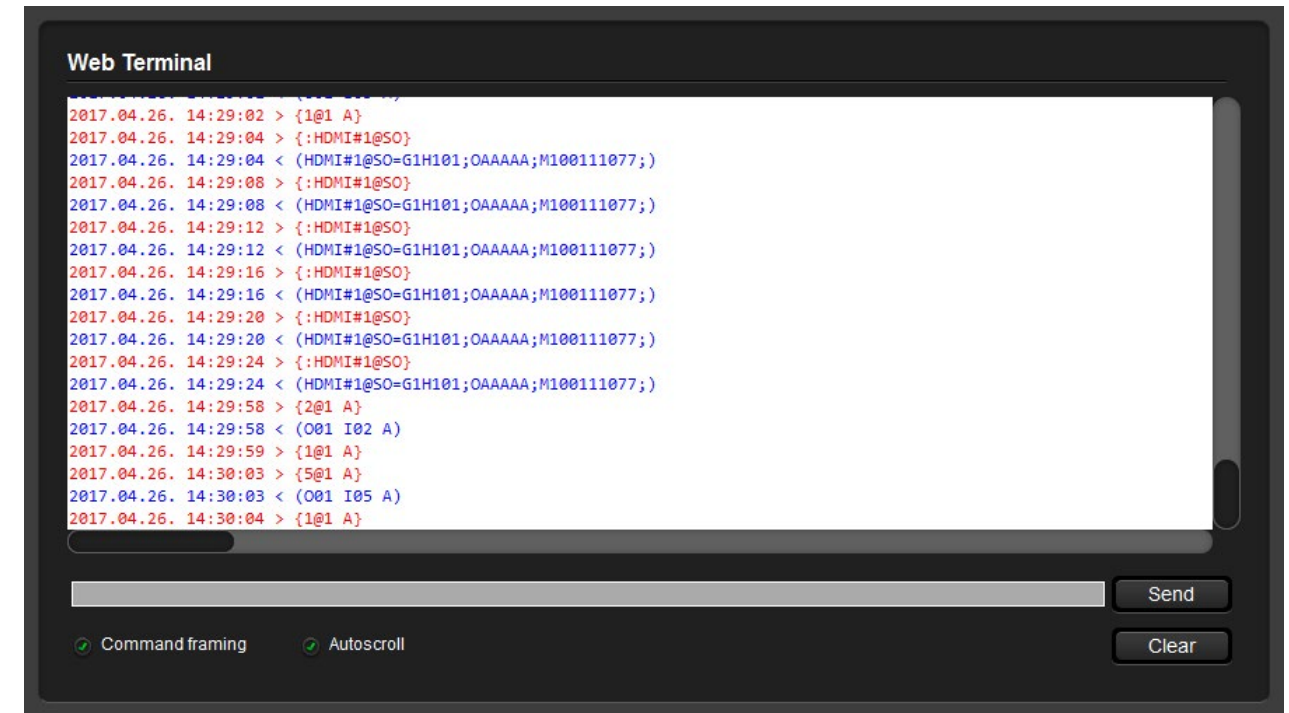

By default commands are automatically surrounded by framing brackets. Every sent command and every received response gets an arrow (-> or <-) prefix, and has different font colors in order to help to distinguish.

The timecode in every row shows the exact time when the command was sent or the response received.

If the Command framing check box is unchecked, you can send multiple commands together, however in this case you have to type in the framing brackets manually.

The terminal can be also opened after starting the LDC - press the Terminal button on the Device discovery page on the bottom of the window.

TIPS AND TRICKS: The typed commands can be "browsed" when the cursor is in the command line and you press the up button on the keyboard. The commands are stored until the LDC is closed.

6

LW2 Programmers' Reference

Lightware UMX-OPT-TX150R can be controlled with external devices which can communicate according to the extender protocol. The supported LW2 commands are described in this chapter.

- ▶ [SERIAL PORT SETTINGS](#)
- ▶ [LW2 PROTOCOL DESCRIPTION](#)
- ▶ [STATUS AND IDENTIFICATION COMMANDS](#)
- ▶ [SYSTEM COMMANDS](#)
- ▶ [EDID ROUTER COMMANDS](#)
- ▶ [CONTROL COMMANDS](#)
- ▶ [ERROR LOG RELATED COMMANDS](#)
- ▶ [INPUT PROPERTIES](#)
- ▶ [OUTPUT PROPERTIES](#)
- ▶ [ERROR RESPONSES](#)
- ▶ [LW2 COMMANDS - QUICK SUMMARY](#)

6.1. Serial Port Settings

UMX-OPT-TX150R uses RS-232 communication port. D-SUB connector pin assignments can be found in [RS-232 Port](#) chapter. The device uses standard RS-232 interface with the following default settings:

57600 Baud, 8 data bit, 1 stop bit, no parity

The serial port baud rate can be changed with rear panel rotary switch ([Speed of the Serial Communication](#) section) or protocol command - in case of #0 BAUD RATE rotary state ([Change RS-232 Baud Rate](#) section).

6.2. LW2 Protocol Description

The devices accept commands surrounded by curly brackets - { } - and responds with data surrounded by round brackets - () - only if a command was successfully executed. All input commands are converted to uppercase, but respond commands can contain upper and lower case letters as well.

Format	Explanation
<in>	Input number in 1 or 2 digit ASCII Format (01, 5, 07, 16, etc.)
<out>	Output number in 1 or 2 digit ASCII Format
<in ² >	Input number in 2 digit ASCII Format (01, 02, 10, 12 etc.)
<out ² >	Output number in 2 digit ASCII Format (01, 02, 10, 12 etc.)
<loc>	Location number in 1, 2 or 3 digit ASCII Format
<id>	ID number in 1 or 2 digit ASCII Format
<id ² >	ID number in 2 digit ASCII Format
< <i>italic</i> >	Italic parameters are optional
CrLf	Carriage return, Line feed (0x0D, 0x0A)
•	Space character (0x20)
→	Each command issued by the controller
←	Each response received from the transmitter

6.3. Status and Identification Commands

6.3.1. View Product Type

Description: Identification of the device. Type 'i' or 'I' then the transmitter responds its name.

Format	Example
Command {I}	→ {i}
Response (<PRODUCT_TYPE>)CrLf	← (I:UMX-OPT-TX150R)CrLf

Legend: <PRODUCT_TYPE> shows type.

Explanation: The connected device is a UMX-OPT-TX150R.

6.3.2. View Serial Number

Description: The extender responds its 8-digit serial number.

Format	Example
Command {S}	→ {s}
Response (<SERIAL_NUMBER>)CrLf	← (SN:10170321)CrLf

Legend: <SERIAL_NUMBER> shows the serial number of the extender.

Explanation: The connected device's serial number is 10170321.

INFO: Only the last 4 numbers are written onto the back of the transmitter.

6.3.3. View Firmware Version of the CPU

Description: View the CPU firmware revision.

Format	Example
Command {F}	→ {f}
Response (FW:<FW_VER><S>)CrLf	← (FW:1.0.4b1 r255r)CrLf

Legend: <FW_VER> is the firmware version. It is followed by <s> string which may indicate special versions. <s>=r indicates standard version.

Explanation: The connected device's firmware version is 1.0.4b1.

6.3.4. View Installed Controllers' Firmware

Description: Shows the firmware revisions of the installed controllers.

Format	Example
Command {FC}	→ {fc}
Response (CF•END)CrLf	← (CF END)CrLf

Explanation: There is no installed controller. This command is reserved for compatibility reasons.

6.3.5. View Device's Temperature

Description: Queries temperature status.

Format	Example
Command {ST}	→ {st}
Response (ST•CPU•<DESC>•<TEMP>)CrLf	← (ST CPU N/A N/A N/A N/A N/A 29.4C)CrLf

Legend: <DESC> reserved for compatibility reasons.

<TEMP> The inner temperature.

Explanation: Internal temperature is 29.4 Celsius.

6.3.6. View CPU Firmware Compile Time

Description: Shows the CPU firmware compile time.

Format	Example
Command {CT}	→ {ct}
Response (Compiled:<DATE>•<TIME>•Build:<tag>)CrLf	← (Compiled: Sep 12 2014 11:58:00 Build:1)CrLf

Legend: <DATE> Month, Day and Year

<TIME> Hours, minutes and seconds

<tag> Identification number of the firmware

Explanation: The firmware was made in 12.09.2014, 11:58:00 and the identification number of the firmware is 1.

6.3.7. View Installed I/O Boards

Description: Shows the hardware name and revision of the installed cards. The number of responses varies regarding the frame size (number of slots).

Format	Example
Command {IS}	→ {is}
Response (SL#•0•<MB_DESC>)CrLf	← (SL# 0 UMX-OPT-TX150R V11) CrLf
(SL•END)CrLf	← (SL END) CrLf

Legend: Slot 0 represents the motherboard.

<MB_DESC> The motherboard description contains the name and the version number.

Explanation: The extender reports that it has one motherboard called UMX-OPT-TX150R and its version number is V11.

6.3.8. Query All Port Status

Description: Shows the actual status of all input and output ports.

Format	Example
Command {PS}	→ {ps}
Response (PS●<INPUT_D>,<OUTPUT_D>)CrLf	← (PS 0000,0)CrLf

Legend: <INPUT_D> contains 4 decimal numbers. Each number must be 0.
 <OUTPUT_D> contains 1 decimal number. It must be 0.
 The input and output state tables are separated with a comma “,” character.

Explanation: This command is reserved for compatibility reasons.

6.4. System Commands

6.4.1. Query Current Control Protocol

Description: Shows the control protocol.

Format	Example
Command {P_?}	→ {p_?}
Response (CURRENT●PROTOCOL●●#<x>) CrLf	← (CURRENT PROTOCOL = #1)CrLf

Legend: <x> stands for the active protocol.

Explanation: Protocol 1 is active here.

INFO: User can query the protocol only. This command is reserved for compatibility reasons.

6.4.2. Change RS-232 Baud Rate

ATTENTION! LW2 commands modify the baud rate only if the rotary switch is set #0. In other case the LW2 commands do not change the baud rate. From #1 to #9 the setting can be read from the state of the rotary switch (for more details see [Speed of the Serial Communication](#) section).

Description: The RS-232 baud rate can be set when the BAUD RATE rotary has #0 (software set) state. The command has to be sent with the earlier baud rate but the response comes with the new baud rate.

Format	Example
Command {RS232BAUD=<rate>}	→ {RS232BAUD=9600}
Response (RS232BAUD=<rate>)CrLf	← (RS232BAUD=9600)CrLf

Explanation: The device RS-232 port is set to 9600 baud.

Possible settings:

<rate>	Baud rate
9600	9600 baud
19200	19200 baud
38400	38400 baud
57600	57600 baud
115200	115200 baud

default

6.4.3. Query RS-232 Baud Rate

ATTENTION! LW2 commands modify the baud rate only if the rotary switch is set #0. In other case the LW2 commands do not change the baud rate. From #1 to #9 the setting can be read from the state of the rotary switch For more details see [Speed of the Serial Communication](#) chapter.

Description: The RS-232 baud rate can be checked. It works via RS-232 as well, but if it is used the command has to be sent with the appropriate baud rate.

Format	Example
Command {RS232BAUD=?}	→ {RS232BAUD=?}
Response (RS232BAUD=<rate>)CrLf	← (RS232BAUD=57600)CrLf

Legend: Please read [Change RS-232 Baud Rate](#).

Explanation: The device communicates with 57600 baud on the RS-232 port.

6.4.4. Reload Factory Defaults

Description: Factory default settings can be reloaded for different functions separately. Multiple functions can be entered.

Format	Example
Command {FACTORY=<f1>;<f2>;...;<fx>}	→ {factory=xpoint;iocards;edidmem}
Response (FACTORY●<f1>...)CrLf	← (FACTORY IOCARD...)CrLf
(FACTORY●<f2>...)CrLf	← (FACTORY XPOINT...) CrLf
...	← (FACTORY EDIDMEM...) CrLf
(FACTORY●<fx>...)CrLf	

Legend: <f1>, <f2> are the names of the functions which have to be reset to factory default. Any number of <fx> can be entered, separated by semicolons.

<fx>	Restores Factory Settings to	Additional response
XPOINT	Crosspoint table and configuration	none
GENERAL	Elevelsend, RS-232 working mode, baud rate	none
IOCARDS	All I/O settings	none
EDIDMEM	Clear User and Dynamic EDIDs	(DE_OK) (E_SW_OK) ... (E_SW_OK)
ALL	Restores all of the factory settings listed above	none

Explanation: Factory default settings reloaded for crosspoint and I/O card configurations and emulated EDIDs.

INFO: The response may contain additional messages as the transmitter makes the configurations. These responses can be omitted.

INFO: After resetting the needed parameters, the device restarts. In case of USB connection reconnecting is always necessary.

WARNING! Reloading GENERAL factory defaults AFFECTS the serial operation mode and the RS-232 baud rate options as well. The default operation mode is the PASS mode and the default baud rate is 57600 baud in the UMX-OPT-TX150R. If the previous serial settings differ from the default ones, please set up the necessary values after reboot with protocol commands.

6.4.5. Set the RS-232 Operation Mode

Description: This command sets the RS-232 port operation mode.

Format	Example
Command {RS232=<mode>}	→ {rs232=control}
Response (RS232=<mode>)CrLf	← (RS232=CONTROL)CrLf

Legend: <mode> Two kinds of operation modes can be:

<CONTROL> The CPU in the transmitter can receive commands and send responses.

<PASS>The serial connectors on the transmitter and on the receiver are linked together.

Explanation: The device can be controlled via RS-232 port.

6.4.6. Query the RS-232 Operation Mode

Description: This command queries the current RS-232 operation mode.

Format	Example
Command {RS232=?}	→ {rs232=?}
Response (RS232=<mode>)CrLf	← (RS232=PASS)CrLf

Legend: <mode> Two kinds of operation modes can be:

<CONTROL> The CPU in the transmitter can receive commands and send responses.

<PASS> The serial connectors on the transmitter and on the receiver are linked together.

Explanation: The device can be controlled via RS-232 port.

6.4.7. Clear HDCP Key Cache

Description: The device stores the HDCP keys from the connected devices. These cached keys can be cleared with this command.

Format	Example
Command {:HDCPRESET}	→ {:hdcpreset}
Response (Done)CrLf	← (Done)CrLf

Explanation: HDCP key cache is cleared.

INFO: This function is useful when too many keys were cached and a connected source device cannot accept so many keys.

6.4.8. Count HDCP Keys

Description: If there is an HDCP source on the HDMI input of the device, the device can ask the source whether it can handle <num> piece of sink devices.

Format	Example
Command {HDCPTEST<in>@<num>}	→ {hdcptest4@9}
Response (HDCPTEST=<resp>)CrLf	← (HDCPTEST=SUCCESS)CrLf

Legend:

- <in> input port where the key counting will be executed. This input port must be selected.
- <num> the number of the HDCP keys
- <res> Result of the HDCP key counting:

SUCCESS: The source on the <in> input can handle <num> HDCP sink devices.

FAIL: The source on the <in> input cannot handle <num> HDCP sink devices.

UNAVAILABLE: If the <in> input isn't a HDCP compliant input (e.g. VGA), the key counting function isn't available.

NOAUTH: If the <in> input is a HDCP compliant input but there is no connected source, the device cannot execute the key counting.

Explanation: The source on the 4th input can handle 9 HDCP sink devices.

6.4.9. Restart Transmitter

Description: The extender can be restarted without unplugging power.

Format	Example
Command {RST}	→ {rst}
Response (Booting...)CrLf	← (Booting...)CrLf
(<name>●READY!)CrLf	← (UMX-OPT-TX150R READY!)

Legend: <name> is the type of the extender

Explanation: The extender reboots and sends a message when it is ready.

INFO: The response can be seen only if the connection to the extender via RS-232 is still alive. The response cannot be seen and reconnect is always necessary in case of USB connection.

6.4.10. View Error List

Description: Shows the basic error list since last boot up.

Format	Example
Command {ELIST=?}	→ {elist=?}
Response (ELIST#<num>●<elevel> ●<code> ●<param>●<occ>)CrLf	← (ELIST#1 Notice BOOTp:6 o:1)CrLf
...	...
(ELIST#<num>●<elevel>●<code> ●<param>●<occ>)CrLf	← (ELIST#2 Notice READY p:0 o:1)CrLf

Legend:

- <num> line number
- <elevel>
 - NOTICE:** The number of the HDCP keys.
 - WARNING:** Possible problem without influencing normal operation.
 - MATTER:** Problem that may lead to further errors.
 - ERROR:** Serious error. Must report to support.
 - FATAL:** Fatal error. Normal operation is not possible.
- <code> short name for type of log entry
- <param> technical parameter
- <occ> occurrence number for this type of log entry

Explanation: There are no errors only standard notices that occur on boot up.

INFO: The error list can contain **Notices** and **Warnings** under normal operation. These entries do not mean that there is any problem with the transmitter!

6.4.11. Configure Remote Alerts

Description: The device logs different levels of errors. Configure which level of errors has to be sent out as an alarm message.

	Format	Example
Command	ELEVELSEND#<p>=<0>,<1>,<2>,<3>,<4>}	→ {ELEVELSEND#1=0,0,1,1,1}
Response	(ELEVELSEND#<p>=<0>,<1>,<2>,<3>,<4>)CrLf	← (ELEVELSEND#1=0,0,1,1,1)CrLf

Legend:

<p>	Adjusted control interface must be 1 = RS-232
<0>	NOTICE level events 0 = no immediate message send 1 = immediate message
<1>	WARNING level events 0 = no immediate message send 1 = immediate message
<2>	MATTER level events 0 = no immediate message send 1 = immediate message
<3>	ERROR level events 0 = no immediate message send 1 = immediate message
<4>	FATAL level events 0 = no immediate message send 1 = immediate message

Explanation: The device will send an immediate message on all control interfaces when a **MATTER**, **ERROR** or **FATAL** level error occurs.

6.4.12. Query Level of Remote Alerts

Description: User can check which level of errors has to be sent out as an alarm message.

	Format	Example
Command	{ELEVELSEND#<p>=?}	→ {ELEVELSEND#1=?}
Response	(ELEVELSEND#<p>= <0>,<1>,<2>,<3>,<4>)CrLf	← (ELEVELSEND#1=0,0,1,1,1) CrLf

Legend: Please read [Configure Remote Alerts](#) section.

Explanation: The device will send an immediate message on all control interfaces when a **MATTER**, **ERROR** or **FATAL** level error occurs.

6.4.13. Set the Video Priority Settings

Description: This command sets the video priority order of the Autoselect mode.

	Format	Example
Command	{VIDEOPRIORITY=<vpmode>}	→ {videopriority=4}
Response	(VIDEOPRIORITY=<vpmode>)CrLf	← (VIDEOPRIORITY=4)CrLf

Legend:

<vpmode>	Three kinds of video priority modes can be:
<0>	First detect (factory default) First the device check the DVI-D than VGA than the HDMI video input port. That port will be selected which contains valid video signal.
<1>	DVI-D priority If there is a valid signal on the DVI-D input, this port always will be selected, even if the active port was the VGA or the HDMI input port.
<4>	HDMI priority If there is a valid signal on the HDMI input, this port always will be selected, even if the active port was the VGA, DVI-A or the DVI-D input port.

Explanation: The device uses HDMI priority in the Autoselect mode.

Please see the detailed information in [Video Autoselect Mode](#) section.

6.4.14. Query the Video Priority Settings

Description: This command queries the video priority mode.

	Format	Example
Command	{VIDEOPRIORITY=?}	→ {videopriority=?}
Response	(VIDEOPRIORITY=<vpmode>)CrLf	← (VIDEOPRIORITY=1)CrLf

Legend: Please read [Set the Video Priority Settings](#) section.

Explanation: The device uses DVI-D priority in the Autoselect mode.

6.4.15. Set the Audio Priority Settings

Description: This command sets the audio priority order of the Autoselect mode.

Format	Example
Command {AUDIOPRIORITY=<apmode>}	→ {audiopriority=1}
Response (AUDIOPRIORITY=<apmode>)CrLf	← (AUDIOPRIORITY=1)CrLf

Legend:

<apmode>	Ten kinds of audio priority modes can be:
<0>	Static select: Digital+Embedded, DVI-A+Analog1, VGA+Analog2
<1>	First detect: Embedded, S/PDIF, Analog 2
<2>	Priority: Embedded, S/PDIF, Analog 2
<3>	Priority: S/PDIF, Embedded, Analog 2
<4>	Priority: Embedded, Analog 2
<5>	Priority: S/PDIF, Analog 2
<H1>	Fix select: Embedded
<A1>	Fix select: Analog 1
<A2>	Fix select: Analog 2
<S1>	Fix select: S/PDIF

Explanation: The device uses the first detect method in the Autoselect mode.

Please see [Audio Autoselect Mode](#) section for detailed information about audio Autoselect.

6.4.16. Query the Audio Priority Settings

Description: This command queries the audio priority mode.

Format	Example
Command {AUDIOPRIORITY=?}	→ {audiopriority=?}
Response (AUDIOPRIORITY=<apmode>)CrLf	← (AUDIOPRIORITY=0)CrLf

Legend: Please read [Set the Audio Priority Settings](#) section.

Explanation: The device uses the static select method in the Autoselect mode.

6.5. EDID Router Commands

The EDID router manipulates the EDID memory, which has memory locations that are assigned to specific input or output ports. For more details please read [EDID Memory Structure](#) section.

ATTENTION! Emulated EDIDs can be switched with the rotary switches only.

6.5.1. Save EDID to User Memory (Learn EDID)

Description: Learn EDID from <loc2> to <loc1>.

Format	Example
Command {<loc1>:<loc2>}	→ {u3:d1}
Response (E_SW_OK)CrLf	← (E_SW_OK)CrLf
(E_S_C) CrLf	← (E_S_C)CrLf

Legend: <loc1> has to be 'Uxx'.

<loc2> can be 'Fxx' or 'Uxx' or 'Dxx'.

Explanation: EDID from the output 1 is saved to user EDID #3.

INFO: The transmitter sends (E_S_C) only if the new EDID is different from the earlier one.

6.5.2. View Emulated EDIDs on All Inputs

Description: Shows the currently emulated EDIDs for all the inputs. The value at the given index (<in1>, <in2>, <in3>, <in4>) shows which EDID is used on that particular input.

Format	Example
Command {VEDID}	→ {vedid}
Response (VEDID●<in1>●<in2>●<in3>●<in4>)CrLf	← (VEDID F005 D001 U001 U002)CrLf

Legend: All <inx> indexes show a <loc> which was copied to that input port.

Explanation: F005 (Factory preset EDID F05) is emulated on the input 1. EDID from output is dynamically emulated on input 2. First and the second User EDID are emulated on input 3 and input 4.

6.5.3. Watch EDID Validity Table

Description: Shows EDID validity table, which contains information about the EDID memory states.

Format	Example
Command {WV<type>}	→ {wv*}
Response (EV<type>● <VALIDITY_TABLE>)CrLf	← (EVU 3111111111111111)CrLf ← (EVD 1)CrLf ← (EVE 1111)CrLf

Legend:

<type>	<name>	Response length
F	Factory preset EDIDs	20
U	User saved EDIDs	16
D	Dynamic EDIDs	1
E	Emulated EDIDs	4
*	All U, D and E EDIDs	

INFO: <type> can be only capital letter.

Each number represents the EDID validity state for the corresponding memory location.

Value	Description
0	Invalid EDID
1	Valid EDID
3	Changed EDID

Explanation: There is one '3' in the first row on the 1st position. This means that the user EDID is changed since the last EDID query on that port.

INFO: If a changed EDID is queried by the {WH} command (see the next section), its value returns to '1'.

INFO: EDID deleting means the universal EDID will be uploaded to the deleted EDID's place.

6.5.4. View EDID Header

Description: Shows basic information about EDIDs in the memory.

Format	Example
Command {WH<loc>}	→ {whe1}
Response (EH#<loc>•<EDID_HEADER>)CrLf	← (EH#E1 LWR 1920x1080@60HzUniv_HDMI_DC)CrLf

Legend: Depending on <loc> the query can be for one EDID, all EDID in the block.

<loc>	Result	Response
Fxx	Factory EDID query	header for one EDID
Uxx	User EDID query	
Dxx	Dynamic EDID query	
Exx	Emulated EDID query	
F*	All Factory preset EDIDs	headers for all (20) Factory EDIDs
U*	All User saved EDIDs	headers for all (16) user EDIDs
D*	All Dynamic EDIDs	header from the output (1)
E*	All Emulated EDIDs	headers from all the four inputs (4)

<EDID_HEADER> consists of 3 fields separated by spaces:

PNPID code: The three letter abbreviation of the manufacturer

Preferred resolution: The resolution and refresh rate stored in the preferred detailed timing block.

Name: The name of display device stored in product descriptor.

Explanation: Shows the EDID from the input 1.

6.5.5. Download EDID Content from the Transmitter

Description: EDID hex bytes can be read directly. The transmitter will issue the whole content of the EDID present on memory location <loc> (256 bytes).

Format	Example
Command {WE<loc>}	→ {wef1}
Response (EB#<loc>•<B1>•<B2>•...•<B256>)CrLf	← (EB#F1 00 FF FF FF FF FF FF 00 32 F2 00 00 00 ... 00 92) CrLf

Legend: <B1>..<B256> are space separated hex characters represented in ASCII Format.

Explanation: Full EDID from memory location 1 is downloaded.

6.5.6. Upload EDID Content from the Transmitter

Description: EDID hex bytes can be written directly to the user programmable memory locations.

Sequence:

Step 1. Prepare the device to accept EDID bytes to the specified location <loc> with command {WL#<loc>}

Step 2. Device responds that it is ready to accept EDID bytes with (E_L_S)CrLf

Step 3. Send 1 block of EDID (1 block consist of 8 bytes of hex data represented in ASCII Format) with command: {WB#<num>•<B1>•<B2>•<B3>•<B4>•<B5>•<B6>•<B7>•<B8>}

Step 4. The device acknowledges with response (EL#<num>)

Step 5. Repeat steps 3 and 4 to send the remaining 31 blocks of EDID (32 altogether)

Step 6. After the last acknowledge, the device indicates that the EDID status changed by sending (E_S_C) CrLf

Format	Example
Command {WL#<loc>}	→ {wl#u3}
Response (E_L_S)CrLf	← (E_L_S) CrLf
Command {WB#1•<B1>•<B2>•<B3>•<B4>•<B5>•<B6>•<B7>•<B8>}	→ {wb#1 00 FF FF FF FF FF FF 00}
Response (EL#<num>)CrLf	← (EL#1)CrLf
Command {WB#2•<B9>•<B10>•<B11>•<B12>•<B13>•<B14>•<B15>•<B16>}	→ {wb#2 38 A3 8E 66 01 01 01 01}
Response (EL#<num>) CrLf	← (EL#2)CrLf
...	...
Command {WB#32•<B249>•<B250>•<B251>•<B252>•<B253>•<B254>•<B255>•<B256>}	→ {wb#32 36 59 42 0A 20 20 00 96}
Response (EL#<num>) CrLf	← (EL#32)CrLf
Response (E_S_C) CrLf	← (E_S_C)CrLf

Legend: <num> represents the sequential number of every 8 byte part of EDID. <num> is between 1 and 32. <B1>..<B256> are the bytes of EDID.

Explanation: Full EDID uploaded to memory location U3.

6.5.7. Delete EDID from Memory

Description: Clear EDID from memory location <loc>.

Format	Example
Command {DE<loc>}	→ {deu3}
Response (E_SW_OK)CrLf	← (E_SW_OK)CrLf
(DE_OK)CrLf	← (DE_OK)CrLf
(E_S_C)CrLf	← (DE_OK)CrLf

Legend: Depending on <loc>, one EDID, or all EDIDs in a block can be cleared.

<loc>	Result
Fxx	Not valid! Factory EDID cannot be deleted. No response.
Uxx	Specified User EDID is deleted.
Dxx	Dynamic EDID is the Universal EDID by factory default and it cannot be deleted.
Exx	Specified Emulated EDID is selected by a rotary switch and it cannot be deleted.
F*	Not valid! Factory EDID cannot be deleted. No response.
U*	All User EDIDs are deleted.
D*	UMX-OPT-TX150R contains only one Dynamic EDID and it cannot be deleted..
E*	All Emulated EDIDs are selected by rotary switches and they cannot be deleted.

Explanation: Third user EDID is cleared from memory.

INFO: Only user EDIDs can be deleted. Deleting means the factory EDID (Universal HDMI or Analog EDID) will be loaded into the desired user EDID memory.

6.6. Control Commands

Description: The following commands with <A/V/AV> option can take effect in multiple layers, according to their parameters. Depending on 'A' or 'V' it can change only the Audio, or only the Video layer; or 'AV' changes both.

INFO: <A/V/AV> option usually can be skipped for legacy purposes. In this case using router commands the router changes all (Video & Audio) layers, but using status commands it displays information about only the Video layer. Please use AV option, when available.

6.6.1. Switch One Input to One Output

Description: This command switches the output to an input.

Format	Example
Command {<in>@<out>●<A/V/AV>}	→ {2@1 av}
Response (0<out?>●I<in?>●<A/V/AV>)CrLf	← (001 I02 AV)CrLf

Legend: <A/V/AV>: **Layer select:**
 A: Audio layer
 V: Video layer
 AV: Audio&Video layer

<in> must be 1, 2, 3, 4 or 5 in case of video input
 1: DVI-D video input
 2: DVI-A video input
 3: VGA video input
 4: HDMI video input
 5: Automatic source selection

<in> must be 1, 2, 3, 4 or 5 in case of audio input
 1: DVI-D embedded audio input
 2: Analog audio 1 input
 3: Analog audio 2 input
 4: HDMI embedded audio input
 5: S/PDIF audio input

<out> must be 1

Explanation: The Example shows how to connect both Audio and Video from input 2 to output 1.

INFO: If the command is used without the <A/V/AV> parameter, video layer is switched.

6.6.2. View All Connections on the Output

Description: This command displays the connections on a single or multiple layers.

Format	Example
Command {VC•<A/V/AV>}	→ {vc•av}
Response (ALLV•<in?>)CrLf (ALLA•<in?>)CrLf	← (ALLV•01)CrLf (ALLA•01)CrLf

Legend: Please read in [Switch One Input to One Output](#) section.

Explanation: The response contains all the connections, if both layers are selected the response is two messages. The Example shows that output 1 Audio & Video are connected to input 1 Audio & Video.

INFO: If the command is used without the <A/V/AV> parameter, the response shows only the video layer connections.

6.6.3. Query Autoselect State

Description: This command queries the actual state of the autoselect.

Format	Example
Command {AUTOSELECT=?}	→ {autoselect=?}
Response (AUTOSELECT=<port>)CrLf	← (AUTOSELECT=3)CrLf

Legend: <port>: The number of the selected input port:
 S: Searching is in progress and there is no selected video input.
 1: DVI-I input is selected.
 3: VGA input is selected.
 4: HDMI input is selected.
 N/A: The device is not in autoselect mode.

Explanation: The device is in autoselect mode and the VGA input is selected.

6.7. Error Log Related Commands

UMX-OPT-TX150R logs the error events into an EPROM memory. The device emulates a standard FAT16 file system with a fix directory and file structure.

M:\LOG\1970_01\1.CSV

M:\ virtual drive letter, root directory

LOG directory

1970_01 directory, contains the log file

1.CSV the log file (Format of the log file is CSV - comma separated values)

INFO: The drive letter, directory names and file names are given with upper case and the commands are case sensitive.

6.7.1. List a Directory

Description: List the content of a directory.

Format	Example
Command {SD_DIR=<path>}	→ {sd_dir=M:\LOG}
Response (DIR1•<cont>)CrLf (DIR_END)CrLf	← (DIR1 1970_01 <DIR>)CrLf ← (DIR_END)CrLf

Legend: <path>: The path of the directory with absolute reference. There are only two directory: LOG and 1970_01 and the drive letter is always M:\.

<cont>: The content of the given directory.

Explanation: LOG directory contains the 1970_01 directory.

6.7.2. List the Log File

Description: The command lists the saved error events. The log file is always available.

Format	Example
Command {SD_GETT=M:\LOG\1970_01\1.CSV}	→ {SD_GETT=M:\LOG\1970_01\1.CSV}
Response (LOG#1 ...)CrLf (LOG#2...)CrLf ... (LOG•END)CrLf	← (LOG#1 level;time;code;param;task;occurency;info)CrLf ← (LOG END)CrLf

Legend: LOG#1 The header of the log file.

LOG#x Every LOG# row is different event.

Explanation: The log file doesn't contain any event. The header (LOG#1) is shown only.

6.7.3. Clear the Log File

Description: This command clears the error events but keeps the empty log file with header and the directory structure.

Format	Example
Command {SD_Format}	→ {sd_Format}
Response (OK)CrLf	← (OK)CrLf

Explanation: The log file content is cleared.

6.8. Input Properties

The following commands are setting up the properties of the input ports. If only one or a few parameters have to be modified, the protocol enables to mask the other parameters, so they can stay untouched. To mask a parameter use "x" or "X" as its value.

Example: {:ANALOG#2@SI=x;x;x;210;x;} Only change the horizontal position on the input port 2.

INFO: If the input port is not a selected, active port and this port is affected by an input command the response will be N/A.

6.8.1. Set Input Port Properties

Description: This command queries the actual state of the autoselect.

Format	Example
Command {:DVII#<in>@<S/ A>I=<VIDEO>;<X1>;<X2>;<HDCP>}	→ {:dvii#1@si=x;x;x;1}
Response (DVII#<in>@<S/A>I=<VIDEO>;<X>;<X>; <HDCP>;<STATUS>;<SOURCE>; <ATIM1/DCS>;<ATIM2/DRES>; <ARES/HAUDIO>;<HASAMP><HCH> CrLf	← (DVII#1@SI=D;x;x; 1;3;H; 20;1920x1080p60; P;48;) CrLf

Legend:

<S/A>: **Affected ports:**
S = single selected input
A = all inputs

<VIDEO>: **Video source: (read-only)**
A = Automatic analog (color space detected by sync)
D = Digital (HDMI / YPbPr)

Explanation: This command enables the HDCP encryption.

INFO: Video source gives information about the source. It is a read-only parameter. Automatic analog (A) setting available with analog VGA INPUT and Digital (D) setting available with HDMI INPUT.

<X1>: Reserved for compatibility reasons. Don't care.

<X2>: Reserved for compatibility reasons. Don't care.

INFO: The following parameters are available above 1.0.9 firmware version.

INFO: HDCP setting available only on the HDMI input port.

<HDCP>: HDCP capability:
0 = disabled,
1 = enabled.

INFO: The following parameters cannot be set, they only appear in response.

<STATUS> **Status** (hexadecimal):

bit 0: (LSB): Power 5V
0 = not detected
1 = detected
bit 1: Source signal HDCP:
0 = not protected
1 = protected
bit 2: Don't care
bit 3: Don't care

<SOURCE> **Actual video source:**

H = HDMI
D = DVI
R = RGBHV (analog signal, separate HV sync)
C = Component signal (analog signal, embedded sync)
- = No video detected.

Source dependent parameters:

Analog signal properties are displayed, when <SOURCE> = R / C:

<ATIM1> **Analog timing1:**
0 = SMTPE standard
1 = User saved preset
2 = EDID detailed timing
3 = Factory preset
4 = GTF formula
5 = User modified (not saved)

<ATIM2> **Analog timing2:** (depending on <ATIM1>)
<ATIM1> = 0 -> SMTPE record number
<ATIM1> = 1 -> User preset number
<ATIM1> = 2 -> Detailed timing number
<ATIM1> = 3 -> Factory preset number
<ATIM1> = 4 -> Fixed zero.

<ARES> **Resolution string.** (Example: 1600x1200p60)

Digital signal properties are displayed, when <SOURCE> = H / D:

<DCS> 2 byte hexadecimal number:
bit 0 = 1: Color depth: 30 bit/pixel (not supported)
bit 1 = 1: Color depth: 36 bit/pixel
bit 2 = 1: Color depth: 48 bit/pixel (not supported)
bit 0&1&2 = 0: Color depth: 24 bit/pixel
bit 4: Color space: YCbCr422
bit 5: Color space: YCbCr444

<DRES> **Incoming resolution string.** (Example: 1600x1200p60)

If HDMI signal present <SOURCE> = H, there are more HDMI specific parameters:

<HAUDIO> **HDMI Audio properties:**

0 = no audio
 P = 2 channel stereo (L-PCM)
 M = Multichannel-PCM (M-PCM)
 S = Compressed audio
 H = HBR audio
 D = DST audio (not supported)
 E = DSD audio (not supported)

<HASAMP> If <HAUDIO> not S or H: HDMI audio sample rate in kHz.

<HAUDIO> = S (Compressed) multiply by 32,

<HAUDIO> = H (HBR) multiply by 4

32	32	kHz
44	44,1	kHz
48	48	kHz
88	88,2	kHz
96	96	kHz
176	176,4	kHz
192	192	kHz

<HCH> Contains CEA-861 compatible channel assignment, if M-PCM signal present:

0x00	-	-	-	-	-	-	FR	FL
0x01	-	-	-	-	-	LFE	FR	FL
0x02	-	-	-	-	FC	-	FR	FL
0x03	-	-	-	-	FC	LFE	FR	FL
0x04	-	-	-	RC	-	-	FR	FL
0x05	-	-	-	RC	-	LFE	FR	FL
0x06	-	-	-	RC	FC	-	FR	FL
0x07	-	-	-	RC	FC	LFE	FR	FL
0x08	-	-	RR	RL	-	-	FR	FL
0x09	-	-	RR	RL	-	LFE	FR	FL
0x0A	-	-	RR	RL	FC	-	FR	FL
0x0B	-	-	RR	RL	FC	LFE	FR	FL
0x0C	-	RC	RR	RL	-	-	FR	FL
0x0D	-	RC	RR	RL	-	LFE	FR	FL
0x0E	-	RC	RR	RL	FC	-	FR	FL
0x0F	-	RC	RR	RL	FC	LFE	FR	FL
0x10	RRC	RLC	RR	RL	-	-	FR	FL
0x11	RRC	RLC	RR	RL	-	LFE	FR	FL
0x12	RRC	RLC	RR	RL	FC	-	FR	FL
0x13	RRC	RLC	RR	RL	FC	LFE	FR	FL
0x14	FRC	FLC	-	-	-	-	FR	FL
0x15	FRC	FLC	-	-	-	LFE	FR	FL

0x16	FRC	FLC	-	-	FC	-	FR	FL
0x17	FRC	FLC	-	-	FC	LFE	FR	FL
0x18	FRC	FLC	-	RC	-	-	FR	FL
0x19	FRC	FLC	-	RC	-	LFE	FR	FL
0x1A	FRC	FLC	-	RC	FC	-	FR	FL
0x1B	FRC	FLC	-	RC	FC	LFE	FR	FL
0x1C	FRC	FLC	RR	RL	-	-	FR	FL
0x1D	FRC	FLC	RR	RL	-	LFE	FR	FL
0x1E	FRC	FLC	RR	RL	FC	-	FR	FL
0x1F	FRC	FLC	RR	RL	FC	LFE	FR	FL

Where:

FL	Front Left
FC	Front Center
FR	Front Right
FLC	Front Left Center
FRC	Front Right Center
RL	Rear Left
RC	Rear Center
RR	Rear Right
RLC	Rear Left Center
RRC	Rear Right Center
LFE	Subwoofer

6.8.2. Query Input Port Properties

Description: Check status of the input ports.

	Format	Example
Command	{:DVII#<in>@<S/A>I=?}	→ {:dvii#1@si=?}
Response	DVII#<in>@<S/A>I= <VIDEO>; <X1>; <X2>; <HDCP>; <STATUS>; <SOURCE>; <ATIM1/DCS>; <ATIM2/DRES>; <ARES/HAUDIO>; <HASAMP>; <HCH>);CrLf	← (DVII#1@SI= D; x; x; 1; 3; H; 20; 1920x1080p60; P; 48;);CrLf

Legend: Please read [Set Input Port Properties](#) section.

Explanation: This command queries the HDMI input port properties.

6.8.3. Set Analog Timing Properties

Description: This command changes the setup of the analog timing data.

Format	Example
Command {: ANALOG# <in>@<S/A>I= <PHS>;<FHS>; <HS>;<VS>; <HP>;<VP>;}	→ {: analog#2 @si= 10;2160; 1600;1200; 455;41;}
Response (DVII# <in>@<S/A>I= <PHS><FHS>; <HS>;<VS>; <HP>;<VP>; <LCF>; <FORM>;<VSP>;<HSP>; <FPS>;)CrLf	← (ANALOG#2 @SI= 10;2160; 1600;1200; 455;41; 1124; P;;; 50;)CrLf

Legend: <S/A>: **Affected ports:**
S = single selected input
A = all inputs

<PHS> Phase
<FHS> Full Horizontal Size
<HS> Horizontal Size
<VS> Vertical Size
<HP> Horizontal Position
<VP> Vertical Position

INFO: The following parameters cannot be set, they only appear in response.

<LCF> Full Vertical Size (Line Count per Field)
<FORM> Format: Progressive or Interlaced
<VSP> Vertical Sync. Polarity
<HSP> Horizontal Sync. Polarity
<FPS> Frame Per Sec in Hz

6.8.4. Query Analog Timing Properties

Description: Check analog timing data of the input ports.

Format	Example
Command {: ANALOG# <in>@<S/A>I=?}	→ {: analog#2 @si=?}
Response (ANALOG# <in>@<S/A>I= <PHS>;<FHS>;<HS>;<VS>; <HP>;<VP>;<LCF>; <FORM>;<VSP>;<HSP>;<FPS>;)CrLf	← (ANALOG#2 @SI= 0;2160;1600;1200; 455;41;1242; P;+;+;60;)CrLf

Legend: Please read [Set Analog Timing Properties](#) section.

6.8.5. Reset Analog Timing Properties

Description: This command resets the analog timing properties.

Format	Example
Command {: ANALOG# <in>@<S/A>I=RESET}	→ {: analog#2 @si=reset}
Response (ANALOG# <in>@<S/A>I= <PHS>;<FHS>;<HS>;<VS>; <HP>;<VP>;<LCF>; <FORM>;<VSP>;<HSP>;<FPS>;)CrLf	← (ANALOG#1 @SI= 0;2160;1600;1200; 455;41;1242; P;+;+;60;)CrLf

Legend: Please read [Set Analog Timing Properties](#) section.

6.8.6. Set Analog Color Properties

Description: Set analog color properties data of the input ports.

Format	Example
Command {: PICTURE# <in>@<S/A>I= <DF_CHA>;<DF_CHB>;<DF_CHC>;<G_CHA>; <G_CHB>;<G_CHC>;<O_CHA>;<O_CHB>; <O_CHC>;<CONT>;<SAT>;<BRIGHT>;<HUE>;)	→ {: picture#2 @si= 1023;1023;1023;1023; 1023;1023;1023;1023; 1023;128;128;0;0;)CrLf
Response (PICTURE# <in>@<S/A>I= <DF_CHA>;<DF_CHB>;<DF_CHC>;<G_CHA>; <G_CHB>;<G_CHC>;<O_CHA>;<O_CHB>; <O_CHC>;<CONT>;<SAT>;<BRIGHT>;<HUE>;)CrLf	← (PICTURE#2 @SI= 1023;1023;1023;1023; 1023;1023;1023;1023; 1023;128;128;0;0;)CrLf

Legend: <S/A>: **Affected ports:**
S = single selected input
A = all inputs

<DF_CHA> Digital fine-clamp for CH-A: 0-4096
<DF_CHB> Digital fine-clamp for CH-B: 0-4095
<DF_CHC> Digital fine-clamp for CH-C: 0-4095
<G_CHA> Gain for CH-A: 0-1023
<G_CHB> Gain for CH-B: 0-1023
<G_CHC> Gain for CH-C: 0-1023
<O_CHA> Offset for CH-A: 0-1023
<O_CHB> Offset for CH-B: 0-1023
<O_CHC> Offset for CH-C: 0-1023
<CONT> Contrast: 0-255
<SAT> Saturation: 0-255
<BRIGHT> Brightness: 0-255
<HUE> Hue: 0-127

INFO: Analog color setting will not be saved automatically. User can save it with the next command.

6.8.7. Save Analog Color Properties

Description: Save analog color properties of the input ports.

Format	Example
Command {: PICTURE# <in>@<S/A>I=SAVE}	→ {: picture#3 @si=save)CrLf
Response (P SAVED)CrLf	← (P SAVED)CrLf
(PICTURE# <in>@<S/A>I= <DF_CHA>;<DF_CHB>;<DF_CHC>; <G_CHA>;<G_CHB>;<G_CHC>; <O_CHA>;<O_CHB>;<O_CHC>; <CONT>;<SAT>;<BRIGHT>;<HUE>;)CrLf	← (PICTURE#3 @SI= 1023;1023;1023; 1023;1023;1023; 1023;1023;1023; 128;128;0;0;)CrLf

Legend: Please read [Set Analog Color Properties](#) section.

6.8.8. Query Analog Color Properties

Description: Check analog color properties data of the input ports.

Format	Example
Command {: PICTURE# <in>@<S/A>I=?}	→ {: picture#2 @si=?}
Response (PICTURE# <in>@<S/A>I= <DF_CHA>;<DF_CHB>;<DF_CHC>; <G_CHA>;<G_CHB>;<G_CHC>; <O_CHA>;<O_CHB>;<O_CHC>; <CONT>;<SAT>;<BRIGHT>;<HUE>;)CrLf	← (PICTURE#2 @SI= 1023;1023;1023; 1023;1023;1023; 1023;1023;1023; 128;128;0;0;)CrLf

Legend: Please read [Set Analog Color Properties](#) section.

6.8.9. Reset Analog Color Properties

Description: Reset analog color properties of the input ports.

Format	Example
Command {: PICTURE# <in>@<S/A>I=FACTORY}	→ {: picture#2 @si=factory}
Response (P SAVED)CrLf	← (P SAVED)CrLf
(PICTURE# <in>@<S/A>I= <DF_CHA>;<DF_CHB>;<DF_CHC>; <G_CHA>;<G_CHB>;<G_CHC>; <O_CHA>;<O_CHB>;<O_CHC>; <CONT>;<SAT>;<BRIGHT>;<HUE>;)CrLf	← (PICTURE#2 @SI= 1023;1023;1023; 1023;1023;1023; 1023;1023;1023; 128;128;0;0;)CrLf

Legend: Please read [Set Analog Color Properties](#) section.

6.8.10. Set Analog Input Audio Parameters

Description: This command changes the setup of the ADC on the audio board.

Format	Example
Command {: AUDIN# <in>@<S/A>I=<VOL>; <BAL>;<GAIN>;<PHS>;<DCF>}	→ {: audin#2 @si=0;50;0;0;0;}
Response (: AUDIN# <in>@<S/A>I=<VOL>; <BAL>;<GAIN>;<PHS>;<DCF>)CrLf	← (AUDIN#2 @SI=0;50;0;0;0;)CrLf

Legend:	<S/A>:	Affected ports: S = single selected input A = all inputs
	<VOL>:	Volume: (default 0) 0, 100, 200, ... , 6200, 6300 where 0 = 0 dB, 6300 = - 63 dB
	<BAL>:	Balance: (default 50) 0 .. 100 %
	<GAIN>:	Gain: (default 0) 0, 3, 6, ... , 21, 24 dB
	<POL>:	Polarity inversion: (default 0) 0 = Normal (phase=0°), 1 = Inverted (phase=180°)
	<DCF>:	Audio DC filter: (default 0) 0 = DC filter off, 1 = DC filter on.

6.8.11. Query Analog Input Audio Properties

Description: This command reads the setup of the ADC on the audio board.

Format	Example
Command {: AUDIN# <in>@<S/A>I=?}	→ {: audin#2 @si=?}
Response (: AUDIN# <in>@<S/A>I=<VOL>; <BAL>;<GAIN>;<PHS>;<DCF>)CrLf	← (AUDIN#2 @SI=0;50;0;0;0;)CrLf

Legend: Please read [Set Analog Input Audio Parameters](#) section.

6.8.12. Set the No Sync Picture Properties

Description: If there is no incoming video signal on the selected input and this function is enabled the device gives a monochrome 640x480p60 picture to the output. This command enables/disables this function and sets the color of the no sync picture with an RGB value on the active input port.

Format	Example
Command {: SETBG# <in>@<S/A>I=<RED>;<GREEN>;<BLUE>;<nss>}	→ {: setbg#1 @si=255;255;0;1}
Response (SETBG#1 @SI= <RED>;<GREEN>;<BLUE>;<nss>)CrLf	← (SETBG#1 @SI=255;255;0;1)CrLf

Legend:	<S/A>:	Affected ports: S = single selected input A = all inputs
	<RED>	Red component of RGB value.
	<GREEN>	Green component of RGB value.
	<BLUE>	Blue component of RGB value.
	<nss>	No Sync screen enable 0 = No Sync screen disable 1 = No Sync screen enable

Explanation: The Example shows how to enable and set yellow colored monochrome no sync picture on the DVI-D input port.

INFO: Enabling/Disabling or setting of the color of no sync picture is available only on the selected active input.

6.8.13. Query the No Sync Picture Properties

Description: This command reads the enabling status and the RGB color code of the no sync picture on the active input port.

Format	Example
Command {: SETBG# <in>@<S/A>I=?}	→ {: SETBG#1 @SI=?}
Response (SETBG#1 @SI= <RED>;<GREEN>;<BLUE>;1)CrLf	← (SETBG#1 @SI=255;255;0;1)CrLf

Legend: Please read [Set the No Sync Picture Properties](#) section.

Explanation: The no sync picture is enabled and its color is the (255, 255, 0) RGB coded yellow on the DVI-D input port.

INFO: Querying of the color of no sync picture is available only on the selected active input.

6.8.14. Query Timings of the Incoming Signal

Description: This command reads out the properties of the incoming signal on the selected input ports.

Format	Example
Command {: GETTIMINGS# <in>@<S/A>=?}	→ {: GETTIMINGS#1 @SI=?}
Response (GETTIMINGS# <in>@<S/A>= <TLW>; <LW>; <HFP>; <HW>; <HBP>; <TH>; <H>; <VFP>; <VW>; <VBP>; <TMDS>; <BPP>;)CrLf	← (GETTIMINGS#1 @SI= 2200; 1920; 89; 44; 147; 1125; 1080; 4; 5; 36; 148352; 24;)CrLf

Legend:	<S/A>:	Affected ports: S = single selected input A = all inputs
	<TLW>:	Total Line Width
	<LW>:	Line Width
	<HFP>:	Hsync Front Porch
	<HW>:	Hsync Width
	<HBP>	Hsync Back Porch
	<TH>	Total Height
	<H>	Height
	<VFP>	Vsync Front Porch
	<VW>	Vsync Width
	<VBP>	Vsync Back Porch
	<TMDS>	TMDS clock in kHz
	<BPP>	Bit/Pixel

6.8.15. Save Preset

Description: This command deletes the desired preset from the analog input port.

Format	Example
Command { :AF#<in>@SI=<IPS> }	→ { :af#2@si=s }
Response (AF SAVED)CrLf	← (AF SAVED)CrLf

Legend: <IPS> **Input port selector:**
 S = Properties will be saved to the current input port.
 A = Properties will be saved to all of the input ports.
 (This option is reserved for compatibility reasons.)

6.8.16. Delete Preset

Description: This command deletes the desired preset from the analog input port.

Format	Example
Command { :AF#<in>@SI=DEL;<PID> }	→ { :af#2@si=DEL;2 }
Response (AF DELETED)CrLf	← (AF DELETED)CrLf

Legend: <PID> Preset ID number

Explanation: The command deletes the numbered 2 preset.

6.8.17. Delete All Presets

Description: This command deletes the desired preset from the analog input port.

Format	Example
Command { :AF#<in>@SI=DEL;255 }	→ { :af#2@si=DEL;255 }
Response (AF DELETED)CrLf	← (AF DELETED)CrLf

Explanation: The command deletes all the presets.

6.8.18. Clone Preset

Description: This command clones the desired preset to all of the input ports.

Format	Example
Command { :AF#<in>@SI=CL;<PID> }	→ { :af#2@si=CL;1 }
Response (AF CLONED)CrLf	← (AF CLONED)CrLf

Legend: <PID> Preset ID number

Explanation: This command is reserved for compatibility reasons.

6.8.19. List Presets

Description: This command reads and lists all the saved presets from the analog VGA input port.

Format	Example
Command { :AF#<in>@<S/A>I=LIST }	→ { :af#2@si=list }
(AF#<in>:<PID>= <BL>;<LCF>;<FCL>;<LCVS>; <SCN>;<VSP>;<HSP>; <VPL>;<HPP>;<VSL>;<HSP>; <FHSP>;<PHS>.)CrLf (AF END)	← (AF#2:1= 3045;1249;1864;3; 0;1;1; 50;495;1200;1600; 2161;23;)CrLf ← (AF END)

Legend: <S/A>: **Affected ports:**
 S = single selected input
 A = all inputs

<PID> Preset ID number
 (8 x 28.6363M) / fhsync
 <BL>: 28.6363M / (256 * fvsync)
 <LCF>: Number of lines in a whole picture
 <FCL>: Number of lines during v.sync
 <LCVS>: Screen scan type:
 0 = progressive
 1 = interlaced
 <VSP> V.sync polarity
 0 = negative
 1 = positive
 <HSP> H.sync polarity
 0 = negative
 1 = positive
 <VPL> Vertical position in lines
 <HPP> Horizontal position in pixels
 <VSL> Vertical size in lines
 <HSP> Horizontal size in pixels
 <FHSP> Full horizontal size in pixels
 <PHS> Phase (0 .. 31)

Explanation: One preset was saved to the input port 2.

6.8.20. Delete Preset from All Input Ports

Description: This command deletes the desired from all analog input ports.

Format	Example
Command {: AF# <in>@SI=DELALL;<PID>} (AF DELETED)CrLf	→ {: af#2 @si=delall;1} ← (AF DELETED)CrLf

Legend: <PID> Preset ID number

Explanation: This command is reserved for compatibility reasons.

6.9. Output Properties

The following commands are setting up the properties of the output ports. If only one or a few parameters have to be modified, the protocol enables to mask the other parameters, so they can stay untouched. To mask a parameter use "x" or "X" as its value.

Example: {:**HDMI#1**@SO=H;x;x;1;} Set output port no. 2 to HDMI 24 bit.

INFO: If the input port is not a selected, active port and this port is affected by an input command the response will be N/A.

6.9.1. Set Output Video Properties

Description: This command is for configuring output port settings.

Format	Example
Command {: HDMI# <out>@<S/A>O= <MODE>; <CSPAC>; <CRANG>; <SUBS>; <HDCP>;}	→ {: HDMI#1 @SO= H;x;x;1;} ← (HDMI#1@SO= G0H100;OHAAA1;) CrLf
Response (HDMI#<out>@<S/A>O= G<CON><MODE><SIG> <HDCP><HPD>; O<MODE><CSPAC> <CRANG>;<SUBS> <HDCP>) M<HSUP><AUTH><REP> <YUV4><YUV2> <AUD><PCM><DC>CrLf	

Legend for command:

<S/A>	Affected ports: S = single-selected output A = all outputs
<MODE>	Output signal mode: A = Automatic (this setting gives a response as D/H/1/2), D = DVI, H = HDMI 24bit, 1 = HDMI 30bit deepcolor, 2 = HDMI 36bit deepcolor.
<CSPAC>	Reserved for legacy reasons. Set 'X' here.
<CRANG>	Reserved for legacy reasons. Set 'X' here.
<SUBS>	Reserved for legacy reasons. Set 'X' here.
<HDCP>	HDCP encryption: A = automatic, 1 = always use.

Legend for response:

G block:	General status information
<CON>	Connection sense: 0 = There is no attached sink device, 1 = Sink device attached (termination is present)
<MODE>	Output signal mode D = DVI, H = HDMI 24bit, 1 = HDMI 30bit deepcolor 2 = HDMI 36bit deepcolor
<SIG>	Signal present 0 = No valid signal is routed to this port, 1 = Valid video signal is present.
<HDCP>	HDCP encryption status 0 = HDCP encryption is inactive, 1 = HDCP encryption is active.
<HPD>	Hotplug detection 0 = Hotplug detect signal is low, 1 = Hotplug detect signal is high.

O block:

<MODE>	Same as in G block.
<CSPAC>	Reserved for legacy reasons. Response is always 'A'.
<CRANG>	Reserved for legacy reasons. Response is always 'A'.
<SUBS>	Reserved for legacy reasons. Response is always 'A'.
<HDCP>	Same as in G block.

M block:

<HSUP>	Attached device (monitor) information 0 = Sink device does not support HDMI 1 = Sink device supports HDMI
<AUTH>	0 = HDCP authentication failed 1 = HDCP authentication is successful
<REP>	0 = Attached device is not an HDCP repeater 1 = Attached device is an HDCP repeater
<YUV4>	0 = Attached device does not support YUV 4:4:4 1 = Attached device supports YUV 4:4:4
<YUV2>	0 = Attached device does not support YUV 4:2:2 1 = Attached device supports YUV 4:2:2
<AUD>	0 = Attached device has no audio capabilities 1 = Attached device has audio capabilities

This field represents a byte in hexadecimal Format. The binary bits show support for different audio bit rates.

<PCM>	bit 0 - Sink device supports 32kHz PCM audio bit 1 - Sink device supports 44kHz PCM audio bit 2 - Sink device supports 48kHz PCM audio bit 3 - Sink device supports 88kHz PCM audio bit 4 - Sink device supports 96kHz PCM audio bit 5 - Sink device supports 176kHz PCM audio bit 6 - Sink device supports 192kHz PCM audio bit 7 - Reserved (Always 0 in this version of protocol)
-------	---

This field is a number in decimal Format. The binary bits show support for different color modes.

<DC>	bit 2 - HDMI deep color 30bits/pixel mode is supported bit 1 - HDMI deep color 36bits/pixel mode is supported bit 0 - YUV444 color space is supported in DC modes
------	---

INFO: The M block can be missing if there is no attached device on output.

6.9.2. Query Output Video Properties

Description: Displays the status for output port.

Format	Example
Command {;HDMI#<out>@<S/A>O=?}	→ {;hdmi#1@so=?}
Response (HDMI#<out>@<S/A>O= G<CON><MODE><SIG> <HDCP><HPD>; O<MODE><CSPAC> <CRANG>;<SUBS> <HDCP>) M<HSUP><AUTH><REP> <YUV4><YUV2> <AUD><PCM><DC>CrLf	← (HDMI#1@SO= G1H111; OAA AAA; M100111 070;)CrLf

Legend: Please read [Set Analog Color Properties](#) section.

6.10. Error Responses

Invalid Input Number

Description: Given input number exceeds the maximum number of inputs or equals zero.

Response: (ERR01)CrLf

Invalid Output Number

Description: Given output number exceeds the installed number of outputs or equals zero.

Response: (ERR02)CrLf

Invalid Value

Description: Given value exceeds the maximum allowed value can be sent.

Response: (ERR03)CrLf

Invalid Preset Number

Description: Given preset number exceeds the maximum allowed preset number.

Response: (ERR04)CrLf

6.11. LW2 Commands - Quick Summary

Status and Identification Commands

Operation	See in chapter	Command
View Product Type	6.3.1	{I}
View Serial Number	6.3.2	{S}
View Firmware Version of the CPU	6.3.3	{F}
View Installed Controllers' Firmware	6.3.4	{FC}
View Device's Temperature	6.3.5	{ST}
View CPU Firmware Compile Time	6.3.6	{CT}
View Installed I/O Boards	6.3.7	{IS}
Query All Port Status	6.3.8	{PS}

System Commands

Operation	See in chapter	Command
Query Current Control Protocol	6.4.1	{P_?}
Change RS-232 Baud Rate	6.4.2	{RS232BAUD=<rate>}
Query RS-232 Baud Rate	6.4.3	{RS232BAUD=?}
Reload Factory Defaults	6.4.4	{FACTORY=<f1>;<f2>;...;<fx>}
Set the RS-232 Operation Mode	6.4.5	{RS232=<mode>}
Query the RS-232 Operation Mode	6.4.6	{RS232=?}
Clear HDCP Key Cache	6.4.7	{;HDCPRESET}
Count HDCP Keys	6.4.8	{;HDCPTEST<in>@<num>}
Restart Transmitter	6.4.9	{RST}
View Error List	6.4.10	{ELIST=?}
Configure Remote Alerts	6.4.11	{ELEVELSEND#<p>=<0>;<1>;<2>;<3>;<4>}
Query Level of Remote Alerts	6.4.12	{ELEVELSEND#<p>=?}
Set the Video Priority Settings	6.4.13	{VIDEOPRIORITY=<vpmode>}
Query the Video Priority Settings	6.4.14	{VIDEOPRIORITY=?}
Set the Audio Priority Settings	6.4.15	{AUDIOPRIORITY=<apmode>}
Query the Audio Priority Settings	6.4.16	{AUDIOPRIORITY=?}

EDID Router Commands

Operation	See in chapter	Command
Save EDID to User Memory (Learn EDID)	6.5.1	{<loc1>:<loc2>}
View Emulated EDIDs on All Inputs	6.5.2	{VEDID}
Watch EDID Validity Table	6.5.3	{WV<type>}
View EDID Header	6.5.4	{WH<loc>}
Download EDID Content from the Transmitter	6.5.5	{WE<loc>}
Upload EDID Content from the Transmitter	6.5.6	{WL#<loc>}
Delete EDID from Memory	6.5.7	{DE<loc>}

Control Commands

Operation	See in chapter	Command
Switch One Input to One Output	6.6.1	{<in>@<out>•<A/V/AV>}
View All Connections on the Output	6.6.2	{VC•<A/V/AV>}
Query Autoselect State	6.6.3	{AUTOSELECT=?}

Error Log Related Commands

Operation	See in chapter	Command
List a Directory	6.7.1	{SD_DIR=<path>}
List the Log File	6.7.2	{SD_GETT=M:\LOG\1970_01\1.CSV}
Clear the Log File	6.7.3	{SD_Format}

Error Log Related Commands

Operation	See in chapter	Command
Set Input Port Properties	6.8.1	{:DVII#<in>@<S/A>I=<VIDEO>;<X1>;<X2>;<HDCP>}
Query Input Port Properties	6.8.2	{:DVII#<in>@<S/A>I=?}
Set Analog Timing Properties	6.8.3	{:ANALOG#<in>@<S/A>I=<PHS>;<FHS>;<HS>;<VS>;<HP>;<VP>;}
Query Analog Timing Properties	6.8.4	{:ANALOG#<in>@<S/A>I=?}
Reset Analog Timing Properties	6.8.5	{:ANALOG#<in>@<S/A>I=RESET}

Operation	See in chapter	Command
Set Analog Color Properties	6.8.6	{:PICTURE#<in>@<S/A>I=<DF_CHA>;<DF_CHB>;<DF_CHC>;<G_CHA>;<G_CHB>;<G_CHC>;<O_CHA>;<O_CHB>;<O_CHC>;<CONT>;<SAT>;<BRIGHT>;<HUE>;}
Save Analog Color Properties	6.8.7	{:PICTURE#<in>@<S/A>I=SAVE}
Query Analog Color Properties	6.8.8	{:PICTURE#<in>@<S/A>I=?}
Reset Analog Color Properties	6.8.9	{:PICTURE#<in>@<S/A>I=FACTORY}
Set Analog Input Audio Parameters	6.8.10	{:AUDIN#<in>@<S/A>I=<VOL>;}
Query Analog Input Audio Properties	6.8.11	{:AUDIN#<in>@<S/A>I=?}
Set the No Sync Picture Properties	6.8.12	{:SETBG#<in>@<S/A>I=<RED>;<GREEN>;<BLUE>;<nss>}
Query the No Sync Picture Properties	6.8.13	{:SETBG#<in>@<S/A>I=?}
Query Timings of the Incoming Signal	6.8.14	{:GETTIMINGS#<in>@<S/A>I=?}
Save Preset	6.8.15	{:AF#<in>@SI=<IPS>}
Delete Preset	6.8.16	{:AF#<in>@SI=DEL;<PID>}
Delete All Presets	6.8.17	{:AF#<in>@SI=DEL;255}
Clone Preset	6.8.18	{:AF#<in>@SI=CL;<PID>}
List Presets	6.8.19	{:AF#<in>@<S/A>I=LIST}
Delete Preset from All Input Ports	6.8.20	{:AF#<in>@SI=DELALL;<PID>}

Output Properties

Operation	See in chapter	Command
Set Output Video Properties	6.9.1	{:HDMI#<out>@<S/A>O=<MODE>;<CSPAC>;<CRANG>;<SUBS>;<HDCP>;}
Query Output Video Properties	6.9.2	{:HDMI#<out>@<S/A>O=?}

7

Firmware Upgrade

This chapter is meant to help customers perform firmware upgrades on our products by giving a few tips on how to start and by explaining the features of the Lightware Device Updater (LDU) software. To get the latest software and firmware pack please contact support@lightware.eu.

▶ INSTALL AND UPGRADE

The transmitter can be upgraded by using Lightware Device Updater (LDU) software via USB. The application and the User's manual can be downloaded from www.lightware.eu.

ATTENTION! While the firmware is being upgraded, the normal operation mode is suspended as the switcher is switched to bootload mode. Signal processing is not performed. Do not interrupt the firmware upgrade. If any problem occurs, reboot the transmitter and restart the process.

ATTENTION! The firmware upgrade process has an effect on the configuration and the settings of the device. After the upgrading process, factory default settings will be loaded

Short Instructions

- Step 1.** Get the firmware pack and the Lightware Device Updater (LDU) application.
- Step 2.** Install the LDU application.
- Step 3.** Establish the connection between the computer and the device(s).
- Step 4.** Start the LDU and follow the instructions shown on the screen.

7.1. Install and Upgrade

Installation for Windows OS

INFO: The application can be installed under Windows XP or above.

Run the installer. If the User Account Control drops a pop-up message click **Yes**. During the installation you will be prompted to select the type of the installation:

Normal install	Snapshot install
Available for Windows and Mac OS X	Available for Windows
The installer can update only this instance	Cannot be updated
Only one updateable instance can exist for all users	More than one different version can be installed for all users

Comparison of install types

ATTENTION! Using the Normal install as the default value is highly recommended.

Installation for Mac OS X

INFO: After the installation, the Windows and the Mac application has the same look and functionality. This type of the installer is equal with the Normal install in case of Windows and results an updateable version with the same attributes.

Mount the DMG file with double clicking on it and drag the LDU icon over the Applications icon to copy the program into the Applications folder. If you want to copy the LDU into another location just drag the icon over the desired folder.

LDU Upgrade

- Step 1.** Run the application. In the welcome screen click on the  button in the top right corner; the About window will appear. Click on the **Check now** button. The program checks the available updates on Lightware website and shows its version.

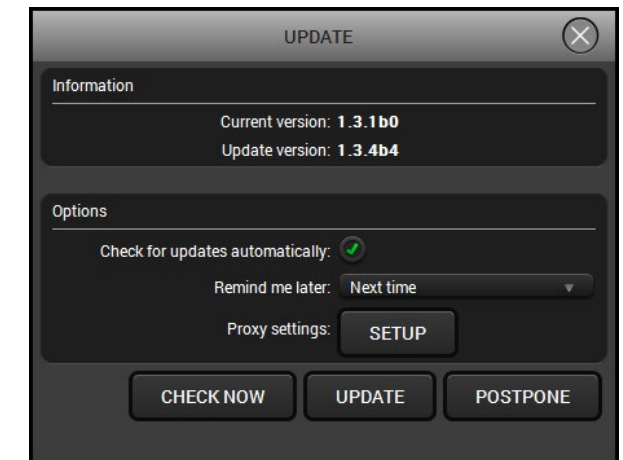

- Step 2.** Set the desired update settings in the **Options** section.

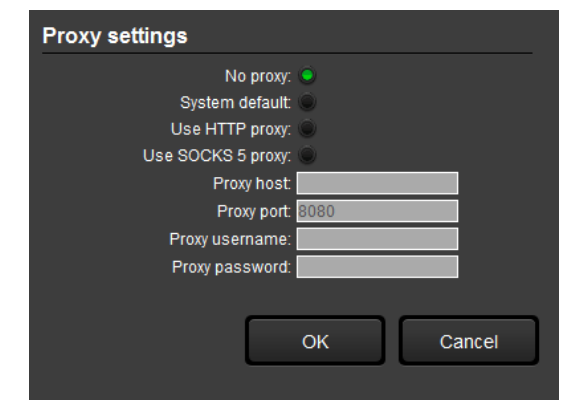

- If you do not want to check for the updates automatically, uncheck the **circle**, which contains the green tick.
- If you want to postpone the update, a reminder can be set with different delays from the **drop down list**.
- If the proxy settings traverse the update process, set the proper values then click the **OK** button.

Step 3. Press the **Update** button to download the new version; the installer will start.

7.1.1. Establish the Connection

Make sure that the computer and the device are connected via an USB and the connection is established between them.

7.1.2. Start the LDU and Follow the Instructions

After launching LDU the welcome screen will appear:

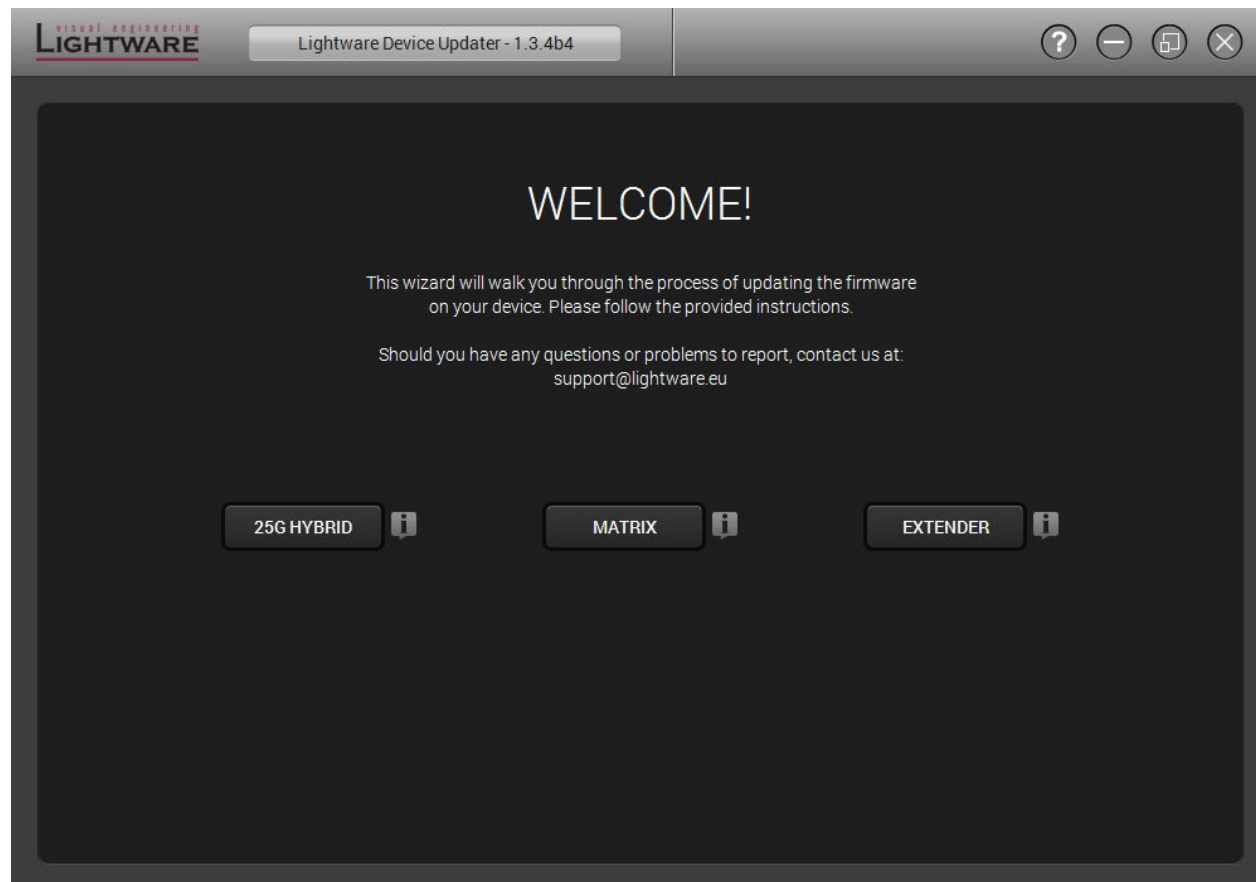

Pressing the **i** button a list will appear showing the supported devices.

Step 1. Click on the **Extender** button on the main screen.

Step 2. Select the package.

Click on the **Browse** button and select the “.lfp” file that will be used for the upgrade.

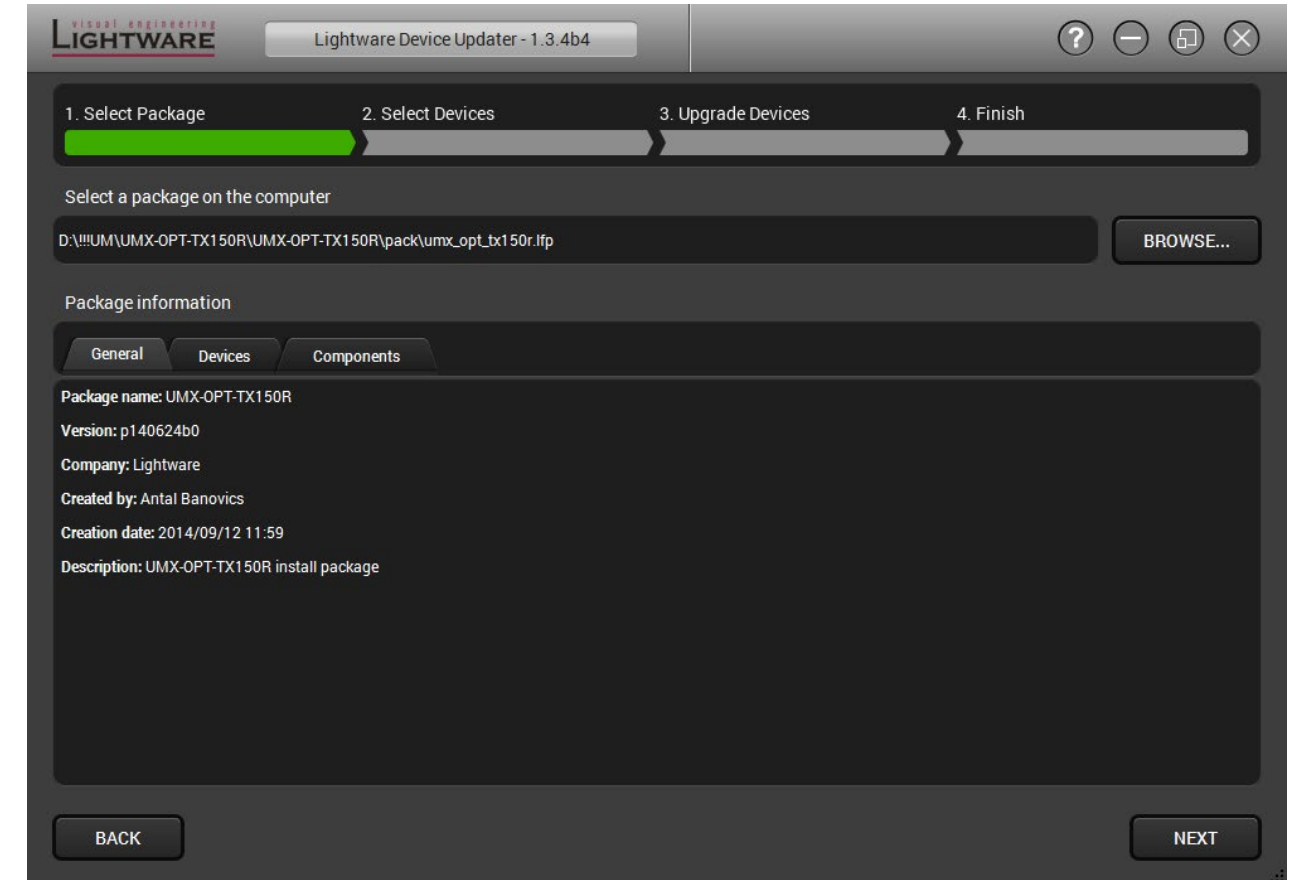

Package information is displayed:

- **General** version info, creation date, short description,
- **Devices** which are compatible with the firmware,
- **Components** in the package with release notes.

Step 3. Click on the **Next** button and follow the instructions.

TIPS AND TRICKS: Files with “.lfp” extension are associated to LDU during installation. If you double click on the “.lfp” file, the application is launched, the package is loaded automatically and above screen is shown.

Step 4. Select the device.

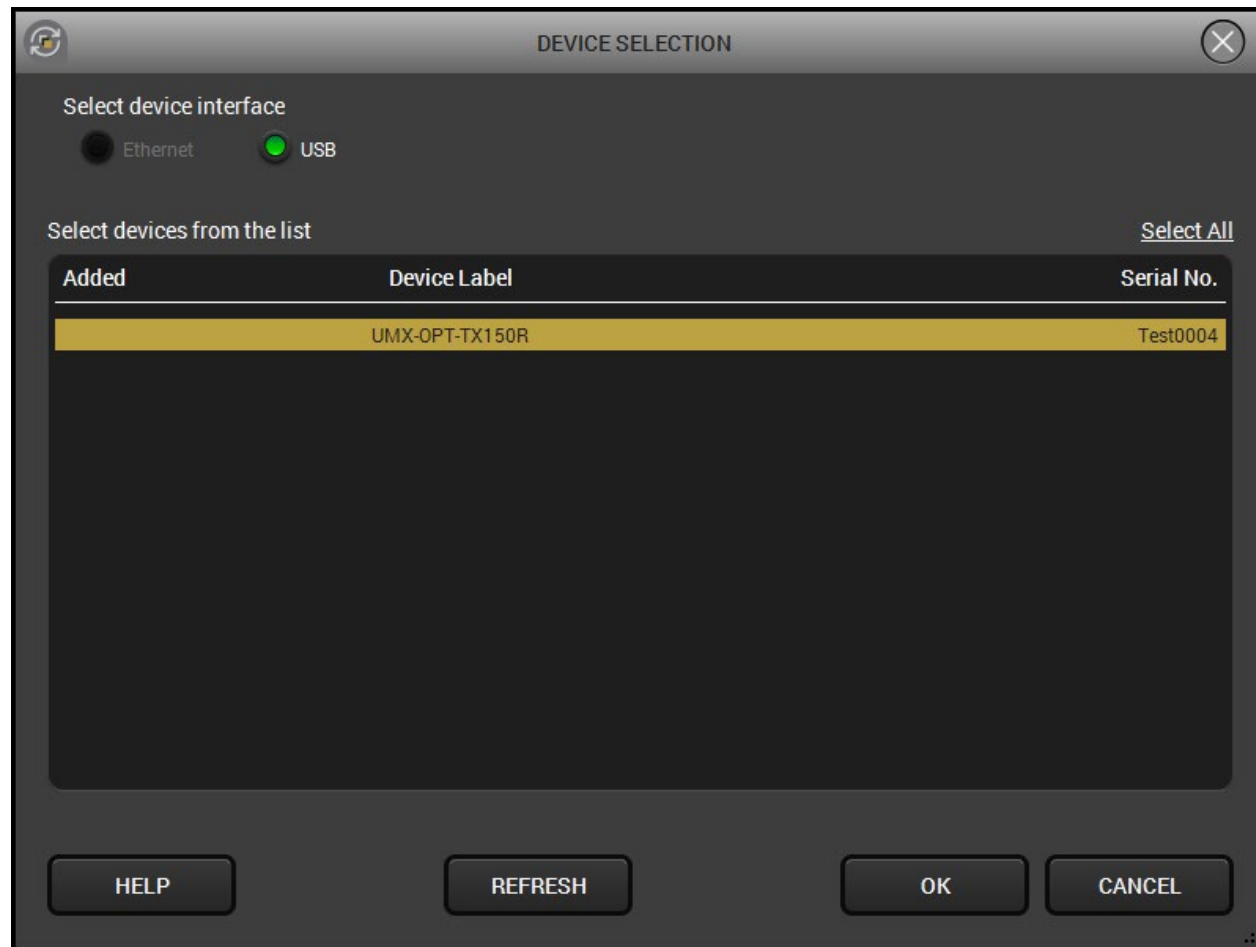

The following step is to select the desired device(s). The available and supported devices are searched and listed automatically. If the desired device is not listed, update the list by clicking the **Refresh** button. Select the desired devices: highlight them with a **yellow cursor**, then click **OK**.

A tick mark can be seen in the **Added** column if the device was added by the user previously.

Firmware Components

The firmware components of the selected devices are listed on the following screen: installed and update versions. (Update version will be uploaded to the device.)

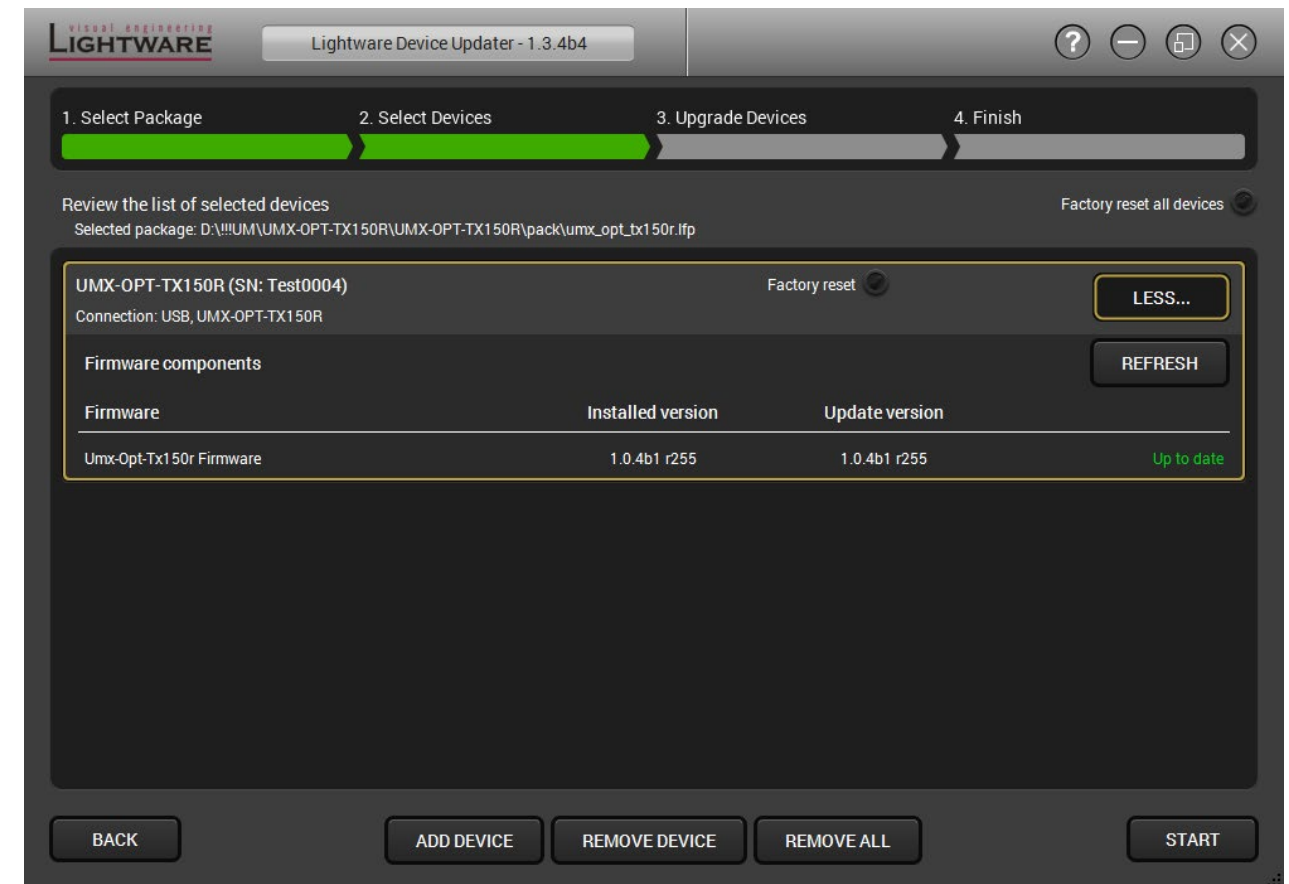

Add a device by clicking on the **Add device** button. The previous screen will be shown; select the desired device(s) and click on **OK**.

Remove a device by selecting it (highlight with yellow) and click on **Remove device** button, or click on **Remove all** button to empty the list.

Enabling **Factory reset** will perform factory default values for all settings in the device. Three different status can exist:

- **Enabled by user:** all settings will set to factory default values.
- **Disabled by user:** your settings will be saved and restored after upgrading.
- **Enabled by default and not changeable by user:** firmware upgrade must perform a factory reset to apply all changes coming with the new firmware version.

Click on the **Start** button to continue.

Step 5. Upgrade the device.

A warning window will pop up before starting upgrading the device:

- Do not unplug the power cable and the LAN cable while the upgrade is in progress. Click **OK** to continue.

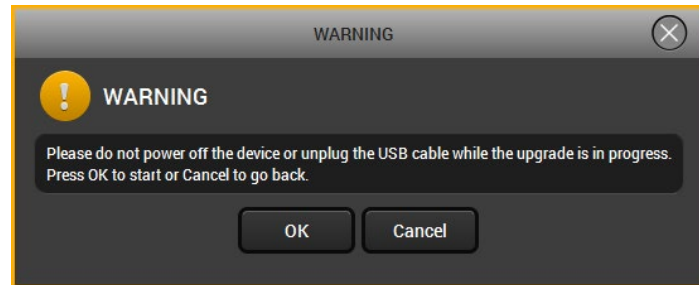

When you confirmed the warnings, the upgrade process starts automatically.

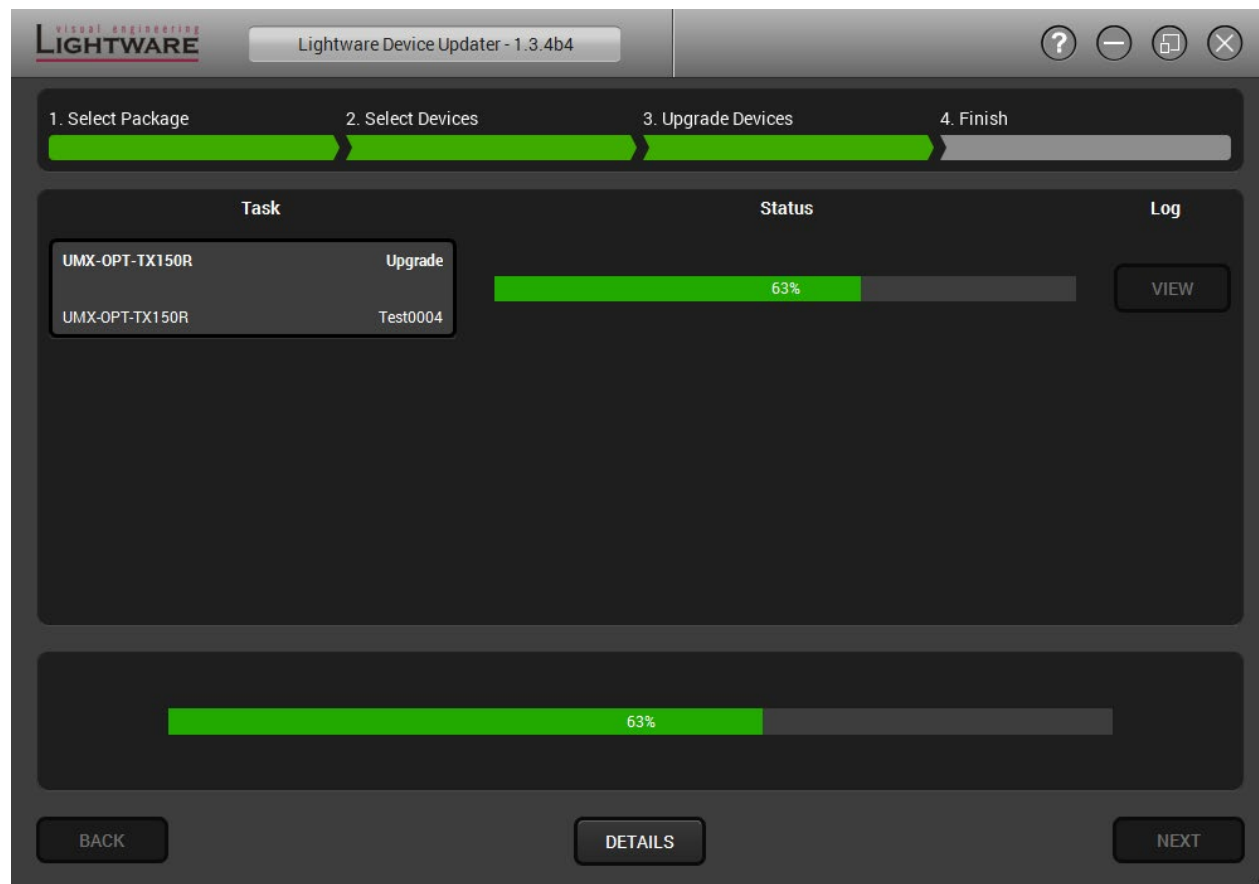

Details button opens a new window where the process is logged – see below.

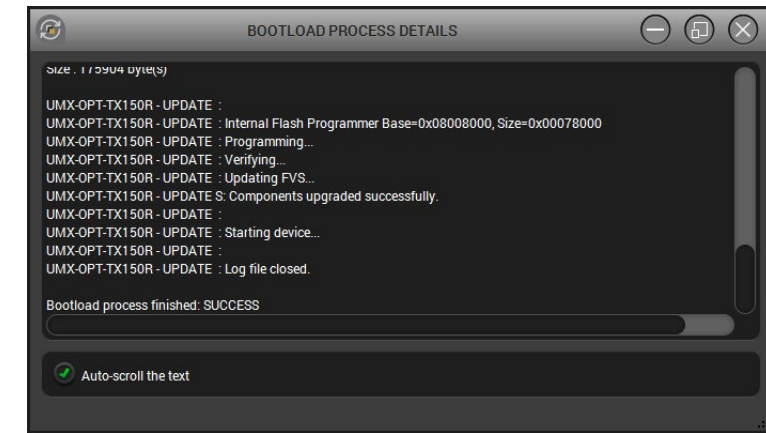
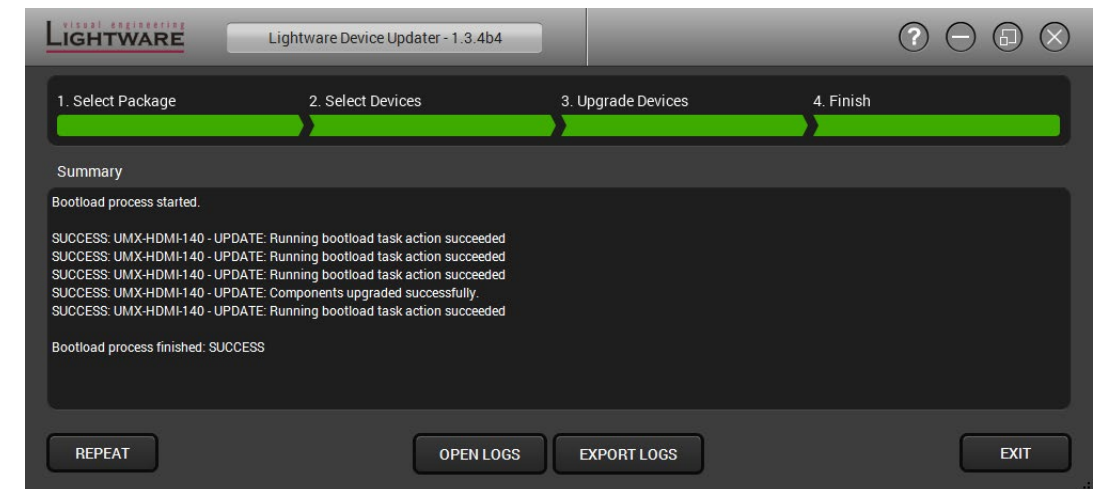
**Step 6.** Finish.

If the upgrade of a device is finished, the log can be opened by the View button on the right. When all the tasks are finished, a window appears. Click **OK** to close and **Next** to display the summary page.

Repeat button starts the process again with the selected device(s).

Open logs button opens the temporary folder where the logs can be found.

Export logs by saving the files as a zipped file.

Press **Exit** to close the program.

If the upgrade failed, the progress bar of the device is changed to red; restart the device(s) and repeat the process.

ATTENTION! However the device is rebooted after the firmware upgrade, switching it off and on again is recommended.

8





Troubleshooting













Usually, if the system seems not to transport the signal as expected, the best strategy for troubleshooting is to check signal integrity through the whole signal chain starting from source side and moving forward to switcher end.

General Problems – Check the Device

At first, check front panel LEDs and take the necessary steps according to their states. For more information about status, LEDs see [Front Panel LEDs](#) and [Rear Panel LEDs](#) section.

Pictogram Legend

-  Section to connections/cabling.
-  Section to front panel operation.
-  Section to LDC software.
-  Section to LW2 protocol commands.

Symptom	Root cause	Action	Refer to
Video signal			
No picture on the video output	Device(s) not powered properly	Check the extenders and the other devices if they are properly powered; try to unplug and reconnect them.	 3.3.9
	Cable connection problem	Due to the high data rates cables must fit very well, check all the connectors. If your source or display has more connectors then make sure that the proper input port is selected.	 3.3
	Cable quality problem	Due to the high data rates, high quality cables must be used. It is recommended to use OM3 or OM4 cables.	
	Endface surface of the fiber optical cable became contaminated.	Use special fiber optical cable cleaning equipment to clean it carefully.	
	Display is not capable of receiving the sent video Format.	Try emulating your display device's EDID to the source.	 4.7.5
			 5.6.1
	Not proper crosspoint setting	Check the connection between the inputs and the output port.	 5.3
	Source power and configuration problems	Check whether your source is powered on and configured properly. The HDMI output can be turned off on most DVD players. If the source is a computer, then verify that the VGA output is selected and active. Try restarting your computer; if you get a picture during the booting process, you have to review the driver settings.	
	Non HDCP compliant display	Many video sources send HDCP protected signal if they detect that the sink is HDCP capable – even if the content is not copyrighted. This can cause trouble if a HDCP capable device (for Example optical extender) is connected between the source and the display. In this case the content can't be viewed on non-HDCP capable displays. Disable HDCP function.	 4.8
			 5.4
HDCP is disabled	Enable HDCP on the input port.	 5.4	
Not the desired picture displayed on the video output	Video output is set to test pattern (no sync screen) as there is no picture on video source. Check video settings of the source.		
HDMI output signal contains no audio	HDMI mode was set to DVI	Check the properties of the output port and set to HDMI or Auto.	 5.5
	DVI EDID is emulated	Check the EDID and select and HDMI EDID to emulate.	 5.6
RS-232 signal			
	Cable connection problem	Check whether your serial cable is properly connected and check the wiring of the plugs.	 2.3.3
	RS-232 mode is not right	Check the RS-232 mode settings (pass or control)	 6.4.5

9

Technologies

The following sections contain descriptions and useful technical information how the devices work in the background. The content is based on experiences and cases we met in the practice. These sections help to understand features and technical standards like the followings:

- ▶ EDID MANAGEMENT
- ▶ HDCP MANAGEMENT
- ▶ PIXEL ACCURATE RECLOCKING

9.1. EDID Management

9.1.1. Understanding the EDID

The Extended Display Identification Data (EDID) is the passport of display devices (monitors, TV sets, projectors). It contains information about the capabilities of the display, such as supported resolutions, refresh rates (these are called Detailed Timings), the type and manufacturer of the display device, etc.

After connecting a source to a display (DVI, HDMI, DP), the source reads out the EDID to determine the resolution and refresh rate of the image to be transmitted.

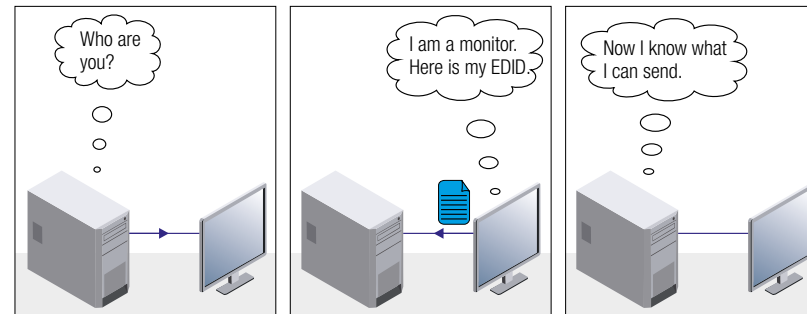

EDID Communication

Most DVI computer displays have 128-byte long EDID structure. However, Digital Televisions and HDMI capable displays may have another 128 bytes, which is called E-EDID and defined by CEA (Consumer Electronics Association). This extension contains information about additional Detailed Timings, audio capabilities, speaker allocation and HDMI capabilities. It is important to know that all HDMI capable devices must have CEA extension, but not all devices with CEA extension are HDMI capable.

Common Problems Related to EDID

Problem: “My system consists of the following: a computer, a Lightware device, a WUXGA (1920x1200) LCD monitor, and an SXGA (1280x1024) projector. I would like to see the same image on the monitor and the projector. What EDID should I choose on the Lightware device?”

Solution: If you want to see the image on both displays, you need to select the resolution of the smaller display (in this case SXGA), otherwise the smaller display may not show the higher resolution image.

Problem: “I have changed to a different EDID on an input port of the Lightware device to have a different resolution but nothing happens.”

Solution: Some graphics cards and video sources read out the EDID only after power-up and later they do not sense that EDID has been changed. You need to restart your source to make it read out the EDID again.

9.1.2. Advanced EDID Management

Each DVI sink (e.g. monitors, projectors, plasma displays, etc...) must support the EDID data structure. Source BIOS and operating systems are likely to query the sink using DDC2B protocol to determine what pixel Formats and interface are supported. DVI standard uses EDID data structure to identify the monitor type and capabilities. Most DVI sources (VGA cards, set top boxes, etc.) will output DVI signal after accepting the connected sink's EDID information. In the case of EDID readout failure or missing EDID, the source will not output DVI video signal.

Lightware devices provide the Advanced EDID Management function that helps system integration. The built-in EDID Router can store and emulate factory pre-programmed- and User programmable EDIDs. The EDID of the attached monitors or projectors for each output are stored in a non-volatile memory. This way the EDID of a monitor is available when the monitor is unplugged or switched off.

Any EDID can be emulated on any input. An emulated EDID can be copied from the EDID router's memory (static EDID emulation), or from the last attached monitor's memory (dynamic EDID emulation). For Example, the Lightware device can be set up to emulate a sink device, which is connected to one of the outputs. In this case, the EDID automatically changes, if the monitor is replaced with another display device (as long as it has a valid EDID).

EDID is independently programmable for all inputs without affecting each other. All inputs have their own EDID circuit.

INFO: The user is not required to disconnect the video cable to change an EDID as opposed to other manufacturer's products. EDID can be changed even if a source is connected to the input and powered ON.

INFO: When EDID has been changed, the router toggles the HOTPLUG signal for 2 seconds. Some sources do not sense this signal. In such cases, the source device must be restarted or powered OFF and ON again.

9.2. HDCP Management

Lightware Visual Engineering is a legal HDCP adopter. Several functions have been developed which helps to solve HDCP related problems. Complex AV systems often have both HDCP and non-HDCP components. The matrix allows transmitting HDCP encrypted and unencrypted signals. The devices will be still HDCP compliant as they will never output an encrypted signal to a non-HDCP compliant display device. If an encrypted signal is switched to a non-compliant output, a red screen alert or muted screen will appear.

9.2.1. Protected and Unprotected Content

Many video sources send HDCP protected signal if they detect that the sink is HDCP capable – even if the content is not copyrighted. This can cause trouble if an HDCP capable device is connected between the source and the display. In this case, the content cannot be viewed on non-HDCP capable displays and interfaces like event controllers. Rental and staging technicians often complain about certain laptops, which are always sending HDCP encrypted signals if the receiver device (display, matrix router, etc.) reports HDCP compliancy. However, HDCP encryption is not required all the time e.g. computer desktop image, certain laptops still do that.

To avoid unnecessary HDCP encryption, Lightware introduced the HDCP enabling/disabling function: the HDCP capability can be disabled in the Lightware device. If HDCP is disabled, the connected source will detect that the sink is not HDCP capable, and turn off authentication.

9.2.2. Disable Unnecessary Encryption

HDCP Compliant Sink

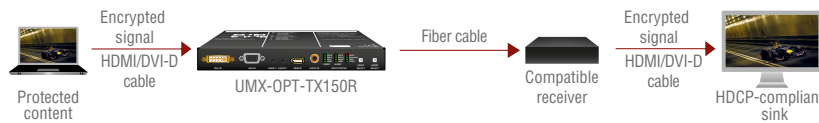

All the devices are HDCP-compliant, no manual setting is required, both protected and unprotected contents are transmitted and displayed on the sink.

Not HDCP-compliant Sink 1.

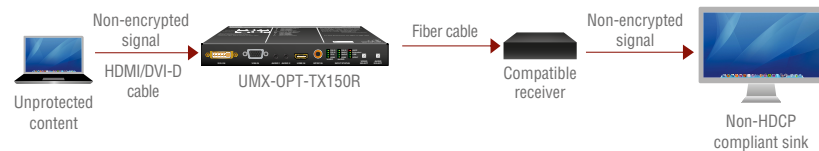

Not-HDCP compliant sink is connected to the matrix. Some sources (e.g. computers) always send HDCP encrypted signals if the receiver device reports HDCP compliancy, however, HDCP encryption is not required all the time (e.g. computer desktop image). If HDCP is enabled in the matrix, the image will not be displayed on the sink.

Setting the HDCP parameter to Auto on the output port and disable HDCP on the input port, the transmitted signal will not be encrypted if the content is not protected. Thus, non-HDCP compliant sinks will display non-encrypted signal.

Not HDCP-compliant Sink 2.

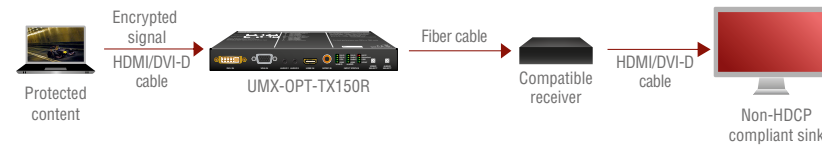

The layout is the same as in the previous case: non-HDCP compliant display device is connected to the matrix but the source would send protected content with encryption. If HDCP is enabled on the input port of the matrix, the source will send encrypted signal. The sink is not HDCP compliant, thus, it will not display the video signal (but blank/red/muted/etc. screen). If HDCP is disabled on the input port of the matrix, the source will not send the signal. The solution is to replace the display device to an HDCP-capable one.

9.3. Pixel Accurate Reclocking

Signal reclocking is an essential important procedure in digital signal transmission. After passing the reclocking circuit, the signal becomes stable, jitter-free, and can be transmitted over more equipment like processors, or event controllers. Without reclocking, sparkles, noise, and jaggies appear on the image.

Lightware’s sophisticated Pixel Accurate Reclocking technology fixes more problems than general TMDs reclocking. It removes not only intra-pair skew but inter-pair skew as well. The Pixel Accurate Reclocking circuit eliminates the following errors:

Intra-pair skew

Skew between the + and - wires within a differential wire pair (e.g. Data2- and Data2+). It’s caused by different wire lengths or slightly different wire construction (impedance mismatch) in DVI cable. It results in jitter.

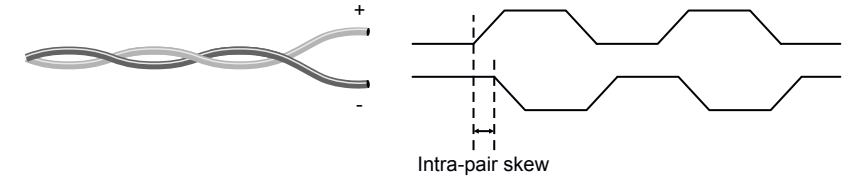

Inter-pair skew

Skew between two differential wire pairs in a cable. It is caused by different wire pair lengths or different number of twists in the DVI cable. Too much inter-pair skew results color shift in the picture or sync loss.

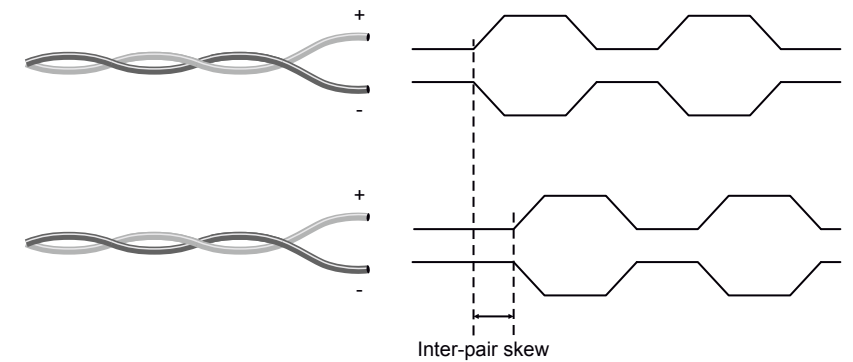

Jitter

Signal instability in the time domain. The time difference between two signal transitions should be a fixed value, but noise and other effects cause variations.

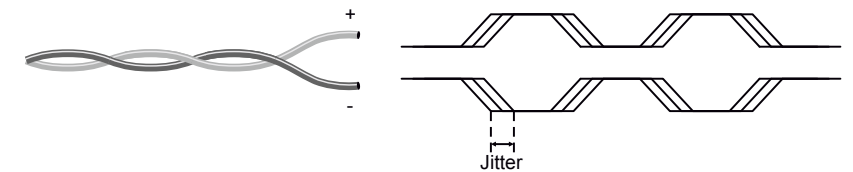

Noise

Electromagnetic interference between other electronic devices such as mobile phones, motors, etc. and the DVI cable are coupled onto the signal. Too much noise results in increased jitter.

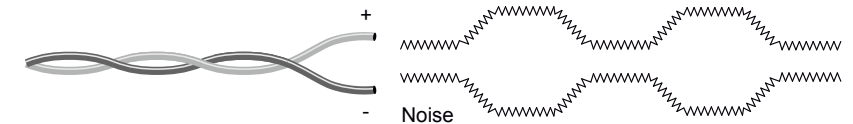

10

Appendix

Tables, drawings, and technical details as follows:

- ▶ [SPECIFICATION](#)
- ▶ [FACTORY DEFAULT SETTINGS](#)
- ▶ [FACTORY EDID LIST](#)
- ▶ [MECHANICAL DRAWINGS](#)
- ▶ [ASCII TABLE](#)
- ▶ [FURTHER INFORMATION](#)

10.1. Specification

General

Compliance	CE
EMC (Emission)	EN 55032:2015
EMC (Immunity)	EN 55024:2011
Warranty	3 years
Cooling.....	Passive
Operating temperature	0°C ~ +50°C (-4°F to +122°F)
Operating humidity	10 ~ 90% RH, non-condensing

Power

Power adaptor.....	External
Input.....	100-240 V AC 50/60 Hz
Output.....	+5V DC 2.5 A
Power consumption.....	3.5 W (typ.) / 5 W (max.)
Heat dissipation.....	11.9 BTU/h (typ.) / 17 BTU/h (max.)
Power connector.....	locking DC connector (2.5/5.5 mm)

Enclosure

Rack mountable	Yes
Material.....	1 mm steel
Dimensions in mm.....	221 W x 100.4 D x 26 H*
Dimensions in inch	8.70 W x 3.95 D x 1.02 H*
Net Weight.....	650 g

* Excluding connectors.

Control

Panel buttons	Yes, 4 buttons and 5 rotary switches
Serial port connector	DE-9F (9 pole D-SUB female for RS-232)
Available baud rates	9600, 19200, 38400, 57600 Baud
Default baud rate for control.....	57600 Baud, 8 bit, 1stop bit, no parity
USB port connector	Mini USB-B receptacle
Service menu.....	Yes

Audio and video inputs

HDMI input	19-pole HDMI Type A receptacle
Reclocking on HDMI input.....	Yes, Pixel Accurate Reclocking
DVI-I connector	29-pole, DVI-I digital and analog
Reclocking on DVI digital input	Yes, Pixel Accurate Reclocking
Input cable equalization	Yes, digital only, max 20 m
VGA (YPbPr or RGB) input.....	DE-15F (15-pole D-sub Female)
EDID emulation on video inputs.....	Yes, analog and digital
S/PDIF Digital audio input	RCA receptacle
Analog audio 1 input.....	3.5mm TRS connector (approx. 1/8" jack)
Analog audio 1 signal type.....	analog stereo, unbalanced
Analog audio 2 input.....	3.5mm TRS connector (approx. 1/8" jack)
Analog audio 2 signal type.....	analog stereo, unbalanced
EDID read from optical output	Yes, analog and digital

Optical output

Fiber	50/125 SC Multimode preferred or 62.5/125 SC Multimode
Laser wavelengths - high speed...	4ch. CWDM: 778; 800; 825; 850 nm
Laser wavelengths - low speed.....	2ch. CWDM: 911; 980 nm
Laser class specification.....	Class 3R
Transmitter output OMA*	-6.25 dBm (worst case)
Receiver OMA* sensitivity	-14.25 dBm (worst case)
Optical loss budget.....	8 dBm (worst case)
Transmission distance	2500 meters (using OM4 type fiber)

Digital video signal

Signal standardHDMI standard which supports:
 Deep color,
Embedded audio
Dolby TrueHD bitstream capable,
 Color depth..... maximum 36 bits, 12 bit/color
 Color Format RGB, YCbCr 4:4:4, xvYCC digital video
 Color space conversion..... Yes, always from any to RGB
 Maximum data rates.....6.75 Gbps (2.25 Gbps /TMDS channel)
 Maximum pixel clock.....225 MHz
 Video delay 0 frame
 Resolution .. all between 640x480 and 2048x1080@60 Hz deep color
 HDTV resolutions..... 720p, 1080i, 1080p
 Reclocking Pixel Accurate Reclocking
 EDID Support..... Advanced EDID management (analog and digital)
 EDID EmulationYes, 20 factory preset, 16 user programmable
 Output mode Automatic or manual (DVI or HDMI)
 HDCP compliant..... Yes

RGB input signal

RGB amplitude 0.7 Vp-p
 Impedance..... 75 Ω
 G.Sync..... 1.0 Vp-p
 Impedance..... 75 Ω
 H.Sync, V.Sync..... TTL high impedance, automatic pos/neg polarity
 Scanning frequency, H.Sync..... 15 ~ 100 kHz
 Scanning frequency, V.Sync 50 ~ 100 Hz

YPbPr input signal

Y (luminance) amplitude, including sync 1.0 Vp-p
 Impedance..... 75 Ω
 PbPr/CbCr (chroma) amplitude 0.7 Vp-p
 Impedance..... 75 Ω

H.Sync, V.Sync..... TTL high impedance, automatic pos/neg polarity
 Scanning frequency, H.Sync..... 15 ~ 100 kHz
 Scanning frequency, V.Sync 50 ~ 100 Hz

General analog audio signal

Overall system gain -1.3 dB
 Frequency response20 Hz – 0.45 fs (e.g. 21.6 kHz @ 48 kHz)
 S/N..... > 66 dB

Analog audio input

Impedance.....>10 kOhm
 Coupling mode.....AC (capacitive) coupled
 Nominal level..... 0 dBu
 Maximum level.....1VRMS (~2dBu)
 Input gain adjustment..... + 0 dB ... + 24 dB in 3 dB steps
 A/D resolution 24 bits
 A/D sample rate48 kHz, 96 kHz

10.2. Factory Default Settings

Parameter	Setting/Value
Video Port Settings	
Input port	DVI-D
HDCP	Enabled
No sync color	Enabled
No sync color	7F7F7F (grey)
Output video mode	Auto
Output HDCP mode	Auto
Video Auto Select	Enabled, NonPriority, First detect
Audio Auto Select	Enabled, First detect: Embedded, S/PDIF, Analog 2
RS-232 Settings	
Control protocol	LW2
Baud rate	57600
Data bits	8
Parity	No
Stop bits	1
Operation mode	Pass-through

10.3. Factory EDID List

INFO: Minor changes in the factory EDID list may be applied in further firmware versions.

The Emulated EDIDs on the video inputs can be chosen by rotary switches only:

Number on DVI-D EDID rotary	EDIDs for DVI-D Input	EDID reference in protocol
#0	Copy from SC MM OUT (Dynamic EDID)	D01
#1	Factory EDID Universal HDMI (default)	F01
#2	Factory EDID (DVI) 1024x768@60	F02
#3	Factory EDID (HDMI) 1280x720p@60	F03
#4	Factory EDID (HDMI) 1920x1080p@60	F04
#5	Factory EDID (DVI) 1920x1200@60	F05
#6	User EDID (def.: Univ. HDMI EDID)	U01
#7	User EDID (def.: Univ. HDMI EDID)	U02
#8	User EDID (def.: Univ. HDMI EDID)	U03
#9	User EDID (def.: Univ. HDMI EDID)	U04

Number on DVI-A EDID rotary	EDIDs for DVI-A Input	EDID reference in protocol
#0	Copy from SC MM OUT (Dynamic EDID)	D01
#1	Factory EDID Universal Analog (default)	F06
#2	Factory EDID (Analog) 1024x768@60	F07
#3	Factory EDID (Analog) 1280x720@60	F08
#4	Factory EDID (Analog) 1920x1080@60	F09
#5	Factory EDID (Analog) 1920x1200@60	F10
#6	User EDID (def.: Univ. Analog EDID)	U05
#7	User EDID (def.: Univ. Analog EDID)	U06
#8	User EDID (def.: Univ. Analog EDID)	U07
#9	User EDID (def.: Univ. Analog EDID)	U08

Number on VGA EDID rotary	EDIDs for VGA Input	EDID reference in protocol
#0	Copy from SC MM OUT (Dynamic EDID)	D01
#1	Factory EDID Universal Analog (default)	F11
#2	Factory EDID (Analog) 1024x768@60	F12
#3	Factory EDID (Analog) 1280x720@60	F13
#4	Factory EDID (Analog) 1920x1080@60	F14
#5	Factory EDID (Analog) 1920x1200@60	F15
#6	User EDID (def.: Univ. Analog EDID)	U09
#7	User EDID (def.: Univ. Analog EDID)	U10
#8	User EDID (def.: Univ. Analog EDID)	U11
#9	User EDID (def.: Univ. Analog EDID)	U12

Number on HDMI EDID rotary	EDIDs for HDMI Input	EDID reference in protocol
#0	Copy from SC MM OUT (Dynamic EDID)	D01
#1	Factory EDID Universal HDMI (default)	F16
#2	Factory EDID (DVI) 1024x768@60	F17
#3	Factory EDID (HDMI) 1280x720p@60	F18
#4	Factory EDID (HDMI) 1920x1080p@60	F19
#5	Factory EDID (DVI) 1920x1200@60	F20
#6	User EDID (def.: Univ. HDMI EDID)	U13
#7	User EDID (def.: Univ. HDMI EDID)	U14
#8	User EDID (def.: Univ. HDMI EDID)	U15
#9	User EDID (def.: Univ. HDMI EDID)	U16

10.4. Mechanical Drawings

The following drawings present the physical dimensions of the device. Dimensions are in mm.

Front View

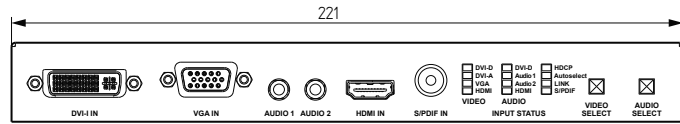

Rear View

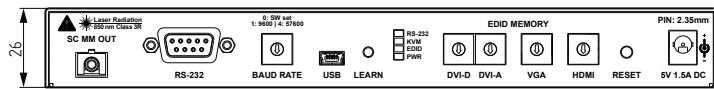

Top View

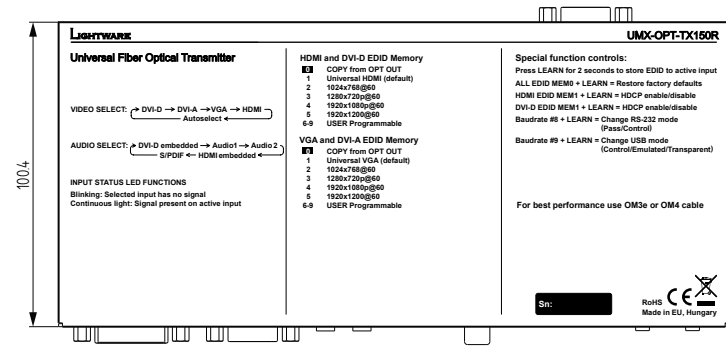

Bottom View

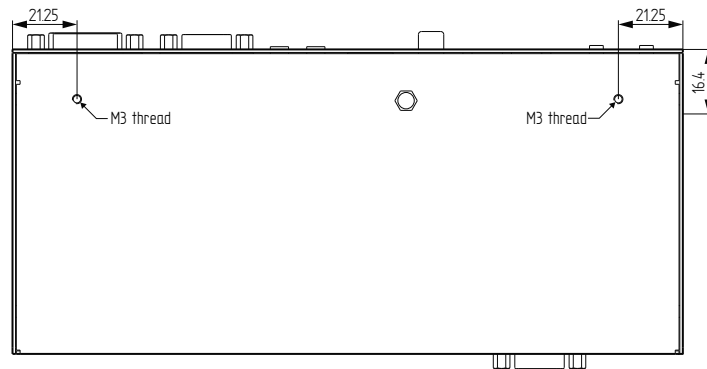

Left View

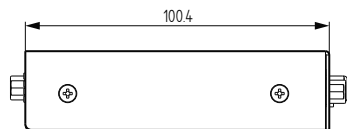

10.5. ASCII Table

The most frequently used characters are highlighted.

Dec	Hex	Char	Dec	Hex	Char	Dec	Hex	Char	Dec	Hex	Char
0	00	[NUL]	32	20	[Space]	64	40	@	96	60	`
1	01	[SOH]	33	21	!	65	41	A	97	61	a
2	02	[STX]	34	22	"	66	42	B	98	62	b
3	03	[ETX]	35	23	#	67	43	C	99	63	c
4	04	[EOT]	36	24	\$	68	44	D	100	64	d
5	05	[ENQ]	37	25	%	69	45	E	101	65	e
6	06	[ACK]	38	26	&	70	46	F	102	66	f
7	07	[BEL]	39	27	'	71	47	G	103	67	g
8	08	[BS]	40	28	(72	48	H	104	68	h
9	09	[TAB]	41	29)	73	49	I	105	69	i
10	0A	[LF]	42	2A	*	74	4A	J	106	6A	j
11	0B	[VT]	43	2B	+	75	4B	K	107	6B	k
12	0C	[FF]	44	2C	,	76	4C	L	108	6C	l
13	0D	[CR]	45	2D	-	77	4D	M	109	6D	m
14	0E	[SOH]	46	2E	.	78	4E	N	110	6E	n
15	0F	[SI]	47	2F	/	79	4F	O	111	6F	o
16	10	[DLE]	48	30	0	80	50	P	112	70	p
17	11	[DC1]	49	31	1	81	51	Q	113	71	q
18	12	[DC2]	50	32	2	82	52	R	114	72	r
19	13	[DC3]	51	33	3	83	53	S	115	73	s
20	14	[DC4]	52	34	4	84	54	T	116	74	t
21	15	[NAK]	53	35	5	85	55	U	117	75	u
22	16	[SYN]	54	36	6	86	56	V	118	76	v
23	17	[ETB]	55	37	7	87	57	W	119	77	w
24	18	[CAN]	56	38	8	88	58	X	120	78	x
25	19	[EM]	57	39	9	89	59	Y	121	79	y
26	1A	[SUB]	58	3A	:	90	5A	Z	122	7A	z
27	1B	[ESC]	59	3B	;	91	5B	[123	7B	{
28	1C	[FS]	60	3C	<	92	5C	\	124	7C	
29	1D	[GS]	61	3D	=	93	5D]	125	7D	}
30	1E	[RS]	62	3E	>	94	5E	^	126	7E	~
31	1F	[US]	63	3F	?	95	5F	_	127	7F	[DEL]

10.6. Further Information

Limited Warranty Statement

1. Lightware Visual Engineering LLC (Lightware) warrants to all trade and end user customers that any Lightware product purchased will be free from manufacturing defects in both material and workmanship for three (3) years from purchase unless stated otherwise below. The warranty period will begin on the latest possible date where proof of purchase/delivery can be provided by the customer. In the event that no proof can be provided (empty 'Date of purchase' field or a copy of invoice), the warranty period will begin from the point of delivery from Lightware.

1.1. 25G and MODEX product series will be subject to a seven (7) year warranty period under the same terms as outlined in this document.

1.2. If during the first three (3) months of purchase, the customer is unhappy with any aspect of a Lightware product, Lightware will accept a return for full credit.

1.3. Any product that fails in the first six (6) months of the warranty period will automatically be eligible for replacement and advanced replacement where available. Any replacements provided will be warranted for the remainder of the original unit's warranty period.

1.4. Product failures from six (6) months to the end of the warranty period will either be repaired or replaced at the discretion of Lightware. If Lightware chooses to replace the product then the replacement will be warranted for the remainder of the original unit's warranty period.

2. The above-stated warranty and procedures will not apply to any product that has been:

2.1. Modified, repaired or altered by anyone other than a certified Lightware engineer unless expressly agreed beforehand.

2.2. Used in any application other than that for which it was intended.

2.3. Subjected to any mechanical or electrical abuse or accidental damage.

2.4. Any costs incurred for repair/replacement of goods that fall into the above categories (2.1., 2.2., 2.3.) will be borne by the customer at a pre-agreed figure.

3. All products to be returned to Lightware require a return material authorization number (RMA) prior to shipment and this number must be clearly marked on the box. If an RMA number is not obtained or is not clearly marked on the box, Lightware will refuse the shipment.

3.1. The customer will be responsible for in-bound and Lightware will be responsible for out-bound shipping costs.

3.2. Newly repaired or replaced products will be warranted to the end of the originally purchased products warranty period.

Document Revision History

Rev.	Release date	Changes	Editor
1.0	10-09-2013	Initial version	Zsolt Markó
1.1	16-12-2015	Safety instructions updated, CE page pulled out	Laszlo Zsedenyi
2.0	16-06-2017	Restructure of the chapters (1-10), add technologies chapter, operation chapter, new flowcharts and description in video/audio input in autoselect mode, update Service Menu chapter, update Lightware Device Controller chapter, new Firmware Upgrade chapter, update the table of troubleshooting	Judit Barsony
3.0	01-09-2017	New document format	Judit Barsony

Contact Us

sales@lightware.com

+36 1 255 3800

support@lightware.com

+36 1 255 3810

Lightware Visual Engineering LLC.
Peterdy 15, Budapest H-1071, Hungary

www.lightware.com