



PROFESSIONAL AV SOLUTIONS
2015 Catalog

A MESSAGE FROM CHIEF

We've had a great year developing new solutions based directly on your feedback. Our customers' willingness to share their experiences and challenges from the field keep us creating new solutions to help with your AV needs.

Exhibit one from this year is the new ConnexSys™ Video Wall Mounting System. Every step of the development process was informed by feedback from customers familiar with video wall mounting solutions and what they like and dislike. Problems that kept repeating were alignment, speed, serviceability and rigidity. The design team used that feedback to determine how to best create a solution that provides features installers love – like channel strut installation, RapidDraw™ release, six points of adjustment in the PowerZone™ and rigidity to keep the placement stable.

Fusion® wall mounts, a hugely popular and appreciated mount, got a refresh through the feedback system of design thinking. Why touch a loved product? Because we always believe we can make it better. The enhanced mounts include better stability, exclusive nesting spacers, teardrop design installation for faster hanging, quick-store cords and simpler cable management options.

Another important project was the refresh of our Kontour™ monitor mounts. To make the series even better, we implemented changes based on customer feedback and added next generation Centris™ extreme tilt, easier fine-tuning, quick-release interfaces, improved bases with tool storage and more configurations and easier upgrade options. The array monitor mounts are also fully launched and ready to create ergonomic applications such as trading desks, call centers, IT, health care, control rooms and more.

Your feedback even helped us improve this catalog. We received a lot of great ideas that guided revisions and testing at every step along the way. For example, you wanted clearer information about accessory compatibility and an easier way to find product categories. We then created accessory pages next to the mounts they serve and clearly tabbed various categories for easier browsing.

Improvement never stops for us but we need to hear from you. Your comments and feedback push us to create better solutions to make your job easier. Thank you for all your insights and willingness to share them with us. For over 35 years we've been working hard to earn your support, and we hope you continue to push us into new levels of success for everyone.



Laurie Englert
Vice President of Marketing

Laurie Englert

A FOCUS *on* SUSTAINABILITY



At Chief, we embrace our commitment to sustainability and carry this philosophy into our product designs, business practices and facilities.

In recognition of these efforts, Chief received the 2013 Sustainable AV Award from InfoComm International®.

“A lot of companies talk about getting greener, but Milestone has transformed its words into action, and is a shining example of how exceptional companies can focus on improving the world, while at the same time producing world-class products,” said David Labuskes, CTS, RCDD, Executive Director and CEO, InfoComm International.



CONNECTING LEADING BRANDS YOUR FULL SERVICE AV PARTNER

Milestone AV Technologies is a leading designer and manufacturer of branded audiovisual products including flat panel mounting solutions, projector mounts, projection screens, equipment racks and furniture for AV markets. Milestone's innovative products are sold in the commercial markets under the Chief, Da-Lite and Projecta brand names, and in the consumer markets under the Sanus brand name. All brands work together to provide a breadth of product, strength of longevity, and advantage of superior customer service and support.

milestone™ AV Technologies

OUR COMMERCIAL BRANDS

CHIEF

Chief focuses on commercial AV flat panel and projector mounts. Home Theater, Workstation and Custom Display Solutions are also part of the Chief product offering. Known in the industry for high quality mounts with both Custom and Universal options, as well as an extensive accessories line, Chief is focused on professional installers worldwide.

DA-LITE

For over 100 years, Da-Lite has been designing, manufacturing and marketing the most comprehensive line of projection screens in the world. Today, we offer our widest selection ever of proprietary projection screen fabrics and materials in our history.

PROJECTA

As Europe's leading manufacturer of projection screens, Projecta offers top quality products, intelligent mounting systems and, of course, excellent dealer support. Projecta's strength lies in their primary focus on development and production, allowing them to offer advanced and durable projection screens and furniture to the market.



EARN *free* INDUSTRY CREDITS

with the Chief Certified Partner Program



More than 5,000 users have discovered the benefits of Chief's Certified Partner Program, and more than 2,600 of them have become Certified Partners. We love that so many of you continue to find our online training program valuable. The courses are taken at your own pace and cover a wide range of applications for installers and dealers.

We've added new modules like Education II and Digital Signage II, which features the ConnexSys Video Wall Mounting System. More courses are on the way soon.

As of Sept. 1, 2014, the program is worth up to 15.5 CTS RUs, 11.5 CEDIA CEUs and 6 DSEG Credits. We also send welcome gifts at 200 points and Visa gift cards at 600 and 1,200 points.

Visit certification.chiefmfg.com to check out the new training opportunities.



INDUSTRY CERTIFICATIONS

Chief is an Emerald Level Certified Audio Visual Solutions Provider (CAVSP) and our staff has achieved a published level of certification to maintain a standard of excellence in the AV industry.

- **Installer's Forum** - Certified through CEDIA, NSCA and InfoComm
- **RPA Mini Installer's Forum** - Certified through CEDIA
- **Safeguarding Your AV Investment** - Certified through CEDIA
- **AVIU, Ensuring a Secure Installation** - Accredited by CEDIA
- **Online Learning, Building Innovative AV Ceiling Installations** - Accredited by NSCA

AWARDS

CONNEXSYS VIDEO WALL MOUNTING SYSTEM

Digital Signage Magazine Best of Show - 2014

BEST SALES SUPPORT

SCN Stellar Service Awards - 2014

FAVORITE MOUNT MANUFACTURER

rAve Reader's Choice Award - 2014

FUSION CEILING MOUNTED VIDEO WALL SOLUTION

InAVation Award - 2013

INTERACTIVE CEILING MOUNTED PROJECTOR SOLUTION

InAVation Award - 2013

FUSION MANUAL HEIGHT ADJUSTABLE MOBILE CART

Installation Product Award - 2013

FUSION VIDEO WALL CEILING MOUNT & FUSION VIDEO WALL BOLT-DOWN MOUNT

Innovation Award - Sound & Video Contractor - 2013

MILESTONE AV TECHNOLOGIES

InfoComm Sustainable Technology Award - 2013



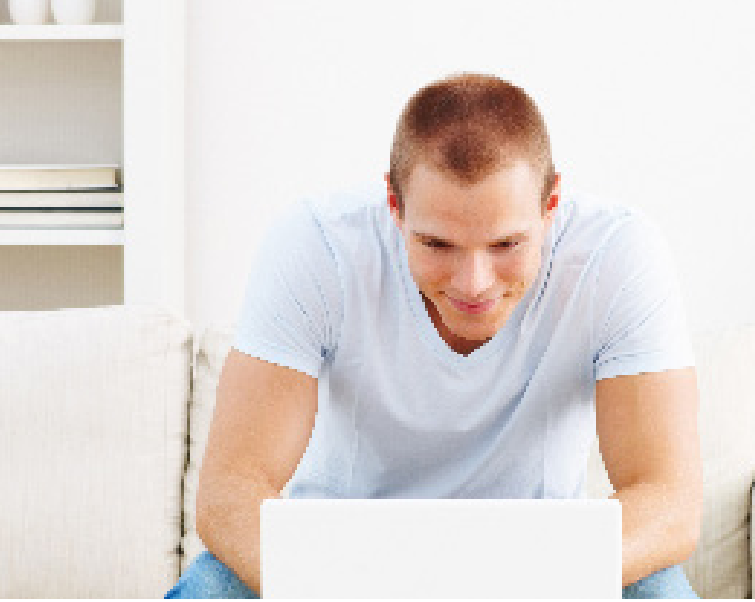

ONLINE TOOLS

In our continuing effort to be the easiest manufacturing partner to work with, Chief has a host of online tools and resources to make your next project as easy as possible.

RACKBUILDER™

RackBuilder is Chief's intuitive web application for visually configuring rack solutions with an extensive library of accessories and third party components.

rackbuilder.chiefmfg.com

CERTIFIED PARTNER PROGRAM

Thousands of professionals have been using Chief's Certified Partner Program to differentiate their businesses and earn free industry credits in the process. This year, we've introduced an improved login and registration process, the ability to instantly download your training transcripts and a streamlined rewards program with great incentives for training with us, among other updates.

certification.chiefmfg.com

VIDEOS & ANIMATIONS

Learn about our product features and how easy they are to install. View our videos or download them to look at later. They can also be embedded into your presentations or easily forwarded to coworkers.

chiefmfg.com/Videos

CHIEF IMAGE LIBRARY

Get all the product shots, application photos and videos you need for your website and marketing collateral on Chief's new Image Library. Register online to gain access!

milestone.tandemvault.com

DESIGN CENTER

Chief's Design Center is our resource for Architects, Consultants and Designers. Chief also provides architects and designers with relevant downloadable documentation for many products - BIM Objects, CAD drawings, tech drawings and manuals. The documents can be found on the downloads tab of all our product pages.

chiefmfg.com/Design

FAST-FLIP CATALOG

The Fast-Flip Catalog is the online version of the catalog, which has many of benefits - you can access it from anywhere, you can view linked videos for specific products, and you can instantaneously get to the page you need with navigational links.

chiefmfg.com/FastFlip

LITERATURE DOWNLOADS

Find product lines, brochures, new product flyers, whitepapers and application-focused solutions on the Chief literature page, where you can download, print or request copies.

chiefmfg.com/Literature

VERTICAL MARKETS PAGES

See the application drop down menu on the Chief page for market specific information and solutions.

www.chiefmfg.com (application drop-down)

THROW DISTANCE CALCULATOR

Choose from an extensive lists of projectors and adjust room lighting, screen gain, application and diagonal to find the optimum distance for top performance.

chiefmfg.com/ProjectorCalculator

MULTI-MONITOR CALCULATOR

Enter in the number of screens, their size and mounting patterns, and the multi-monitor calculator will help you determine which mount will best serve your needs.

chiefmfg.com/MonitorCalculator

VIDEO CONFERENCING ACCESSORY FINDER

Quickly determine the range of Chief accessories that help customize common video conferencing products.

chiefmfg.com/VideoConferenceCalculator

AUTOMATED PRODUCT SERIAL COMMAND CALCULATOR

Find serial commands for Chief's automated solutions by selecting a product and address.

chiefmfg.com/AutomatedRemoteCodes



TABLE OF CONTENTS

QUICK REFERENCE CHARTS

6 - 7 Projector Mounts

7 - 9 Wall Display Mounts

9 - 11 Ceiling Display Mounts

11 - 13 Freestanding Display Mounts

13 - 16 Monitor Mounts

17 Rack Systems

PROJECTOR MOUNTS

18 - 20 RPE Elite® Ceiling Projector Mounts

21 RPEU® Series Ceiling Projector Mounts

22 Other Ceiling Projector Mounts

23 - 25 Ceiling Projector Mount Accessories

26 - 28 Automated Projector Mounts & Accessories

29 - 32 WM Series Short Throw Projector Mounts & Accessories

34 WP2 Series Short Throw Projector Mounts & Accessories

35 Integrated Interactive System & Accessories

WALL DISPLAY MOUNTS

36 - 40 Fusion® Fixed Display Wall Mounts & Accessories

41 Thinstall™ Fixed Display Wall Mounts & Accessories

42 Other Fixed Display Wall Mounts & Accessories

43 - 47 Fusion Tilt Display Wall Mounts & Accessories

46 Thinstall Tilt Display Wall Mounts & Accessories

49 Other Tilt Display Wall Mounts & Accessories

50 - 51 ConnexSys™ Video Wall TV System

52 - 54 Fusion Pull-Out Mounts & Accessories

55 - 58 Thinstall Swing Arm Display Wall Mounts & Accessories

59 Other Swing Arm Display Wall Mounts & Accessories

CEILING DISPLAY MOUNTS

60 - 62 Fusion Video Wall Display Ceiling Mounts

63 - 65 Fusion Menu Board Display Ceiling Mounts

66 - 74 Fusion Ceiling Mounts & Accessories

75 Automated Ceiling Lift

76 - 77 Other Ceiling Truss & Pole Mounts & Accessories

TABLE OF CONTENTS

FREESTANDING DISPLAY MOUNTS

- | | |
|--|--|
| 78 - 83 Fusion Video Wall Freestanding Display Mounts & Accessories | 89 - 91 Other Cart & Stand Display Mounts & Accessories |
| 84 - 87 Fusion Carts, Stands & Accessories | 92 Table Stand Display Mounts & Accessories |
| 88 Automated Pop-Up Lift | |

MONITOR MOUNTS



























- | | |
|---|---|
| 93 - 97 Kontour™ K1 Desk Monitor Mounts & Accessories | 114 Other Wall Monitor Mounts |
| 98 - 100 Kontour K2 Desk Monitor Mounts & Accessories | 115 - 116 Kontour K4 Wall Monitor Mounts |
| 101 - 104 Kontour K3 Desk Array Monitor Mounts & Accessories | 117 - 119 Kontour K1 Pole Monitor Mounts & Accessories |
| 105 - 108 Kontour K4 Desk Array Monitor Mounts & Accessories | 120 - 122 Kontour K2 Pole Monitor Mounts & Accessories |
| 109 - 111 Kontour K1 Wall Monitor Mounts & Accessories | 122 Other Pole Monitor Mount |
| 112 - 114 Kontour K2 Wall Monitor Mounts & Accessories | 123 - 125 Tablet Mounts |



RACK SYSTEMS

- | | |
|---|---|
| 126 RackBuilder™ Online Tools | 134 - 136 Raxxess Rotating & Pull-Out Rack Systems & Accessories |
| 127 - 128 Raxxess™ Knock Down Rack Systems & Accessories | 137 Raxxess On-Wall Rack Systems & Accessories |
| 129 - 130 Raxxess Gangable Rack Systems & Accessories | 138 - 139 Raxxess Freestanding Rack Systems & Accessories |
| 131 - 132 Raxxess Enclosed Rack Systems & Accessories | 140 - 143 Other Raxxess Rack Accessories |
| 133 Raxxess Furniture Rack Systems | |

QUICK REFERENCE CHART

 = QUALIFIES FOR LEED CREDIT

CEILING PROJECTOR MOUNTS						
Model	Product	Weight Capacity	Roll, Pitch, and Yaw	Dimensions (HxWxD)	Color	Page
KITEC030045		11.3 kg	3°, 15°, 360°	Various	 	19
KITEC045080		11.3 kg	3°, 15°, 360°	Various	 	19
KITEC080135		11.3 kg	3°, 15°, 360°	Various	 	19
RPMEU RPE ELITE® SERIES		22.7 kg	3°, 20°, 360°	69 x 165 x 140 mm	 	20
RSMEU RPE ELITE SERIES		11.3 kg	3°, 15°, 360°	46 x 111 x 129 mm	 	20
RPEU RPE SERIES	 	22.7 kg	4°, 25°, 360°	44 x 165 x 140 mm	 	21
RSEU RPE SERIES	 	11.3 kg	3°, 20°, 360°	37 x 111 x 112 mm	 	21
VCMEU		113.4 kg	5°, 20°, 360°	97 x 432 x 235 mm		22
KITMZ006S		11.3 kg	3°, 15°, 360°	Various		22













AUTOMATED PROJECTOR MOUNTS							
Model	Product	Extension	Weight Capacity	Max Projector Size (HxWxD)	Ceiling Opening (HxWxD)	Ceiling Closure (WxD)	Page
SL220 SMART-LIFT		216 mm	13.6 kg	241 x 419 x 470 mm	284 x 597 x 597 mm	489 x 526 mm	27
SL236i SMART-LIFT		914 mm	15.9 kg	235 x 521 x 578 mm	282 x 648 x 724 mm	607 x 607 mm	27
SL151i SMART-LIFT		211 mm	15.9 kg	213 x 464 x 464 mm	284 x 597 x 597 mm	514 x 515 mm	27

WALL PROJECTOR MOUNTS							
Model	Product	Extension	Weight Capacity	Pitch	Lateral Shift	Dimensions (HxWxD)	Page
WM210AUS WM SERIES		 EXTENDS UP TO 495 mm	11.3 kg	±3°	330 mm	293 x 499 x 586 mm	30
WM220AUS WM SERIES		 EXTENDS UP TO 768 mm	11.3 kg	±3°	330 mm	293 x 499 x 904 mm	30
WM230AUS WM SERIES		 EXTENDS UP TO 1,384 mm	11.3 kg	±3°	330 mm	29 x 50 x 151 cm	30
WM110AUS WM SERIES		 EXTENDS UP TO 457 mm	11.3 kg	±3°	N/A	360 x 185 x 551 mm	31

QUICK REFERENCE CHART

 = QUALIFIES FOR LEED CREDIT



WALL PROJECTOR MOUNTS							
Model	Product	Extension	Weight Capacity	Pitch	Lateral Shift	Dimensions (HxWxD)	Page
WM120AUS WM SERIES		M EXTENDS UP TO 724 mm	11.3 kg	±3°	N/A	360 x 185 x 869 mm	31
WM130AUS WM SERIES		L EXTENDS UP TO 1,334 cm	11.3 kg	±3°	N/A	360 x 185 x 1479 mm	31
WP21US WPSERIES		S EXTENDS UP TO 562 mm	11.3 kg	±3°	44 mm	22 x 48 x 62 cm	33
WP22US WPSERIES		M EXTENDS UP TO 968 mm	11.3 kg	±3°	44 mm	22 x 48 x 103 cm	33
WP23US WPSERIES		L EXTENDS UP TO 1,375 cm	11.3 kg	±3°	44 mm	22 x 48 x 143 cm	33
WMA1S WALL MOUNT ACCESSORY		S EXTENDS UP TO 495 mm	Concrete/Wood 68 kg Steel Stud 22.7 kg	N/A	N/A	361 x 185 x 292 mm	33
WMA2S WALL MOUNT ACCESSORY		M EXTENDS UP TO 533 mm	Concrete/Wood 68 kg Steel Stud 22.7 kg	N/A	N/A	292 x 470 x 330 mm	34
AN2 INTERACTIVE SYSTEM		N/A	11.3 kg	N/A	N/A	Depends on model	35

FIXED DISPLAY WALL MOUNTS									
Model	Product	Screen Size	Weight Capacity	Dimensions (HxWxD)	Mounting Patterns (W,H)	Max Lateral Shift	Height Adjust	Page	
XSM1U FUSION™ SERIES	 	XL 55 - 90"	113.4 kg	667 x 1086 x 57 mm	200 x 200 - 1086 x 600	426 mm	25 mm	37	
LSM1U FUSION SERIES	 	L 37 - 80"	90.7 kg	464 x 883 x 51 mm	100 x 100 - 881 x 400	426 mm	25 mm	37	
LSA1U FUSION SERIES	 	L 37 - 80"	90.7 kg	455 x 883 x 51 mm	100 x 100 - 876 x 400	390 mm	N/A	37	
MSM1U FUSION SERIES	 	M 26 - 47"	56.7 kg	464 x 654 x 51 mm	100x 100 - 653 x 400	198 mm	25 mm	38	
MSA1U FUSION SERIES	 	M 26 - 47"	56.7 kg	455 x 654 x 51 mm	100 x 100 - 647 x 400	161 mm	N/A	38	
LSTU THINSTALL™ SERIES		L 37 - 63"	56.7 kg	628 x 907 x 10 mm	200 x 200 mm - 800 x 500 mm	N/A	N/A	41	
MSTU THINSTALL SERIES		M 26 - 47"	56.7 kg	530 x 706 x 10 mm	100 x 100 mm - 600 x 400 mm	N/A	N/A	41	
PSMH MULTIPLE MODELS		XL 60 - 108"	136 kg	635 x 924 x 74 mm	400 x 400 mm - 800 x 400 mm	N/A	N/A	42	







QUICK REFERENCE CHART

 = QUALIFIES FOR LEED CREDIT



























FIXED DISPLAY WALL MOUNTS								
Model	Product	Screen Size	Weight Capacity	Dimensions (HxWxD)	Mounting Patterns (W,H)	Max Lateral Shift	Height Adjust	Page
FSRV		S 10 - 32"	20.4 kg	178 x 152 x 19 mm	75 x 75 mm, - 200 x 100 mm	N/A	N/A	42
PAC101		N/A	9.1 kg	55 x 356 x 264 mm	N/A	N/A	N/A	42











TILT DISPLAY WALL MOUNTS								
Model	Product	Screen Size	Weight Capacity	Dimensions (HxWxD)	Mounting Patterns (W,H)	Max Lateral Shift	Tilt	Page
XTMIU FUSION™ SERIES	 	XL 55 - 90"	113.4 kg	68.6 x 123.4 x 5.1 cm	622 x 1086 x 64 mm	542 mm	+5°, -12°	44
LTM1U FUSION SERIES	 	L 37 - 80"	90.7 kg	432 x 883 x 51 mm	100 x 100 mm - 895 x 505 mm	441 mm	+2°, -12°	44
LTA1U FUSION SERIES	 	L 37 - 80"	90.9 kg	419 x 883 x 50.8 mm	100 x 100 mm - 895 x 505 mm	441 mm	+2°, -12°	44
MTM1U FUSION SERIES	 	M 26 - 55"	56.7 kg	432 x 654 x 51 mm	100 x 100 mm - 667 x 400 mm	327 mm	+2°, -12°	45
MTMPIU FUSION SERIES	 	M 26 - 55"	56.7 kg	622 x 530 x 81 mm	100 x 100 mm - 600 x 460 mm	265 mm	+5°, -12°	45
MTA1U FUSION SERIES	 	M 26 - 55"	56.7 kg	419 x 654 x 51 mm	100 x 100 mm - 673 x 400 mm	327 mm	+2°, -12°	45
LTTU THINSTALL™ SERIES		L 37 - 80"	45.4 kg	548 x 907 x 19 mm	200 x 200 mm - 800 x 500 mm	N/A	-12°	48
MTTU THINSTALL SERIES		M 26 - 55"	45.4 kg	448 x 706 x 19 mm	100 x 100 mm - 600 x 400 mm	N/A	-12°	48
MWCU		M 26 - 55"	45.4 kg	303 x 487 x 114 mm	100 x 100 mm - 709 x 431 mm	N/A	-15°	49
FTRV		S 10 - 32"	20.4 kg	142 x 141 x 46 mm	75 x 75 mm - 200 x 100 mm	N/A	+5°, -15°	49

MULTI-DISPLAY WALL MOUNTS									
Model	Product	Screen Size	Weight Capacity (per screen)	Dimensions (HxWxD)	Mounting Patterns (WxH)	Tilt	Height Adjust	Total Depth Adjust	Page
LVS1U CONNEXSYS™ SERIES		L 42 - 80"	68 kg	485 x 903 x 102 mm	200 x 200 - 700 x 400 mm	+4°/-2.5°	± 25 mm	85 mm	51
LVS1UP CONNEXSYS SERIES		L 40 - 80"	68 kg	825 x 496 x 104 mm	200 x 200 - 800 x 400 mm	+4°/-2.5°	± 25 mm	85 mm	51
LVSXU CONNEXSYS SERIES		L 42 - 80"	68 kg	485 x 903 x 102 mm	200 x 200 - 700 x 400 mm	+4°/-2.5°	± 25 mm	85 mm	51
LVSXUP CONNEXSYS SERIES		L 40 - 80"	68 kg	825 x 496 x 104 mm	200 x 200 - 800 x 400 mm	+4°/-2.5°	± 25 mm	85 mm	51

QUICK REFERENCE CHART

 = QUALIFIES FOR LEED CREDIT

















SWING ARM DISPLAY WALL MOUNTS								
Model	Product	Screen Size	Weight Capacity (per screen)	Dimensions (HxWxD)	Mounting Patterns (W,H)	Max Lateral Shift	Extension	Page
LSMVU FUSION [®] SERIES		 37 - 63"	68 kg	533 x 879 x 94 mm	200 x 200 mm - 760 x 505 mm	445 mm	272 mm	52
LSMVPV FUSION SERIES		 37 - 63"	68 kg	826 x 523 x 94 mm	200 x 200 mm - 800 x 400 mm	102 mm	272 mm	52
MSMVU FUSION SERIES		 26 - 47"	56.7 kg	419 x 648 x 94 mm	100 x 100 mm - 540 x 400 mm	368 mm	272 mm	53
MSMVPV FUSION SERIES		 26 - 47"	56.7 kg	620 x 523 x 94 mm	100 x 100 mm - 600 x 400 mm	254 mm	272 mm	53
TS525TU THININSTALL [™] SERIES		 37 - 58"	56.7 kg	527 x 749 x 38 mm	100 x 100 mm - 800 x 400 mm	635 mm	406 mm	56
TS325TU THININSTALL SERIES		 26 - 52"	34 kg	439 x 749 x 46 mm	100 x 100 mm - 600 x 400 mm	635 mm	406 mm	56
TS318TU THININSTALL SERIES		 26 - 52"	34 kg	439 x 574 x 46 mm	100 x 100 mm - 600 x 400 mm	457 mm	406 mm	56
TS318SU THININSTALL SERIES		 26 - 52"	34 kg	343 x 574 x 46 mm	100 x 100 mm - 600 x 400 mm	457 mm	N/A	56
TS218SU THININSTALL SERIES		 26 - 47"	34 kg	356 x 330 x 38 mm	100 x 100 mm - 400 x 400 mm	457 mm	N/A	57
TS118SU THININSTALL SERIES		 10 - 32"	15.9 kg	294 x 330 x 38 mm	75 x 75 mm - 200 x 200 mm	457 mm	N/A	57
TS110SU THININSTALL SERIES		 10 - 32"	15.9 kg	239 x 356 x 38 mm	75 x 75 mm - 200 x 200 mm	250 mm	N/A	57
PDRUB		 42 - 80"	90.7 kg	560 x 1003 x 86 mm	200 x 200 mm - 862 x 517 mm	940 mm	229 mm	59
PNRUB		 42 - 80"	90.7 kg	538 x 687 x 84 mm	200 x 200 mm - 862 x 517 mm	635 mm	229 mm	59





















VIDEO WALL DISPLAY CEILING MOUNTS							
Model	Product	Screen Size	Configuration	Weight Capacity (per screen)	Dimensions (HxWxD)	Mounting Patterns (W,H)	Page
LCM3X3U FUSION SERIES		 40 - 55"	3 wide x 3 tall Landscape	38.5 kg	199.6 x 276.3 x 36.8 cm	Any Width x 100 - 400 mm	61
LCM3X2U FUSION SERIES		 40 - 55"	3 wide x 2 tall Landscape	56.7 kg	138.9 x 276.6 x 36.8 cm	Any Width x 100 - 400 mm	61
LCM3X2UP FUSION SERIES		 40 - 55"	3 wide x 2 tall Portrait	56.7 kg	199.6 x 174.8 x 36.8 cm	Any Width x 100 - 400 mm	61
LCM2X2U FUSION SERIES		 40 - 55"	2 wide x 2 tall Landscape	56.7 kg	138.9 x 185.1 x 36.8 cm	Any Width x 100 - 400 mm	62
LCM2X2UP FUSION SERIES		 40 - 55"	2 wide x 2 tall Portrait	56.7 kg	199.6 x 118.9 x 36.8 cm	Any Width x 100 - 400 mm	62



QUICK REFERENCE CHART



































 = QUALIFIES FOR LEED CREDIT

MENU BOARD DISPLAY CEILING MOUNTS								
Model	Product	Screen Size	Configuration	Weight Capacity (per screen)	Dimensions (HxWxD)	Mounting Patterns (W,H)	Micro Height Adjust	Page
LCM3X1U FUSION [™] SERIES		 40 - 55"	3 wide Landscape	56.7 kg	42.5 x 276.6 x 20.1 cm	Any Width x 100 - 400 mm	51 mm	63
LCM3X1UP FUSION [™] SERIES		 40 - 55"	3 wide Portrait	56.7 kg	82.6 x 175 x 20.1 mm	Any Width x 100 - 800 mm	51 mm	63
LCB3X1U FUSION [™] SERIES		 40 - 55"	3 wide Back-to-Back Landscape	56.7 kg	42.5 x 276.3 x 29.2 cm	Any Width x 100 - 400 mm	51 mm	64
LCB3X1UP FUSION [™] SERIES		 40 - 55"	3 wide Back-to-Back Portrait	56.7 kg	82.6 x 174.8 x 29.2 cm	Any Width x 100 - 800 mm	51 mm	64
LCM2X1U FUSION [™] SERIES		 40 - 55"	2 wide Landscape	56.7 kg	42.7 x 185.1 x 20.1 cm	Any Width x 100 - 400 mm	N/A	64
LCM2X1UP FUSION [™] SERIES		 40 - 55"	2 wide Portrait	56.7 kg	82.6 x 119 x 20.1 cm	Any Width x 100 - 800 mm	N/A	65
LCB2X1U FUSION [™] SERIES		 40 - 55"	2 wide Back-to-Back Landscape	45.4 kg	42.5 x 185.1 x 29.6 cm	Any Width x 100 - 400 mm	N/A	65
LCB2X1UP FUSION [™] SERIES		 40 - 55"	2 wide Back-to-Back Portrait	45.4 kg	82.6 x 119 x 29.6 cm	Any Width x 100 - 800 mm	N/A	65

CEILING DISPLAY MOUNTS								
Model	Product	Screen Size	Configuration	Weight Capacity (per screen)	Dimensions (HxWxD)	Mounting Patterns (W,H)	Tilt	Page
XCM7000 FUSION [™] SERIES		 60 - 90"	Single Landscape	136 kg	425 x 884 x 203 mm	800 x 400 mm	+7.5°/ -20°	66
XCB7000 FUSION [™] SERIES		 60 - 90"	Back-to-Back Landscape	136 kg	425 x 884 x 300 mm	800 x 400 mm	+7.5°/ -20°	66
XCM1U FUSION [™] SERIES		 60 - 90"	Single Landscape	113.4 kg	425 x 884 x 201 mm	200 x 100 - 800 x 400 mm	+5°, -20°	67
XCB1U FUSION [™] SERIES		 60 - 90"	Back-to-Back Landscape	90.7 kg	425 x 884 x 296 mm	200 x 100 - 800 x 400 mm	+5°, -20°	67
LCM1U FUSION [™] SERIES		 32 - 60"	Single Landscape	56.7 kg	420 x 681 x 162 mm	200 x 100 - 616 x 400 mm	+5°, -20°	67
LCM1UP FUSION [™] SERIES		 32 - 60"	Single Portrait	56.7 kg	826 x 529 x 162 mm	200 x 100 - 460 x 800 mm	+5°, -20°	68
LCB1U FUSION [™] SERIES		 32 - 60"	Back-to-Back Landscape	56.7 kg	420 x 681 x 259 mm	200 x 100 - 616 x 400 mm	+5°, -20°	68
LCB1UP FUSION [™] SERIES		 32 - 60"	Back-to-Back Portrait	56.7 kg	826 x 529 x 259 mm	200 x 100 - 460 x 800 mm	+5°, -20°	68
LCM1X2U FUSION [™] SERIES		 32 - 60"	1 wide x 2 tall Single-Sided Landscape	56.7 kg	420 x 681 x 162 mm	200 x 100 - 616 x 400 mm	+5°, -20°	69
LCB1X2U FUSION [™] SERIES		 32 - 60"	1 wide x 2 tall Back-to-Back Landscape	45.3 kg	420 x 681 x 259 mm	200 x 100 - 616 x 400 mm	+5°, -20°	69

QUICK REFERENCE CHART











 = QUALIFIES FOR LEED CREDIT













CEILING DISPLAY MOUNTS								
Model	Product	Screen Size	Configuration	Weight Capacity (per screen)	Dimensions (HxWxD)	Mounting Patterns (W,H)	Tilt	Page
LCM4U FUSION [®] SERIES		 32 - 65"	Quad Mount	38 kg	47.5 142.2 x 142.2 cm	200 x 200 - 600 x 400 mm	+5°, -20°	69
LCM3U FUSION SERIES		 32 - 65"	Triple Mount	57 kg	46.2 118.4 x 118.4 cm	200 x 200 - 600 x 400 mm	+5°, -20°	69
MCM1U FUSION SERIES		 26 - 50"	Single Landscape or Portrait	56.7 kg	420 x 529 x 162 mm	200 x 100 - 460 x 400 mm	+5°, -20°	70
MCB1U FUSION SERIES		 26 - 50"	Back-to-Back Landscape	56.7 kg	419 x 529 x 259 mm	200 x 100 - 460 x 400 mm	+5°, -20°	70
MCM1X2U FUSION SERIES		 26 - 50"	1 wide x 2 tall Single-Sided Landscape	56.7 kg	419 x 529 x 162 mm	200 x 100 - 460 x 400 mm	+5°, -20°	70
MCB1X2U FUSION SERIES		 26 - 50"	1 wide x 2 tall Back-to-Back Landscape	45.3 kg	420 x 529 x 259 mm	200 x 100 - 460 x 400 mm	+5°, -20°	70
Model	Product	Screen Size	Weight Capacity	Dimensions (HxWxD)	Mounting Patterns (W,H)	Tilt	Page	
CM2C40UI AUTOMATED		 32 - 61"	86.2 kg	794 x 603 x 197 mm	200 x 200 - 862 x 517 mm	N/A	75	
TPSU		 42 - 71"	68 kg	412 x 433 x 27 mm	200 x 200 - 862 x 517 mm	N/A	76	
TPMU		 42 - 71"	68 kg	412 x 433 x 86 mm	200 x 200 mm - 862 x 517 mm	±15°	76	
JPPU		 26 - 45"	34 kg	189 x 152 x 89 mm	100 x 100 mm - 400 x 400 mm	±15°	76	
FREESTANDING VIDEO WALL DISPLAY MOUNTS								
Model	Product	Screen Size	Configuration	Weight Capacity (per screen)	Dimensions (HxWxD)	Mounting Patterns (W,H)	Height Adjust (per screen)	Page
LVM3X3U FUSION SERIES		 42 - 46"	3 wide x 3 tall Freestanding Landscape	45.4 kg	235 x 274.3 x 102.6 cm	Any Width x 100 - 400 mm	19 mm	79
LBM3X3U FUSION SERIES		 42 - 46"	3 wide x 3 tall Bolt-down Landscape	45.4 kg	231 x 277 x 23.9 cm	Any Width x 100 - 400 mm	19 mm	79
LVM3X2U FUSION SERIES		 42 - 46"	3 wide x 2 tall Freestanding Landscape	56.7 kg	189.3 x 274.3 x 102.6 cm	Any Width x 100 - 400 mm	19 mm	79
LVM3X2UP FUSION SERIES		 42 - 46"	3 wide x 2 tall Freestanding Portrait	45.4 kg	271 x 172.7 x 102.6 cm	100 - 800 mm x Any Height	19 mm	79
LBM3X2U FUSION SERIES		 42 - 46"	3 wide x 2 tall Bolt-down Landscape	56.7 kg	185.2 x 276.6 x 23.9 cm	Any Width x 100 - 400 mm	19 mm	80
LBM3X2UP FUSION SERIES		 42 - 46"	3 wide x 2 tall Bolt-down Portrait	45.4 kg	250.4 x 172.7 x 24.4 cm	100 - 800 mm x Any Height	19 mm	80
LVM3X1UP FUSION SERIES		 42 - 46"	3 wide x 1 tall Freestanding Portrait	56.7 kg	225.3 x 172.7 x 102.6 cm	100 - 800 mm x Any Height	19 mm	80













QUICK REFERENCE CHART

 = QUALIFIES FOR LEED CREDIT

FREESTANDING VIDEO WALL DISPLAY MOUNTS								
Model	Product	Screen Size	Configuration	Weight Capacity (per screen)	Dimensions (HxWxD)	Mounting Patterns (W,H)	Height Adjust (per screen)	Page
LBM3X1UP FUSION SERIES		 42 - 46"	3 wide x 1 tall Bolt-down Portrait	56.7 kg	204.7 x 172.7 x 24.4 cm	100 - 800 mm x Any Height	19 mm	80
LVM2X2U FUSION SERIES		 42 - 50"	2 wide x 2 tall Freestanding Landscape	56.7 kg	2045 x 1842 x 1026 mm	Any Width x 100 - 400 mm	19 mm	81
LVM2X2UP FUSION SERIES		 42 - 50"	2 wide x 2 tall Freestanding Portrait	45.4 kg	271 x 116.8 x 102.6 cm	100 - 800 mm x Any Height	19 mm	81
LBM2X2U FUSION SERIES		 42 - 50"	2 wide x 2 tall Bolt-down Landscape	56.7 kg	185.2 x 185.2 x 23.9 cm	Any Width x 100 - 400 mm	19 mm	81
LBM2X2UP FUSION SERIES		 42 - 50"	2 wide x 2 tall Bolt-down Portrait	45.4 kg	250.4 x 116.8 x 24 cm	100 - 800 mm x Any Height	19 mm	81



FREESTANDING DISPLAY MOUNTS								
Model	Product	Screen Size	Weight Capacity	Dimensions (HxWxD)	Mounting Patterns (W,H)	Center of Display to Floor Range	Tilt	Page
XVAU FUSION SERIES		 37 - 70"	113 kg	139.5 x 98.6 x 73.7 cm	200 x 200 - 800 x 400 mm	106.4 - 128 cm	±2.5°	84
XPAU FUSION SERIES		 55 - 100"+	136 kg	187.7 x 147.2 x 87.8 cm	200 x 200 - 800 x 400 mm	121.3 - 166.2 cm	±5°	84
LPAU FUSION SERIES		 40 - 80"	90.7 kg	180.1 x 114.3 x 84.4 cm	200 x 200 - 800 x 400 mm	127.1 - 177.9 cm	±5°	85
LFAU FUSION SERIES		 40 - 80"	90.7 kg	183.9 x 96.8 x 77.7 cm	200 x 200 - 800 x 400 mm	113 - 164 cm	±5°	85
MPAU FUSION SERIES		 37 - 55"	56.7 kg	197.9 x 121.4 x 81.3 cm	200 x 100 - 600 x 400 mm	127 - 177 cm	±5°	85
MFAU FUSION SERIES		 37 - 55"	56.7 kg	183.9 x 96.8 x 77.7 cm	200 x 100 - 600 x 400 mm	113 - 163 cm	±5°	85















Model	Product	Screen Size	Weight Capacity	Dimensions (HxWxD)	Mounting Patterns (W,H)	Maximum Extension	Overall Travel	Page
CM2L40 AUTOMATED		 32 - 61"	86.2 kg	77.8 x 60.3 x 19.5 cm	200 x 200 - 862 x 517 mm	180.3 cm	101.6 cm	88

Model	Product	Screen Size	Weight Cap. (per screen)	Dimensions (HxWxD)	Mounting Patterns (W,H)	Center of Display to Floor Range	Tilt	Page
PFCU		 42 - 71"	90.7 kg	207.3 x 94.3 x 81.6 cm	200 x 200 - 862 x 517 mm	122 - 183 cm	±15°	89
PFIU		 42 - 71"	90.7 kg	238.8 x 91.4 x 76.2 cm	200 x 200 - 862 x 517 mm	130 - 217 cm	±15°	89
MFCU		 30 - 55"	56.7 kg	197.5 x 94.3 x 81.6 cm	100 x 100 - 709 x 431 mm	122 - 183 cm	±15°	89
MFIU		 30 - 55"	56.7 kg	232.7 x 91.4 x 76.2 cm	100 x 100 - 709 x 431 mm	130 - 218 cm	±15°	90

QUICK REFERENCE CHART

 = QUALIFIES FOR LEED CREDIT

TABLE STAND DISPLAY MOUNTS								
Model	Product	Screen Size	Weight Capacity	Dimensions (HxWxD)	Mounting Patterns (W,H)	Height Adjust	Swivel Options	Page
STLU		M 32 - 52"	56.7 kg	603 x 698 x 140 mm	100 x 100 - 600 x 400 mm	N/A	15°, 30°, 45° or 90°	92
PTSU		M 30 - 50"	45.4 kg	545 x 607 x 278 mm	200 x 200 - 860 x 515 mm	102 mm	N/A	92
STS1		S 18 - 30"	13.6 kg	409 x 152 x 175 mm	75 x 75 - 100 x 100 mm	130 mm	90°, 180°, 270°	92

















DESK MONITOR MOUNTS								
Model	Product	Minimum Depth from Back of Desk	Maximum Extension	Weight Capacity (per monitor)	Colors	Page		
K1C220 KONTOUR™ SERIES		90 mm	523 mm	2.3 - 9.9 kg	S B	94		
K1C210 KONTOUR SERIES		62 mm	352 mm	2.3 - 11.3 kg (per monitor)	S B	94		
K1C22H KONTOUR SERIES		166 mm	597 mm	0.9 - 4.1 kg	S B	94		
K1C120 KONTOUR SERIES		140 mm	571 mm	2.3 - 9.9 kg	S B	94		
K1C110 KONTOUR SERIES		62 mm	400 mm	2.3 - 11.3 kg (per monitor)	S B	95		
K1D230 KONTOUR SERIES		62 mm	714 mm	2.3 - 4.54 kg (per monitor)	S B	95		
K1D220 KONTOUR SERIES		105 mm	548 mm	2.3 - 11.3 kg	S B	95		
K1D22H KONTOUR SERIES		118 mm	549 mm	0.9 - 4.1 kg	S B	95		
K1D130 KONTOUR SERIES		62 mm	648 mm	2.3 - 4.54 kg (per monitor)	S B	96		
K1D120 KONTOUR SERIES		92 mm	523 mm	2.3 - 11.3 kg	S B	96		
K2C220 KONTOUR SERIES		105 mm	448 mm	9.9 kg	S B	98		
K2C22H KONTOUR SERIES		166 mm	509 mm	0.9 - 4.1 kg	S B	98		
K2C120 KONTOUR SERIES		152 mm	495 mm	9.9 kg	S B	99		
K2C110 KONTOUR SERIES		152 mm	324 mm	9.9 kg	S B	99		

(Silver displays shown with Apple® Cinema Display adapter, not included.)

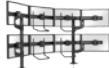

QUICK REFERENCE CHART

 = QUALIFIES FOR LEED CREDIT

DESK MONITOR MOUNTS								
Model	Product	Center of Display to Floor/Table Range	Maximum Width (per monitor)	Minimum Depth	Typical Screen Size	Weight Capacity (per monitor)	Color	Page
K3F220B KONTOUR™ SERIES		460 mm	736 mm	±12°	10 - 27"	6.8 kg	B	102
K3G220B KONTOUR SERIES		460 mm	736 mm	±12°	10 - 27"	6.8 kg	B	102
K3G320B KONTOUR SERIES		460 mm	2 x 2: 1301 mm 3 x 2: 650 mm	±12°	10 - 30"	6.8 kg	B	102
K3F310B KONTOUR SERIES		N/A	Dual: 1301 mm Triple: 650 mm	Outer - ±12° Center - ±10°	Dual: up to 30" Triple: up to 27"	6.8 kg	B	103
K3G310B KONTOUR SERIES		N/A	Dual: 1301 mm Triple: 650 mm	Outer - ±12° Center - ±10°	Dual: up to 30" Triple: up to 27"	6.8 kg	B	103
K3F120B KONTOUR SERIES		460 mm	N/A	±10°	10 - 30"	6.8 kg	B	103
K3G120B KONTOUR SERIES		460 mm	N/A	±10°	10 - 30"	6.8 kg	B	103
K4G610B KONTOUR SERIES		291 - 463 mm	614 mm	815 mm	up to 24"	6.8 kg	B	105
K4G510B KONTOUR SERIES		291 - 463 mm	614 mm	592 mm	up to 24"	6.8 kg	B	105
K4G410B KONTOUR SERIES		291 - 463 mm	614 mm	396 mm	up to 24"	6.8 kg	B	106
K4G310B KONTOUR SERIES		291 - 463 mm	614 mm	239 mm	up to 24"	6.8 kg	B	106
K4G210B KONTOUR SERIES		291 - 463 mm	943 mm	239 mm	up to 24"	6.8 kg	B	106
K4G120B KONTOUR SERIES		291 - 463 mm	406 mm	239 mm	up to 24"	6.8 kg	B	106
K4G620 KONTOUR SERIES		269 - 1107 mm	584 mm	815 mm	up to 24"	6.8 kg	B	107
K4G520 KONTOUR SERIES		269 - 1107 mm	584 mm	592 mm	up to 24"	6.8 kg	B	107
K4G420 KONTOUR SERIES		269 - 1107 mm	584 mm	396 mm	up to 24"	6.8 kg	B	107
K4G320 KONTOUR SERIES		269 - 1107 mm	584 mm	318 mm	up to 24"	6.8 kg	B	107









WALL MONITOR MOUNTS								
Model	Product	Minimum Depth from Wall	Maximum Extension	Tilt	Weight Capacity (per monitor)	Colors	Page	
K1W220 KONTOUR SERIES		62 mm	525 mm	+75°, -10°	2.3 - 11.3 kg	S B	110	



(Silver displays shown with Apple® Cinema Display adapter, not included.)

QUICK REFERENCE CHART





 = QUALIFIES FOR LEED CREDIT

WALL MONITOR MOUNTS

Model	Product	Minimum Depth from Wall	Maximum Extension	Tilt	Weight Capacity (per monitor)	Colors	Page
K1W22H KONTOUR™ SERIES		166 mm	509 mm	±10°	0.9 - 4.1 kg	S B	110
K1W120 KONTOUR SERIES		62 mm	512 mm	+75°, -10°	2.3 - 11.3 kg	S B	110
K1W110 KONTOUR SERIES		62 mm	341 mm	+75°, -10°	2.3 - 11.3 kg	S B	110
K2W220 KONTOUR SERIES		74 mm	450 mm	±15°	11.3 kg	S B	112
K2W22H KONTOUR SERIES		166 mm	509 mm	±10°	6.8 kg	S B	112
K2W120 KONTOUR SERIES		74 mm	437 mm	±15°	18.1 kg	S B	113
K2W110 KONTOUR SERIES		74 mm	265 mm	±15°	18.1 kg	S B	113
KOW100		66 mm	N/A	+75°, -10°	11.3 kg	S B	114

Model	Product	Max. Monitor Width	Extension	Minimum Depth	Arm Rotation	Typical Screen Size	Tilt	Weight Cap. (per monitor)	Page
K4W310B KONTOUR SERIES		614 mm	412 mm	239 mm	0 - 20°	up to 24"	±12°	6.8 kg	115
K4W210B KONTOUR SERIES		943 mm	412 mm	239 mm	0 - 20°	up to 30"	±12°	6.8 kg	115
K4W120B KONTOUR SERIES		406 mm	412 mm	94 mm	0 - 20°	up to 24"	±10°	6.8 kg	116

POLE MONITOR MOUNTS



Model	Product	Minimum Depth from Pole	Maximum Extension	Tilt	Weight Capacity (per monitor)	Colors	Page
K1P220 KONTOUR SERIES		62 mm	510 mm	+75°, -10°	2.3 - 11.3 kg	S B	117
K1P22H KONTOUR SERIES		88 mm	523 mm	+75°, -10°	0.9 - 4.1 kg	S B	117
K1P120 KONTOUR SERIES		64 mm	493 mm	+75°, -10°	2.3 - 11.3 kg	S B	118
K1P110 KONTOUR SERIES		64 mm	322 mm	+75°, -10°	2.3 - 11.3 kg	S B	118

(Silver displays shown with Apple® Cinema Display adapter, not included.)



QUICK REFERENCE CHART

 = QUALIFIES FOR LEED CREDIT













POLE MONITOR MOUNTS							
Model	Product	Minimum Depth from Pole	Maximum Extension	Tilt	Weight Capacity (per monitor)	Colors	Page
K2P220 KONTOUR™ SERIES		74 mm	434 mm	±15°	11.3 kg	S B	120
K2P22H KONTOUR SERIES		88 mm	434 mm	±15°	6.8 kg	S B	120
K2P120 KONTOUR SERIES		74 mm	422 mm	±15°	18.1 kg	S B	121
K2P110 KONTOUR SERIES		74 mm	250 mm	±15°	18.1 kg	S B	121
Model	Product	Minimum Depth from Pole	Typical Screen Size	Tilt	Weight Capacity	Colors	Page
KOP100		66 mm	10 - 30"	+75°, -10°	18.1 kg	S B	122

TABLET MOUNTS								
Model	Product	Dimensions (HxWxD)	Mounting Patterns	Tilt	Weight Capacity (per monitor)	Page		
KOW100BXI2B		286 x 217 x 24 mm	100 x 100 mm	+40° / -10°	0.9 kg	124		
KOW100BXI2TB		286 x 217 x 24 mm	100 x 100 mm	+40° / -10°	0.9 kg	124		
Model	Product	Dimensions (HxWxD)	Mounting Patterns	Tilt	Weight Capacity (per monitor)	Page		
FSRI2T		290 x 206 mm	N/A	N/A	0.9 kg	124		
Model	Product	Manual Height Adjustment	Minimum Depth	Mounting Pattern	Tilt	Desktop Thickness	Weight Capacity	Page
K1D220BXI2B		506 mm	53 mm	75 x 75 mm, 100 x 100 mm	+75°, -10°	19 - 64 mm	2.3 - 11.3 kg	125
K1C120BXI2B		273 mm	54 mm	100 x 100 mm	+75°, -10°	13 - 83 mm	2.3 - 11.3 kg	125

(Silver displays shown with Apple® Cinema Display adapter, not included.)

QUICK REFERENCE CHART

 = QUALIFIES FOR LEED CREDIT

RACK SYSTEMS				
Model	Product	Available Depths	Available Heights	Page
S1 SERIES KNOCK DOWN RACKS		584 or 711 mm Depths	12, 20, 28, 36, 41 or custom space	127 - 128
G1 SERIES GANGABLE RACKS		584 or 838 mm Depths	28, 36 or 44 space	129 - 130
E1 SERIES ENCLOSED RACKS		584 or 711 mm Depths	20, 28, 36 or 44 space	131 - 132
F1 SERIES FREESTANDING RACKS		508 mm Depth	12, 20 or 28 space	133
POTR & POTR-XL PULL-OUT RACKS		467 or 533 mm Depths	8 or 24 space	135
ROTR ROTATING RACKS		480 mm Depth	8 or 24 space	135
ROTR-XL ROTATING RACKS		582 mm Depth	8 or 24 space	135
ROTR-HD ROTATING RACKS		597 mm Depth	24 - 44 or custom space	135
CPROTR CAPTIVE ROTATING RACKS		711 mm Depth	35 or 42 space	136
W2 SERIES FIXED WALL RACKS		420 mm Depth	8 or 12 space	137
ER FREESTANDING RACKS		406 or 457 mm Depths	4 - 20 space	138
ERK FREESTANDING RACKS		406 or 508 mm Depths	4 - 16 space	138





CEILING PROJECTOR MOUNTS

RPE ELITE® SERIES PROJECTOR MOUNT

FEATURES



MICROZONE™ ADJUSTMENTS
Designed with MicroZone Adjustments to make projector registration fast and precise.



CENTRIS® TECHNOLOGY
Enables effortless fingertip positioning and self-adjusts to support different projector weights.



CABLE MANAGEMENT
Route cables through the top of the mount without additional accessories.



QUICK CONNECT/DISCONNECT
Disconnecting maintains registration without affecting pre-set adjustments.



SECURITY
Keyed locking and steel-into-steel locking hardware at all connection points to protect against theft.



MULTIPLE CONNECTION OPTIONS
Mounting options include: CPAE pin connection column system, CMS threaded column system, 6mm threaded rods, and flush mounting to the ceiling.

KITEC030045 ALL-IN-ONE PROJECTOR MOUNT KIT



Chief's projector kits offer convenient flexibility with a super sleek design and even quicker installation. Bundled kit includes:

- RSMEU Mini Elite® Universal Projector Mount
- CPA116 Flat Ceiling Plate
- 300-450 mm Telescoping Column

Weight Capacity	Roll, Pitch and Yaw	Extension	Dimensions (LxWxH)	Colors
11.3 kg	3°, 15°, 20°	300 - 450 mm	144 x 144 x 535 mm	W B



KITEC045080 ALL-IN-ONE PROJECTOR MOUNT KIT



Chief's projector kits offer convenient flexibility with a super sleek design and even quicker installation. Bundled kit includes:

- RSMEU Mini Elite® Universal Projector Mount
- CPA116 Flat Ceiling Plate
- 450-800 mm Telescoping Column

Weight Capacity	Roll, Pitch and Yaw	Extension	Dimensions (LxWxH)	Colors
11.3 kg	3°, 15°, 20°	500 - 800 mm	144 x 144 x 885 mm	W B



KITEC080135 ALL-IN-ONE PROJECTOR MOUNT KIT



Chief's projector kits offer convenient flexibility with a super sleek design and even quicker installation. Bundled kit includes:

- RSMEU Mini Elite® Universal Projector Mount
- CPA116 Flat Ceiling Plate
- 800-1350 mm Telescoping Column

Weight Capacity	Roll, Pitch and Yaw	Extension	Dimensions (LxWxH)	Colors
11.3 kg	3°, 15°, 20°	800 - 1350 mm	144 x 144 x 1435 mm	W B

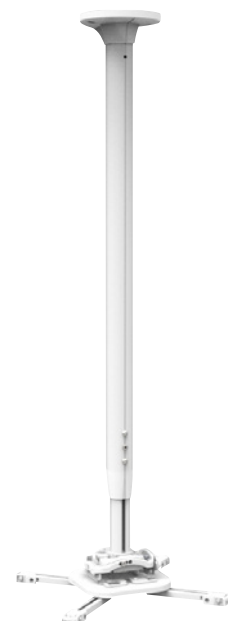

RPMEU RPE ELITE® PROJECTOR MOUNT



Chief's elite ceiling projector mounts are packed with easy-to-use features that save time and provide projector security.

Weight Capacity	Roll, Pitch and Yaw	Dimensions (HxWxD)	Colors
22.7 kg	3°, 20°, 360°	69 x 165 x 140 mm	W B

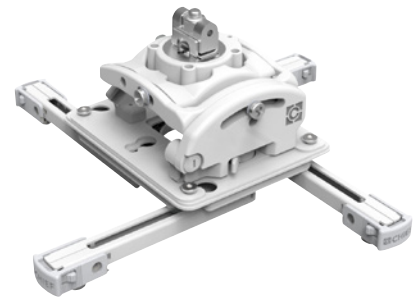

RSMEU MINI ELITE™ PROJECTOR MOUNT



Ideal for smaller projector models, these miniature versions of the Elite mounts include all the same great features in almost half the size.

Weight Capacity	Roll, Pitch and Yaw	Dimensions (HxWxD)	Colors
11.3 kg	3°, 15°, 360°	46 x 111 x 129 mm	W B



RPEU® SERIES CEILING MOUNTS* FEATURES



INDEPENDENT ADJUSTMENTS
Includes roll, pitch and yaw adjustments for quick and precise projector alignment.



ALL-POINTS SECURITY
Exclusive steel-into-steel locking hardware at all connection points to protect against theft.



QUICK CONNECT/DISCONNECT
Disconnecting maintains registration without affecting pre-set adjustments.



MULTIPLE CONNECTION OPTIONS
Mounting options include: CPAE pin connection column system, CMS threaded column system, 6 mm threaded rods and flush mounting to ceiling.



CABLE MANAGEMENT
Route cables through the top of the mount without additional accessories.

RPEU PROJECTOR MOUNT



Chief's standard ceiling projector mount is installed in more offices, schools and homes worldwide than any other mount.

Weight Capacity	Roll, Pitch and Yaw	Dimensions (HxWxD)	Colors
22.7 kg	4°, 25°, 360°	44 x 165 x 140 mm	W B

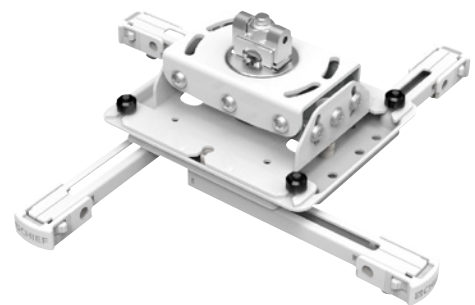

RSEU MINI RPE PROJECTOR MOUNT



Offers a compact design for smaller projectors with all the same great features as the standard RPEU Series.

Weight Capacity	Roll, Pitch and Yaw	Dimensions (HxWxD)	Colors
11.3 kg	3°, 20°, 360°	37 x 111 x 112 mm	W B



APPLICATION SPECIFIC CEILING PROJECTOR MOUNTS

VCMEU HEAVY DUTY MOUNT



Heavy-duty steel mount for mounting heavy LCD projectors. Micro adjustments allow you to quickly achieve registration.

Weight Capacity	Roll, Pitch and Yaw	Dimensions (HxWxD)	Color
113.4 kg	5°, 20°, 360°	97 x 432 x 235 mm	B



KITMZ006S SUSPENDED CEILING KIT



Weight Capacity	Colors
11.3 kg	S

Bundled kit includes:

- RSMAUS Mini Elite® Universal Projector Mount
- CMSZ006S Fully Threaded Extension Column
- CMS440 Lightweight Suspended Ceiling Kit

Fits standard 600 x 600 ceiling tiles.



PIN CONNECTION PROJECTOR MOUNT ACCESSORIES

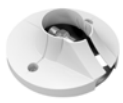

CPA116	Weight Capacity	Colors
Flat Ceiling Plate	34 kg	Ⓜ Ⓟ



CPA330	Weight Capacity
Pin Connection Offset Ceiling Plate	226.8 kg



CPA365	Weight Capacity
Pin Connection Pole and Truss Adapter	226.8 kg



CPA395	Weight Capacity
Pin Connection Angled Ceiling Plate	226.8 kg



CPA263	Weight Capacity	Colors
CPA Column to CPA Column Connector	226.8 kg	Ⓜ Ⓟ



CPA264	Weight Capacity
Pin Connection Coupler	226.8 kg



CMA345	Weight Capacity
Structural Ceiling Plate	226.8 kg



CPAE Columns	Weight Capacity
Fixed, pin-connection extension columns available in black and white [†]	226.8 kg
Model	Length
CPAE030	300 mm
CPAE080	800 mm
CPAE100	1000 mm
CPAE150	1500 mm
CPAE300	3000 mm
[†] All part numbers listed are black. To order white add W to the end of the part number.	



CPA640	Compatibility	Colors
Decorative Tile Ring	Threaded & CPA Columns	Ⓜ Ⓟ



CMA274	Colors
Quick-Snap Cable Cover - 1219 mm long	Ⓜ Ⓟ

THREADED PROJECTOR MOUNT ACCESSORIES



CMS115	Colors	Weight Capacity
Speed-Connect™ Ceiling Plate	Ⓜ Ⓟ	226.8 kg



CMA330	Weight Capacity
Offset Ceiling Plate - 203 mm	226.8 kg







CMA395	Colors	Weight Capacity
Angled Ceiling Plate	Ⓟ Ⓜ	226.8 kg



CMA347	Weight Capacity
Vibration Isolating Coupler	15.9 kg



THREADED PROJECTOR MOUNT ACCESSORIES



	CMS440	Weight Capacity
	Speed-Connect Above-Tile Suspended Ceiling Kit	22.7 kg

	CMA640	Compatibility	Colors
	Decorative Ring, 48 mm ID	Threaded & CPA Columns	  

	CMA643	Compatibility
	Decorative Ring, 62 mm ID - Silver	CMS Outer Adjustable Columns

	CMA351	Weight Capacity
	Heavy Duty Swivel Adapter	226.8 kg

	CMA110	Colors	Weight Capacity
	Ceiling Plate - 203 mm	 	226.8 kg

	CMSZ006	Colors	Weight Capacity
	152 mm Fully Threaded Column		226.8 kg

	CMS Fixed Columns	Weight Capacity	
	Fixed 1 1/2" NPT extension columns available in black, silver and white*	500 lbs (226.8 kg)	
Model	Length	Model	Length
CMS003*	3" (76 mm)	CMS024	2' (0.6 m)
CMS006*	6" (152 mm)	CMS036	3' (0.9 m)
CMS009	9" (229 mm)	CMS048	4' (1.2 m)
CMS012	12" (305 mm)	CMS060	5' (1.5 m)
CMS018	18" (457 mm)	CMS072	6' (1.8 m)

* All part numbers listed are black. To order white add a W to the end of the part number.

	CMS Adjustable Columns	Weight Capacity	
	Adjustable threaded extension columns available in black and white*	226.8 kg	
Model	Length	Model	Length
CMS006009	152 - 229 mm	CMS0203	0.6 - 0.9 m
CMS009012	229 - 305 mm	CMS0305	0.9 - 1.5 m
CMS012018	305 - 457 mm	CMS0406	1.2 - 1.8 m
CMS018024	457 - 610 mm	CMS0507	1.5 - 2.1 m

* All part numbers listed are black. To order white add a W to the end of the part number.

CEILING PROJECTOR MOUNT ACCESSORIES

	CMS491	Weight Capacity
	Half Tile Plenum Storage Box	45 kg

	CMS491C	Weight Capacity
	Half Tile Plenum Storage Box w/ Column Drop	45 kg

	CMS492	Weight Capacity
	Full Tile Plenum Storage Box	45 kg

	CMS492C	Weight Capacity
	Full Tile Plenum Storage Box w/ Column Drop	45 kg

CEILING PROJECTOR MOUNT ACCESSORIES



PG1A	Max Equipment Size (HxWxD)	Colors
Large Projector Guard	191 x 508 x 518 mm	B W



PG2A	Max Equipment Size (HxWxD)	Colors
Small Projector Guard	191 x 406 x 406 mm	B W



PG3A	Max Equipment Size (HxWxD)	Colors
Extra Large Projector Guard	288 x 635 x 633 mm	B W



HC1	Includes
Heavy-Duty Cable system	SA1, cable, padlock, security pads, super glue



LC1	Includes
Security Cable Lock Kit	Coiled cable, padlock, security pads, super glue

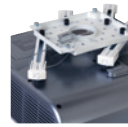

SEC2	Compatibility
Security Cable Kit for SLBU	RPE, RPME, RSE and RSME Series



LCD2C	Compatibility
Dual Projector Ceiling Stacker	Requires two RPE or RPME projector mounts



LCD2TS	Compatibility
Dual Projector Table Stand Stacker	Requires two RPE or RPME projector mounts



LCDPA	Compatibility
Stacker Arm	RPE and RPME projector mounts



LCDCP	Weight Capacity
Stacker Ceiling Plate	45.4 kg



AUTOMATED PROJECTOR MOUNTS

AUTOMATED PROJECTOR MOUNTS FEATURES



QUIET OPERATION

Provides exceptionally smooth and quiet movement, making it a great option for homes and corporate offices.



MULTIPLE CONTROL OPTIONS

Choose from single push-button, low-voltage controller and IR options. Also accepts 5-30V AC/DC for triggering commands. AMX/Crestron control compatibility.



SAFE & SUSTAINABLE

CE, UL, TUV, FC and WEEE certifications recognize safe design and environmentally friendly construction.



MULTIPLE INSTALLATION OPTIONS

Multiple mounting options for finished and suspended ceilings including threaded extension columns, threaded rods and suspension cables.

SL220 SMART-LIFT



Simple 3-step installation process requires only one person. Designed to fit 600 x 600 mm suspended ceiling systems.

Weight Capacity	Extension	Max Projector Size (HxWxD)	Ceiling Opening (HxWxD)	Ceiling Closure (WxD)
13.6 kg	216 mm	241 x 419 x 470 mm	284 x 597 x 597 mm	489 x 526 mm



RSMEUW projector mount is required. Remote control and IR eye are included.

SL236I SMART-LIFT



Provides 914 mm of downward travel with three stopping positions. Includes adjustments for precise positioning. Order SL236SPI for suspended ceiling installations and SL236FDI for fixed/structured ceiling installations.

Weight Capacity	Extension	Max Projector Size (HxWxD)	Ceiling Opening (HxWxD)	Ceiling Closure (WxD)
15.9 kg	914 mm	235 x 521 x 578 mm	282 x 648 x 724 mm	607 x 607 mm



SLBUW Interface is required. Remote control and IR eye are not included.

SL151I SMART-LIFT



Provides exceptionally smooth and quiet movement. Great for suspended and finished ceilings in homes and corporate offices.

Weight Capacity	Extension	Max Projector Size (HxWxD)	Ceiling Opening (HxWxD)	Ceiling Closure (WxD)
15.9 kg	211 mm	213 x 464 x 464 mm	284 x 597 x 597 mm	514 x 515 mm



SLBUW Interface is required. Remote control and IR eye are not included.

AUTOMATED PROJECTOR MOUNT ACCESSORIES







IR10	Compatibility
Infrared Remote Control*	SL151, SL236 and SL220

**Included with SL220i*



WALL PROJECTOR MOUNTS

WM SERIES SHORT THROW MOUNTS FEATURES

- 
PRECISION HEIGHT AND LEVELING
 Industry-first micro height and leveling adjustment.
- 
FAST INSTALLATION
 Innovative quick-connect system for a speedy install.
- 
INTEGRATED CABLE MANAGEMENT
 Fully internal cable management system conceals and protects cables for a clean finish.
- 
VARIABLE EXTENSION OPTIONS
 Telescoping extension and infinite projector placement make it easy to achieve a picture perfect installation.
- 
MULTIPLE INSTALLATION OPTIONS
 Designed for mounting to concrete, block wall, wood or steel studs. Hardware Included.

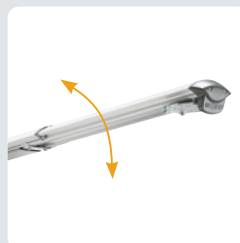

PRECISION HEIGHT
& LEVELING



VARIABLE EXTENSION
OPTIONS

WM210AUS EXTENDS UP TO 495 mm



Small dual stud short throw mount. Includes RSMAUS Mini Elite* Projector Mount.

Weight Capacity	Level	Lateral Shift	Dimensions (HxWxD)
11.3 kg	±3°	330 mm	293 x 499 x 586 mm



WM220AUS EXTENDS UP TO 768 mm



Medium dual stud short throw mount. Includes RSMAUS Mini Elite Projector Mount.

Weight Capacity	Level	Lateral Shift	Dimensions (HxWxD)
11.3 kg	±3°	330 mm	293 x 499 x 904 mm



WM230AUS EXTENDS UP TO 1384 mm



Large dual stud short throw mount. Includes RSMAUS Mini Elite Projector Mount.

Weight Capacity	Level	Lateral Shift	Dimensions (HxWxD)
11.3 kg	±3°	330 mm	293 x 499 x 1513 mm



WM110AUS EXTENDS UP TO 457 mm



Small single stud short throw mount. Includes RSMAUS Mini Elite* Projector Mount.

Weight Capacity	Level	Lateral Shift	Dimensions (HxWxD)
11.3 kg	±3°	N/A	360 x 185 x 551 mm



WM120AUS EXTENDS UP TO 724 mm



Medium single stud short throw mount. Includes RSMAUS Mini Elite Projector Mount.

Weight Capacity	Level	Lateral Shift	Dimensions (HxWxD)
11.3 kg	±3°	N/A	360 x 185 x 869 mm



WM130AUS EXTENDS UP TO 1334 mm



Large single stud short throw mount. Includes RSMAUS Mini Elite Projector Mount.

Weight Capacity	Level	Lateral Shift	Dimensions (HxWxD)
11.3 kg	±3°	N/A	360 x 185 x 1479 mm



WM SERIES SHORT THROW PROJECTOR MOUNT ACCESSORIES



WMAH3S	Compatibility
Wall Mount Height Adjust Accessory 3"	WM Series

WP2 SERIES SHORT THROW MOUNT FEATURES

PRECISION ADJUSTMENT
Integrated micro pitch and lateral shift adjustment to speed up image registration.

VARIABLE EXTENSION OPTION
Projector mount slides along arm for infinite projector placement.

INTEGRATED CABLE MANAGEMENT
Aesthetic covers and internal cable management system conceal and protect cables for a clean finish.

MULTIPLE INSTALLATION OPTIONS
Designed for mounting to concrete, block wall, wood or steel studs Includes mounting hardware.

WP21US EXTENDS UP TO 562 mm



Small economical dual or single stud short throw mount. Includes RSAUS Mini Projector Mount.



Weight Capacity	Level	Lateral Shift	Dimensions (HxWxD)
11.3 kg	±3°	44 mm	219 x 485 x 618 mm

WP22US EXTENDS UP TO 968 mm



Medium economical dual or single stud short throw mount. Includes RSAUS Mini Projector Mount.



Weight Capacity	Level	Lateral Shift	Dimensions (HxWxD)
11.3 kg	±3°	44 mm	219 x 485 x 1025 mm

WP23US EXTENDS UP TO 1375 mm



Large economical dual or single stud short throw mount. Includes RSAUS Mini Projector Mount.



Weight Capacity	Level	Lateral Shift	Dimensions (HxWxD)
11.3 kg	±3°	44 mm	219 x 485 x 1432 mm

WP2 SERIES SHORT THROW PROJECTOR MOUNT ACCESSORIES



CMSH3	Compatibility
Wall Mount Height Adjust Accessory 3"	WP Series, CMS Columns

APPLICATION SPECIFIC WALL PROJECTOR MOUNTS

WMA1S WALL MOUNT ACCESSORY, SINGLE STUD



Heavy duty wall mount accessory for mounting projectors or flat panels in single stud or concrete applications



Weight Capacity	Extension	Dimensions (HxWxD)
Concrete/Wood 68 kg Steel Stud 22.7 kg	292 - 482 mm	361 x 185 x 292 mm

WMA2S WALL MOUNT ACCESSORY, DUAL STUD



A heavy-duty wall mount accessory for mounting projectors or flat panels in dual stud or concrete applications.



Weight Capacity	Extension	Dimensions (HxWxD)
Concrete/Wood 68 kg Steel Stud 34 kg	330 - 533 mm	292 x 470 x 330 mm



INTEGRATED INTERACTIVE SYSTEM FEATURES



FULLY INTEGRATED SYSTEM

A unique solution for the Epson® Brightlink® Pro 1430Wi touch interactive projector and other models, the Integrated Interactive System combines a high performance projection surface with a precision projector mounting system.



VERSATILE PROJECTION SCREEN

Da-Lite® IDEA™ Screen serves as a superior image quality projection screen and writeable marker board surface. Offers gain of 2.5 and a 25-degree viewing half angle.



CUSTOM MOUNT

Features a sleek, custom Chief mount designed to make registration and service extremely fast and easy.

AN2BA INTEGRATED INTERACTIVE SYSTEM



Includes everything needed to install the Epson® BrightLink® Pro 1430Wi Touch Interactive projector in corporate environments. Also compatible with Brightlink Pro 1410Wi, 1420Wi, 595Wi and 585Wi.

Part Number	Weight Capacity	Screen Diagonal	Viewing Angle	Overall Dimensions	Minimum Dry Wall Requirements
AN2BA87	11.3 kg	87"	50°	2041 x 741 x 1680 mm	16 mm or thicker
AN2BA100	11.3 kg	100"	50°	2323 x 741 x 1680 mm	16 mm or thicker





FIXED DISPLAY WALL MOUNTS

FUSION™ FIXED MOUNT FEATURES



CONTROLZONE™ LEVELING
Post-installation fine-tuning of height and leveling eliminates time needed for repositioning the mount and adjusts the entire configuration, not just the display.



CENTERLESS™ SHIFT
Generous post-installation lateral shift allows for perfect display positioning.



CLICKCONNECT™
Tool-less latching makes an audible click when a Fusion mount is safely engaged with the screen.

NEW ENHANCEMENTS

We kept all the features installers love while adding new benefits they asked for. Upgrades include:

- Super stability with set screws to keep the mount rigid
- Nesting spacers to achieve three different depths
- Faster installation with new teardrop design
- Quick-store cords
- Improved cable management with redesigned end caps

XSM1U* 55 - 90" MICRO-ADJUST MOUNT



For extra large displays with wide and/or tall mounting patterns.

Weight Capacity	Dimensions (HxWxD)	Mounting Patterns (W,H)	Max Lateral Shift	Height Adjust
113.4 kg	667 x 1086 x 57 mm	200 x 200 - 1086 x 600 mm	542 mm	25 mm

* Available second quarter, 2015. Order first generation XSMU until then.

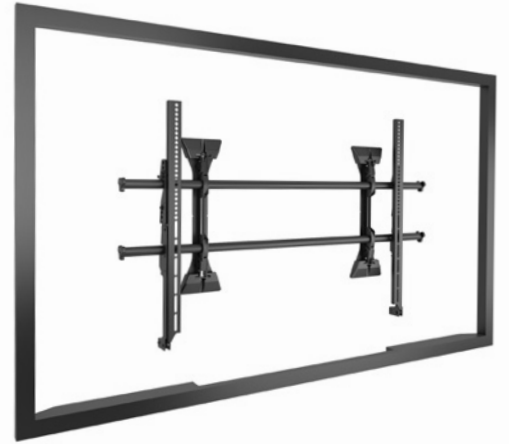

LSM1U* 37 - 80" MICRO-ADJUST MOUNT



Our top performing fixed mount fits most displays on the market.

Weight Capacity	Dimensions (HxWxD)	Mounting Patterns (W,H)	Max Lateral Shift	Height Adjust
90.7 kg	464 x 883 x 51 mm	100 x 100 - 881 x 400 mm	441 mm	25 mm

* Available second quarter, 2015. Order first generation LSMU until then.

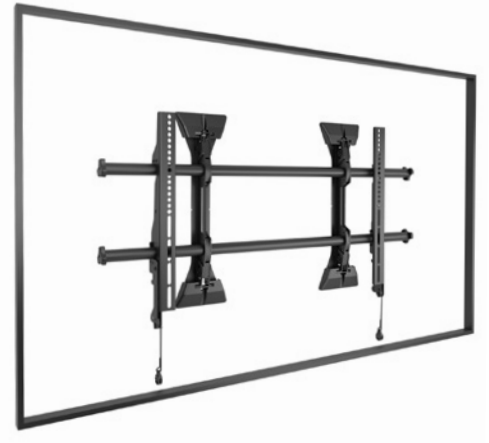

LSA1U* 37 - 80" WALL MOUNT



This option without micro height adjustment is ideal for installs using Chief connector kits for multi-display installations.

Weight Capacity	Dimensions (HxWxD)	Mounting Patterns (W,H)	Max Lateral Shift	Height Adjust
90.7 kg	455 x 883 x 51 mm	100 x 100 - 876 x 400 mm	441 mm	N/A

* Available second quarter, 2015. Order first generation LSAU until then.

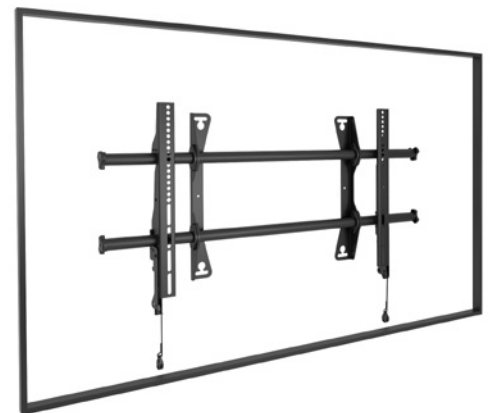

MSM1U* 26 - 47" MICRO-ADJUST MOUNT



The smaller version of the LSM1U for shorter and/or narrower mounting patterns.

Weight Capacity	Dimensions (HxWxD)	Mounting Patterns (W,H)	Max Lateral Shift	Height Adjust
56.7 kg	464 x 654 x 51 mm	100x 100 - 653 x 400 mm	327 mm	25 mm

* Available second quarter, 2015. Order first generation MSMU until then.



MSA1U* 26 - 47" WALL MOUNT



This option without micro height adjustment is ideal for installs using Chief connector kits for multi-display installations.

Weight Capacity	Dimensions (HxWxD)	Mounting Patterns (W,H)	Max Lateral Shift	Height Adjust
56.7 kg	455 x 654 x 51 mm	100 x 100 - 647 x 400 mm	327 mm	N/A

* Available second quarter, 2015. Order first generation MSAU until then.



FUSION™ FIXED MOUNT ACCESSORIES



FCA830/ FCA840+		Compatibility
Center Channel Speaker Adapter		Fusion Fixed & Tilt Wall, Free-standing & Ceiling Mounts
Model	Typical Screen Size	Weight Capacity
FCA830	52 - 80"	9.1 kg
FCA840	70 - 100"+	9.1 kg

* Available second quarter, 2015.



FCA831/ FCA841+		Compatibility
Center Channel Speaker Adapter		Fusion Fixed & Tilt Wall, Free-standing & Ceiling Mounts
Model	Typical Screen Size	Weight Capacity
FCA831	42 - 70"	4.5 kg/side
FCA841	50 - 95"	4.5 kg/side

* Available second quarter, 2015.



FLR100	Weight Capacity	Compatibility
Left/Right Speaker Adapter	9.1 kg	Fusion Fixed & Tilt Wall Mounts



FCC100	Weight Capacity	Compatibility
Center Channel Speaker Adapter	9.1 kg	Fusion Landscape Fixed & Tilt Wall Mounts



FCA102	Equipment Depth Range	Compatibility
Secure CPU/Media Player Adapter	0 - 41 mm	Large & Extra Large Fusion Wall Mounts



FCA103	Compatibility
Extension Accessory for Behind-Mount Storage Space	All Fusion Wall Mounts



FCA101	Compatibility
Lock-Down Collar	Fusion Fixed & Tilt Wall Mounts



FCK000/008/016		Compatibility
Connector Kits		Fusion Fixed & Tilt Wall Mounts
Model	Width	
FCK000	Adds zero length to the poles	
FCK008	203 mm	
FCK016	406 mm	



FCA800/ FCA801+		Compatibility
Above/Below Shelf, Large* Displays		Fusion Fixed & Tilt Wall, Free-standing & Ceiling Mounts
Model	Size	Weight Capacity
FCA800	203 mm	9.1 kg
FCA801	355 mm	9.1 kg

* Typical screen size: 46-70".

* Available second quarter, 2015.



FCA810/ FCA811+		Compatibility
Above/Below Shelf, XL* Displays		Fusion Fixed & Tilt Wall, Free-standing & Ceiling Mounts
Model	Size	Weight Capacity
FCA810	203 mm	9.1 kg
FCA811	355 mm	9.1 kg

* Typical screen size: 70-100".

* Available second quarter, 2015.



FCA820/ FCA821+		Compatibility
Fusion Center Camera Shelf		Fusion Ceiling, Freestanding and Wall Mounts
Model	Size	Weight Capacity
FCA820	203 mm	9.1 kg
FCA821	355 mm	9.1 kg

* Available second quarter, 2015.



FCS100	Dimensions (WxD)	Weight Capacity	Compatibility
Component Shelf	457 x 335 mm	9.1 kg	Fusion Landscape Wall Mounts



FUSION™ FIXED MOUNT ACCESSORIES



FCD100	Compatibility
Stackable Component Shelf	Fusion Landscape Wall Mounts



FCA104	Compatibility
Component Shelf Extender	FCS100, FVS100, FVS150, FCC100, FCD100



FVS100/150	Compatibility	
Video Conference Camera Shelves - Below	Fusion Landscape Wall Mounts	
Model	Shelf Dimensions (WxD)	Weight Capacity
FVS100	203 x 335 mm	4.5 kg
FVS150	305 x 335 mm	4.5 kg



FVS200/250/251	Compatibility	
Video Conference Camera Shelves - Above	Fusion Landscape Wall Mounts	
Model	Shelf Dimensions (WxD)	Weight Capacity
FVS200	203 x 180 mm	4.5 kg
FVS250	305 x 180 mm	4.5 kg
FVS251	356 x 180 mm	4.5 kg



FVS300/350	Compatibility	
Video Conference Camera Shelves - Center	Fusion Fixed & Tilt Wall Mounts	
Model	Shelf Dimensions (WxD)	Weight Capacity
FVS300	203 x 178 mm	4.5 kg
FVS350	305 x 178 mm	4.5 kg



FCA106	Compatibility
Side Cover Accessory	Fusion Fixed & Tilt Wall Mounts

THININSTALL™ FIXED MOUNT FEATURES



ULTRA-LOW PROFILE

At less than the width of a penny, these mounts provide an ultra-thin profile to showcase any flat-screen display.



GLIDE LOCK™

Tool-less latching with a sliding flag for fast installation.



CABLE KICKSTAND

A kickstand makes cable access convenient while the open wall plate allows for easy electrical placement behind the display.



GLIDE LOCK™ LATCH



CABLE MANAGEMENT

LSTU 37 - 63" ULTRA-LOW PROFILE



Thinner than the diameter of a penny, this versatile mount is great for ultra-slim flat panels.

Weight Capacity	Dimensions (HxWxD)	Mounting Patterns (W,H)
56.7 kg	628 x 907 x 10 mm	200 x 200 - 800 x 500 mm



MSTU 26 - 47" ULTRA-LOW PROFILE



Accommodates different mounting patterns than the LSTU and allows for landscape and portrait orientations.

Weight Capacity	Dimensions (HxWxD)	Mounting Patterns (W,H)
56.7 kg	530 x 706 x 10 mm	100 x 100 - 600 x 400 mm



OTHER FIXED WALL MOUNTS

PSMH OVER 60" HEAVY DUTY MOUNTS



A heavy-duty series of mounts for extra large flat panels with custom solutions available.

Model	Weight Capacity	Dimensions (HxWxD)	Mounting Patterns (W,H)
PSMH2840	136.1 kg	635 x 924 x 74 mm	400 x 400 - 800 x 400 mm
PSMH2841	124.7 kg	533 x 495 x 32 mm	400 x 400 mm
PSMH2482	118.8 kg	896 x 1575 x 102 mm	

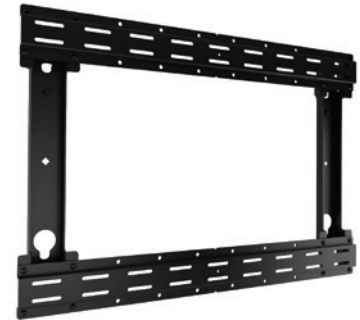

Visit chiefmfg.com for additional PSMH model specifications.

FSRV 10 - 32" WALL MOUNT



A simple wall mount for small displays. The ultra low profile allows for portrait or landscape options with Q-Latch™ mounting system.

Weight Capacity	Dimensions (HxWxD)	Mounting Patterns (W,H)
20.4 kg	178 x 152 x 19 mm	75 x 75 - 200 x 100 mm



PAC101 COMPONENT WALL SHELF

Provides a fast and simple wall installation for CPUs and other components.

Weight Capacity	Dimensions (HxWxD)	Color
9.1 kg	55 x 356 x 264 mm	S B



FIXED CPU MOUNT ACCESSORY



PAC103	Compatibility
Accessory Shelf Safety Strap	PAC101



TILT DISPLAY WALL MOUNTS

FUSION™ TILT MOUNT FEATURES



CONTROLZONE™ LEVELING
Post-installation fine-tuning of height and leveling eliminates time needed for repositioning the mount and adjusts the entire configuration, not just the display.



CENTERLESS™ SHIFT
Generous post-installation lateral shift allows for perfect display positioning.



CENTRIS™ LOW-PROFILE TILT
Uses the center of gravity to balance the screen while maintaining a low profile. The display stays in place until readjusted.



CLICKCONNECT™
Tool-less latching makes an audible click when a Fusion mount is safely engaged with the screen.

NEW ENHANCEMENTS

We kept all the features installers love while adding new benefits they asked for. Upgrades include:

- Super stability with set screws to keep the mount rigid
- Nesting spacers to achieve three different depths
- Faster installation with new teardrop design
- Quick-store cords
- Improved cable management with redesigned end caps

XTM1U 55 - 90" MICRO-ADJUST MOUNT



Works best with extra large displays with wide and/or tall mounting patterns.

Weight Capacity	Dimensions (HxWxD)	Mounting Patterns (W,H)	Max Lateral Shift	Height Adjust	Tilt
113.4 kg	622 x 1086 x 64 mm	200 x 200 - 1250 x 660 mm	542 mm	25 mm	+5°, -12°

* Available second quarter, 2015. Order first generation XTMU until then.

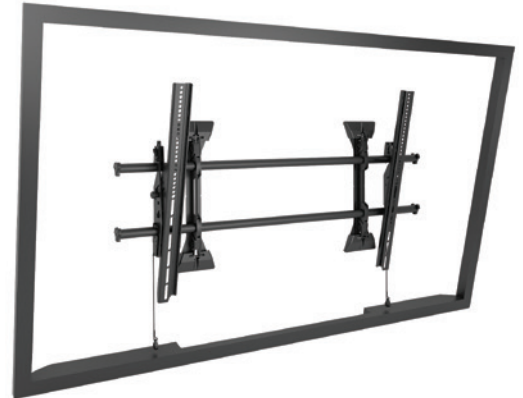

LTM1U 37 - 80" MICRO-ADJUST MOUNT



Our top performing tilt mount fits most displays on the market.

Weight Capacity	Dimensions (HxWxD)	Mounting Patterns (W,H)	Max Lateral Shift	Height Adjust	Tilt
90.7 kg	432 x 883 x 51 mm	100 x 100 - 895 x 505 mm	441 mm	25 mm	+2°, -12°

* Available second quarter, 2015. Order first generation LTMU until then.

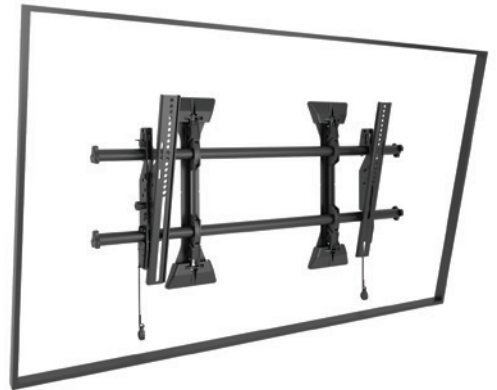

LTA1U 37 - 80" WALL MOUNT



This option without micro height adjustment is ideal for installs using Chief connector kits for multi-display installations.

Weight Capacity	Dimensions (HxWxD)	Mounting Patterns (W,H)	Max Lateral Shift	Height Adjust	Tilt
90.9 kg	419 x 883 x 50.8 mm	100 x 100 - 895 x 505 mm	441 mm	N/A	+2°, -12°

* Available second quarter, 2015. Order first generation LTAU until then.

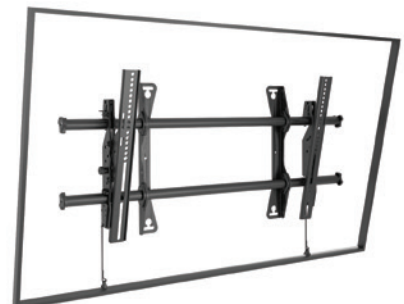

MTM1U 26 - 55" MICRO-ADJUST MOUNT



Simpler install with only two attach points.

Weight Capacity	Dimensions (HxWxD)	Mounting Patterns (W,H)	Max Lateral Shift	Height Adjust	Tilt
56.7 kg	432 x 654 x 51 mm	100 x 100 - 667 x 400 mm	327 mm	25 mm	+2°, -12°

* Available second quarter, 2015. Order first generation MTMU until then.



MTMP1U 26 - 55" PORTRAIT/MICRO-ADJUST



The portrait version of the popular MTMU.

Weight Capacity	Dimensions (HxWxD)	Mounting Patterns (W,H)	Max Lateral Shift	Height Adjust	Tilt
56.7 kg	622 x 530 x 81 mm	100 x 100 - 600 x 460 mm	265 mm	25 mm	+5°, -12°

* Available second quarter, 2015. Order first generation MTMPU until then.



MTA1U 26 - 55" WALL MOUNT



This option without micro height adjustment is ideal for installs using Chief connector kits for multi-display needs.

Weight Capacity	Dimensions (HxWxD)	Mounting Patterns (W,H)	Max Lateral Shift	Height Adjust	Tilt
56.7 kg	419 x 654 x 51 mm	100 x 100 - 673 x 400 mm	327 mm	N/A	+2°, -12°

* Available second quarter, 2015. Order first generation MTAU until then.



FUSION™ TILT MOUNT ACCESSORIES



FCA830/ FCA840+		Compatibility
Center Channel Speaker Adapter		Fusion Fixed & Tilt Wall, Freestanding & Ceiling Mounts
Model	Typical Screen Size	Weight Capacity
FCA830	52 - 80"	9.1 kg
FCA840	70 - 100"+	9.1 kg

* Available spring, 2015.



FCA831/ FCA841+		Compatibility
Center Channel Speaker Adapter		Fusion Fixed & Tilt Wall, Freestanding & Ceiling Mounts
Model	Typical Screen Size	Weight Capacity
FCA831	42 - 70"	4.5 kg/side
FCA841	50 - 95"	4.5 kg/side

* Available spring, 2015.



FLR100	Weight Capacity	Compatibility
Left/Right Speaker Adapter	9.1 kg	Fusion Fixed & Tilt Wall Mounts



FCC100	Weight Capacity	Compatibility
Center Channel Speaker Adapter	9.1 kg	Fusion Landscape Fixed & Tilt Wall Mounts



FCA102	Equipment Depth Range	Compatibility
Secure CPU/Media Player Adapter	0 - 41 mm	Large & Extra Large Fusion Wall Mounts



FCA103	Compatibility
Extension Accessory for Behind-Mount Storage Space	All Fusion Wall Mounts



FCA101	Compatibility
Lock-Down Collar	Fusion Fixed & Tilt Wall Mounts



FCK000/008/016	Compatibility
Connector Kits	Fusion Fixed & Tilt Wall Mounts
Model	Width
FCK000	Adds zero length to the poles
FCK008	203 mm
FCK016	406 mm



FCA800/ FCA801+	Compatibility	
Above/Below Shelf, Large* Displays	Fusion Fixed & Tilt Wall, Freestanding & Ceiling Mounts	
Model	Size	Weight Capacity
FCA800	203 mm	9.1 kg
FCA801	355 mm	9.1 kg

* Typical screen size: 46-70".
* Available second quarter, 2015.



FCA810/ FCA811+	Compatibility	
Above/Below Shelf, XL* Displays	Fusion Fixed & Tilt Wall, Freestanding & Ceiling Mounts	
Model	Size	Weight Capacity
FCA810	203 mm	9.1 kg
FCA811	355 mm	9.1 kg

* Typical screen size: 70-100".
* Available second quarter, 2015.



FCA820/ FCA821+	Compatibility	
Fusion Center Camera Shelf	Fusion Ceiling, Freestanding and Wall Mounts	
Model	Size	Weight Capacity
FCA820	203 mm	9.1 kg
FCA821	355 mm	9.1 kg

* Available second quarter, 2015.

FUSION™ TILT MOUNT ACCESSORIES



FCS100	Dimensions (WxD)	Weight Capacity	Compatibility
Component Shelf	457 x 335 mm	9.1 kg	Fusion Landscape Wall Mounts



FCD100	Compatibility
Stackable Component Shelf	Fusion Landscape Wall Mounts



FCA104	Compatibility
Component Shelf Extender	FCS100, FVS100, FVS150, FCC100, FCD100



FVS100/150	Compatibility	
Video Conference Camera Shelves - Below	Fusion Landscape Wall Mounts	
Model	Shelf Dimensions (WxD)	Weight Capacity
FVS100	203 x 335 mm	4.5 kg
FVS150	305 x 335 mm	4.5 kg



FVS200/250/251	Compatibility	
Video Conference Camera Shelves - Above	Fusion Landscape Wall Mounts	
Model	Shelf Dimensions (WxD)	Weight Capacity
FVS200	203 x 180 mm	4.5 kg
FVS250	305 x 180 mm	4.5 kg
FVS251	356 x 180 mm	4.5 kg







FVS300/350	Compatibility	
Video Conference Camera Shelves - Center	Fusion Fixed & Tilt Wall Mounts	
Model	Shelf Dimensions (WxD)	Weight Capacity
FVS300	203 x 178 mm	4.5 kg
FVS350	305 x 178 mm	4.5 kg



FCA106	Compatibility
Side Cover Accessory	Fusion Fixed & Tilt Wall Mounts

THININSTALL™ TILT MOUNT

FEATURES

- 
ULTRA-LOW PROFILE
 At less than the width of a penny, these mounts provide an ultra-thin profile to showcase any flat-screen display.
- 
GLIDE LOCK
 Tool-less latching with a sliding flag for fast installation.
- 
CENTRIS LOW-PROFILE TILT
 Uses the center of gravity to balance the screen while maintaining a low profile. The display stays set in place until readjusted.
- 
CABLE KICKSTAND
 A kickstand makes cable access hands-free while the open wall plate allows for easy electrical placement behind the display.



GLIDE LOCK™ LATCH



CABLE MANAGEMENT

LTTU 37 - 80" ULTRA-LOW PROFILE



At 19 mm thick, this mount combines an ultra-thin profile with the functionality of 12 degrees of tilt.

Weight Capacity	Dimensions (HxWxD)	Mounting Patterns (W,H)	Max Screen Thickness	Tilt
45.4 kg	548 x 907 x 19 mm	200 x 200 - 800 x 500 mm	51 mm	-12°



MTTU 26 - 55" ULTRA-LOW PROFILE



Like the LTTU but it allows for different mounting patterns and both landscape and portrait screen orientations.

Weight Capacity	Dimensions (HxWxD)	Mounting Patterns (W,H)	Max Screen Thickness	Tilt
45.4 kg	448 x 706 x 19 mm	100 x 100 - 600 x 400 mm	51 mm	-12°



OTHER TILT WALL MOUNTS

MWCU 26 - 55" MOUNT WITH CPU STORAGE



Provides an all-in-one tilt wall mount solution for both a medium-sized flat panel display and CPU or receiver.

Weight Capacity	Dimensions (HxWxD)	Mounting Patterns (W,H)	Max Equip Size (HxWxD)	Tilt
45.4 kg	303 x 487 x 114 mm	100 x 100 - 709 x 431 mm	356 x 478 x 97 mm	-15°



FTRV 10 - 32" WALL MOUNT



A small option for flat panel displays or monitors that allows for portrait or landscape options with Q-Latch™ mounting system.

Weight Capacity	Dimensions (HxWxD)	Mounting Patterns (W,H)	Tilt
20.4 kg	142 x 141 x 46 mm	75 x 75 - 200 x 100 mm	+5°, -15°





VIDEO WALL DISPLAY WALL MOUNTS

CONNEXSYS™ VIDEO WALL SYSTEM FEATURES



SPEED LEVELING

Mount multiple units to a single strut channel for quick row leveling and centerless lateral shift.



POWERZONE™ ADJUSTMENTS

Six points of tool-free adjustment: height, depth, lateral and tilt are all found in one easy-to-access location. Rigid frame keeps displays where you set them even after extending for service.



RAPIDDRAW™ DISPLAY RELEASE

Cord release system gently and remotely pops any screen out 349 mm from the wall for easy access and service while minimizing aggressive screen pushes. Get an additional 20 degrees of bottom pull-out with an integrated kickstand. Cords can be set to release from any 90 degree angle.



GENEROUS DEPTH ADJUSTMENT

Mount depth from wall can be set between 102 and 186 mm for perfect alignment, accommodating for recess applications and wall imperfections.

LVS1U 42 - 80" LANDSCAPE SYSTEM WITH RAILS



This universal pop-out mount is ideal for large-scale, seamless video walls and recessed applications. Ships with rails for each mount.

Weight Capacity	Dimensions (HxWxD)	Mounting Patterns (WxH)	Tilt	Height Adjust	Total Depth Adjust
68 kg	554 x 903 x 102 mm	200 x 100 - 700 x 400 mm*	+4° / -2.5°	± 25 mm	85 mm

* Add CSA110 VESA adapter for compatibility with 800 x 400 mm mounting patterns.

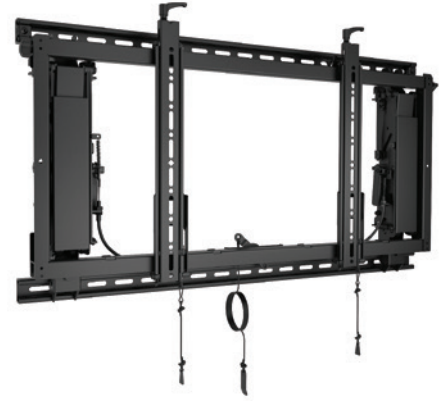

LVS1UP 40 - 80" PORTRAIT SYSTEM WITH RAILS



The portrait version of the LVS1U that ships with rails for each mount.

Weight Capacity	Dimensions (HxWxD)	Mounting Patterns (WxH)	Tilt	Height Adjust	Total Depth Adjust
68 kg	826 x 496 x 104 mm	200 x 100 - 800 x 400 mm	+4° / -2.5°	± 25 mm	85 mm



LVSXU 42 - 80" LANDSCAPE SYSTEM WITHOUT RAILS

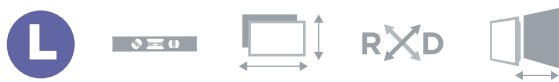

Nearly identical to the LVS1U but ships without rails so installers can source strut locally to hang multiple mounts to one rail and reduce installation time.

Weight Capacity	Dimensions (HxWxD)	Mounting Patterns (WxH)	Tilt	Height Adjust	Total Depth Adjust
68 kg	554 x 903 x 102 mm	200 x 100 - 700 x 400 mm*	+4° / -2.5°	± 25 mm	85 mm

* Add CSA110 VESA adapter for compatibility with 800 x 400 mm mounting patterns.



LVSXUP 40 - 80" PORTRAIT SYSTEM WITHOUT RAILS

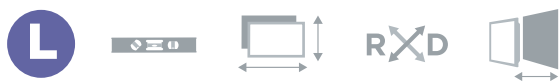





The portrait version of the LVSXU that also ships without rails.

Weight Capacity	Dimensions (HxWxD)	Mounting Patterns (WxH)	Tilt	Height Adjust	Total Depth Adjust
68 kg	826 x 496 x 104 mm	200 x 100 - 800 x 400 mm	+4° / -2.5°	± 25 mm	85 mm



FUSION™ PULL-OUT FEATURES

- 
PULL-OUT EXTENSION
 Mounts extend 178 mm for easy cable access and servicing in hard-to-reach installations.
- 
CONTROLZONE LEVELING
 Post-installation fine-tuning of height and leveling ensures screen will be perfectly aligned.
- 
CENTERLESS SHIFT
 Generous post-installation lateral shift allows screen to slide apart or together for easy maintenance and perfect alignment.
- 
CLICKCONNECT™
 Tool-less latching makes an audible click when a Fusion mount is safely engaged with the screen.

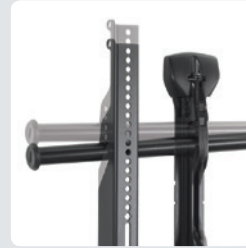

CONTROLZONE™



CENTERLESS™ SHIFT

LSMVU 37 - 63" PULL-OUT WALL MOUNT



Chief's most popular, micro-adjustable pull-out mount fits most displays to create seamless video walls up to 2x2.

Weight Capacity	Dimensions (HxWxD)	Mounting Patterns (W,H)	Max Lateral Shift	Extension	Plumb Adjustment
68 kg	533 x 879 x 94 mm	200 x 200 - 760 x 505 mm	445 mm	272 mm	2.5°

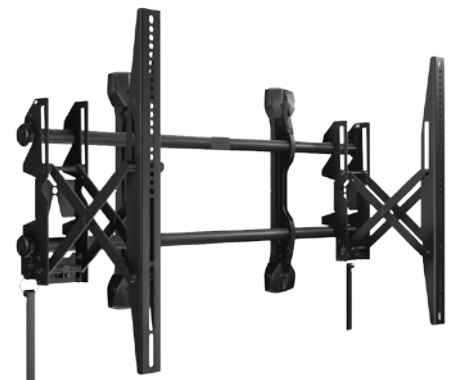

LSMVPU PORTRAIT PULL-OUT WALL MOUNT



The portrait version of the popular LSMVU for 37-63" displays can be used to create video walls up to 2x2.

Weight Capacity	Dimensions (HxWxD)	Mounting Patterns (W,H)	Max Lateral Shift	Extension	Plumb Adjustment
68 kg	826 x 523 x 94 mm	200 x 200 - 800 x 400 mm	102 mm	272 mm	2.5°



MSMVU 26 - 47" PULL-OUT WALL MOUNT



The smaller version of the LSMVU for shorter and/or narrower mounting patterns can be used to create video walls up to 2x2.

Weight Capacity	Dimensions (HxWxD)	Mounting Patterns (W,H)	Max Lateral Shift	Extension	Plumb Adjustment
56.7 kg	419 x 648 x 94 mm	100 x 100 - 540 x 400 mm	368 mm	272 mm	2.5°

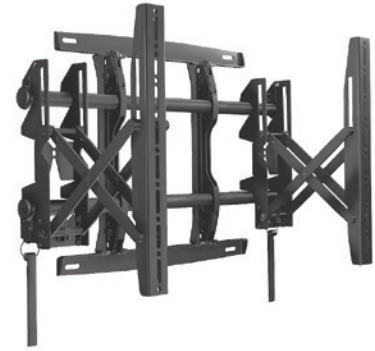

MSMVPU PORTRAIT PULL-OUT WALL MOUNT



The portrait version of the popular MSMVU for 26 - 47" displays can be used to create video walls up to 2x2.

Weight Capacity	Dimensions (HxWxD)	Mounting Patterns (W,H)	Max Lateral Shift	Extension	Plumb Adjustment
56.7 kg	620 x 523 x 94 mm	100 x 100 - 600 x 400 mm	254 mm	272 mm	2.5°



FUSION™ PULL-OUT MOUNT ACCESSORIES



FCA100	Equipment Depth Range	Compatibility
CAT5/Surge/CPU Adapter	0 - 46 mm	Fusion Fixed & Tilt Wall Mounts



FCA102	Equipment Depth Range	Compatibility
Secure CPU/Media Player Adapter	0 - 41 mm	Large & Extra Large Fusion Wall Mounts



FCA101	Compatibility
Lock-Down Collar	Fusion Fixed & Tilt Wall Mounts



FCS100	Dimensions (WxD)	Weight Capacity	Compatibility
Component Shelf	457 x 335 mm	9.1 kg	Fusion Landscape Wall Mounts



FCD100	Compatibility
Stackable Component Shelf	Fusion Landscape Wall Mounts



FCA104	Compatibility
Component Shelf Extender	FCS100, FVS100, FVS150, FCC100, FCD100



FCA800/ FCA801+	Compatibility	
Above/Below Shelf, Large* Displays	Fusion Fixed & Tilt Wall, Freestanding & Ceiling Mounts	
Model	Size	Weight Capacity
FCA800	203 mm	9.1 kg
FCA801	355 mm	9.1 kg

*Typical screen size: 46-70". † Available spring, 2015.



FCA810/ FCA811+	Compatibility	
Above/Below Shelf, XL* Displays	Fusion Fixed & Tilt Wall, Freestanding & Ceiling Mounts	
Model	Size	Weight Capacity
FCA810	203 mm	9.1 kg
FCA811	355 mm	9.1 kg

* Typical screen size: 70-100". † Available spring, 2015.



FCA820/ FCA821+	Compatibility	
Fusion Center Camera Shelf	Fusion Ceiling, Freestanding and Wall Mounts	
Model	Size	Weight Capacity
FCA820	203 mm	9.1 kg
FCA821	355 mm	9.1 kg

† Available spring, 2015.



FVS100/150	Compatibility	
Video Conference Camera Shelves - Below	Fusion Landscape Wall Mounts	
Model	Shelf Dimensions (WxD)	Weight Capacity
FVS100	203 x 335 mm	4.5 kg
FVS150	305 x 335 mm	4.5 kg



FVS200/250/251	Compatibility	
Video Conference Camera Shelves - Above	Fusion Landscape Wall Mounts	
Model	Shelf Dimensions (WxD)	Weight Capacity
FVS200	203 x 180 mm	4.5 kg
FVS250	305 x 180 mm	4.5 kg
FVS251	356 x 180 mm	4.5 kg



FCA830/ FCA840+	Compatibility	
Center Channel Speaker Adapter	Fusion Fixed & Tilt Wall, Freestanding & Ceiling Mounts	
Model	Typical Screen Size	Weight Capacity
FCA830	52 - 80"	9.1 kg
FCA840	70 - 100"+	9.1 kg

† Available spring, 2015.

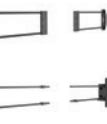

FCA831/ FCA841+	Compatibility	
Center Channel Speaker Adapter	Fusion Fixed & Tilt Wall, Freestanding & Ceiling Mounts	
Model	Typical Screen Size	Weight Capacity
FCA831	42 - 70"	4.5 kg/side
FCA841	50 - 95"	4.5 kg/side

† Available spring, 2015.



SWING ARM DISPLAY WALL MOUNTS

THINSTALL™ SWING ARM FEATURES



ULTRA-LOW PROFILE

These sleek designs retract down to 38 to 46 mm to provide an ultra-thin profile to showcase any flat-screen display.



CENTERLESS™ SHIFT

Generous post-installation lateral shift up to 406 mm allows for perfect display positioning.



CABLE MANAGEMENT

Enclosed, tool-less cable covers and a wide open wall plate make it easy to route power and signal cables.



CENTRIS™ FINGERTIP TILT

Uses the center of gravity to balance the screen for up to 15 degrees of easy tilt capability.



HEIGHT ADJUST

Adjust the height of the entire configuration post installation up to 25 mm.

TS525TU 37 - 58" EXTENDS 635 mm



This feature-rich swing arm fits most screens and has a large array of supporting accessories.

Weight Capacity	Dimensions (HxWxD)	Mounting Patterns (W,H)	Extension	Max Lateral Shift	Tilt	Height Adjust
56.7 kg	527 x 749 x 38 mm	100 x 100 - 800 x 400 mm	635 mm	406 mm	-15°	25 mm



TS325TU 26 - 52" EXTENDS 635 mm



Very similar to the TS525TU but with shorter wall plate and modified interface making it better suited for lighter displays.

Weight Capacity	Dimensions (HxWxD)	Mounting Patterns (W,H)	Extension	Max Lateral Shift	Tilt	Height Adjust
34 kg	439 x 749 x 46 mm	100 x 100 - 600 x 400 mm	635 mm	406 mm	-15°	25 mm



TS318TU 26 - 52" EXTENDS 457 mm



This mount has the same features as the TS325TU with 457 mm extension.

Weight Capacity	Dimensions (HxWxD)	Mounting Patterns (W,H)	Extension	Max Lateral Shift	Tilt	Height Adjust
34 kg	439 x 574 x 46 mm	100 x 100 - 600 x 400 mm	457 mm	406 mm	-15°	25 mm



TS318SU 26 - 52" EXTENDS 457 mm



This single stud version of the TS318 dual arm swing arm mount works well when lateral shift is not a necessity.

Weight Capacity	Dimensions (HxWxD)	Mounting Patterns (W,H)	Extension	Max Lateral Shift	Tilt	Height Adjust
34 kg	343 x 574 x 46 mm	100 x 100 - 600 x 400 mm	457 mm	N/A	-15°	25 mm



TS218SU 26 - 47" EXTENDS 457 mm



This single stud swing arm works well in corners and with most medium flat panels. It also accommodates portrait and landscape orientations.

Weight Capacity	Dimensions (HxWxD)	Mounting Patterns (W,H)	Extension	Max Lateral Shift	Tilt	Height Adjust
34 kg	356 x 330 x 38 mm	100 x 100 - 400 x 400 mm	457 mm	N/A	-12°	25 mm



TS118SU 10 - 32" EXTENDS 457 mm



Fits smaller patterns and screens than the TS218SU.

Weight Capacity	Dimensions (HxWxD)	Mounting Patterns (W,H)	Extension	Max Lateral Shift	Tilt	Height Adjust
15.9 kg	294 x 330 x 38 mm	75 x 75 - 200 x 200 mm	457 mm	N/A	-12°	N/A



TS110SU 10 - 32" EXTENDS 250 mm



This basic swing arm wall mount provides single arm extension and swivel for smaller displays.

Weight Capacity	Dimensions (HxWxD)	Mounting Patterns (W,H)	Extension	Max Lateral Shift	Tilt	Height Adjust
15.9 kg	239 x 356 x 38 mm	75 x 75 - 200 x 200 mm	250 mm	N/A	-12°	N/A



THININSTALL™ SWING ARM ACCESSORIES



TA100	Dimensions (WxD)	Weight Capacity	Compatibility
Component Shelf	457 x 305 mm	4.5 kg	TS525TU, TS325TU, TS318TU, TS318SU



TA200/250		Compatibility
Video Conference Camera Shelves - Above		TS525TU, TS325TU, TS318TU, TS318SU
Model	Dimensions (WxD)	Weight Capacity
TA200	203 x 184 mm	4.5 kg
TA250	305 x 184 mm	4.5 kg



TA300	Weight Capacity	Compatibility
Left/Right Speaker Adapter	4.5 kg	TS525TU, TS325TU, TS318TU, TS318SU



TA350	Weight Capacity	Compatibility
Center Channel Speaker Adapter	4.5 kg	TS525TU, TS325TU, TS318TU, TS318SU



TA410	Compatibility
Portrait Adapter	TS525TU, TS325TU, TS318TU, TS318SU

OTHER SWING ARM MOUNTS

PDRUB 42 - 80" EXTENDS UP TO 940 mm



The heavy-duty swing arm option works for displays up to 90.7 kg and boasts the most extension capabilities at 940 mm.

Weight Capacity	Dimensions (HxWxD)	Mounting Patterns (W,H)	Extension	Max Lateral Shift	Tilt	Color
90.7 kg	56 x 100.3 x 8.6 cm	200 x 200 - 862 x 517 mm	940 mm	229 mm	+5°, -16°	B



PNRUB 42 - 80" EXTENDS UP TO 635 mm



The smaller version of the PDR extends to 635 mm.

Weight Capacity	Dimensions (HxWxD)	Mounting Patterns (W,H)	Extension	Max Lateral Shift	Tilt	Color
90.7 kg	538 x 687 x 84 mm	200 x 200 - 862 x 517 mm	635 mm	229 mm	+5°, -17°	B

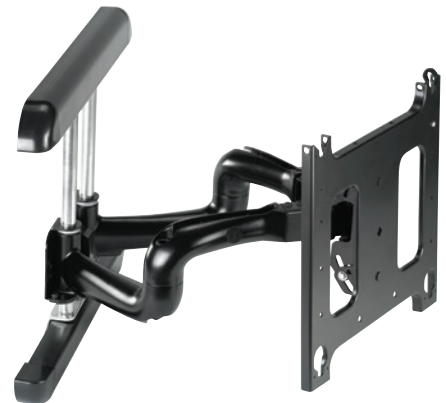

OTHER SWING ARM MOUNT ACCESSORY



PAC715/PAC716		Compatibility
Video Conference Camera Shelves - Above or Below		PDR, PNR & Other Q-Latch Mounts
Model	Dimensions (WxD)	Weight Capacity
PAC715	229 x 223 mm	4.5 kg
PAC716	356 x 201 mm	4.5 kg



PACCS1	Compatibility
Large Accessory Shelf	PDR, PNR & Other Q-Latch Mounts



CEILING DISPLAY MOUNTS

FUSION™ VIDEO WALL FEATURES



CONTROLZONE™ LEVELING
Allows for 51 mm of height adjustment at each mounting box plus 25 mm increments along each column.



INDEPENDENT ADJUSTMENT
Separate knobs for micro-height and plumb adjustment help to easily align displays without tools.



INFINITE SCREEN POSITIONING
Infinite vertical and lateral shift adjustments allow for tight display rows and columns.



CABLE MANAGEMENT
FCACLIPS can be added at any point along the crossbars to create anchor points for easy cable management.



ADD EXTENSION
FCAX accessories increase rail length for larger displays, up to 152 cm.



INDEPENDENT
ADJUSTMENT



INFINITE SCREEN
POSITIONING

LCM3X3U LANDSCAPE VIDEO WALL



The landscape 3 wide x 3 tall configuration can be combined with other ceiling mounts to create longer walls. Fits 40 - 55" displays.

Weight Capacity (per screen)	Dimensions (HxWxD)	Mounting Patterns (W,H)	Manual Height Adjust	Micro Height Adjust
38.5 kg	1996 x 2763 x 368 mm	Any width x 100 - 400 mm	25 mm	51 mm

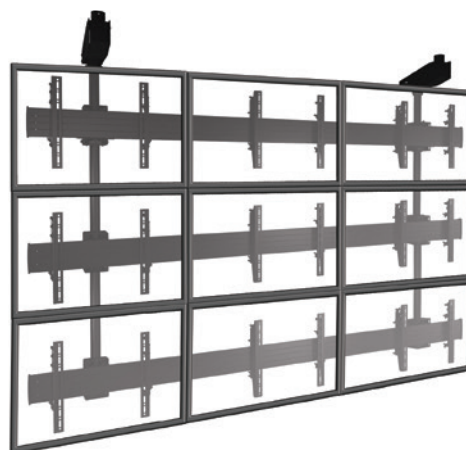

LCM3X2U LANDSCAPE VIDEO WALL



Create video walls in landscape orientation 3 wide x 2 tall. Fits 40 - 55" displays.

Weight Capacity (per screen)	Dimensions (HxWxD)	Mounting Patterns (W,H)	Manual Height Adjust	Micro Height Adjust
56.7 kg	1389 x 2766 x 368 mm	Any width x 100 - 400 mm	25 mm	51 mm

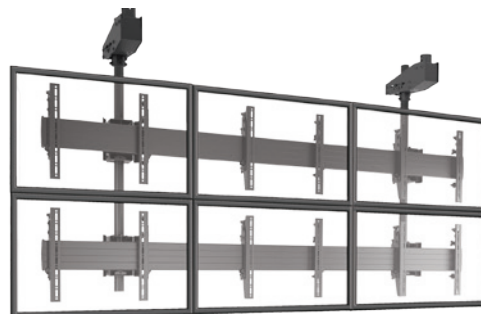

LCM3X2UP PORTRAIT VIDEO WALL



A portrait version to mount video walls 3 wide x 2 tall. Fits 40 - 55" displays.

Weight Capacity (per screen)	Dimensions (HxWxD)	Mounting Patterns (W,H)	Manual Height Adjust	Micro Height Adjust
56.7 kg	1996 x 1748 x 368 mm	100 - 800 mm x Any Height	25 mm	51 mm



LCM2X2U LANDSCAPE VIDEO WALL



The versatile and popular landscape 2 wide x 2 tall configuration fits well in most digital signage applications. Fits 40 - 55" displays.

Weight Capacity (per screen)	Dimensions (HxWxD)	Mounting Patterns (W,H)	Manual Height Adjust	Micro Height Adjust
56.7 kg	1389 x 1851 x 368 mm	Any width x 100 - 400 mm	25 mm	51 mm

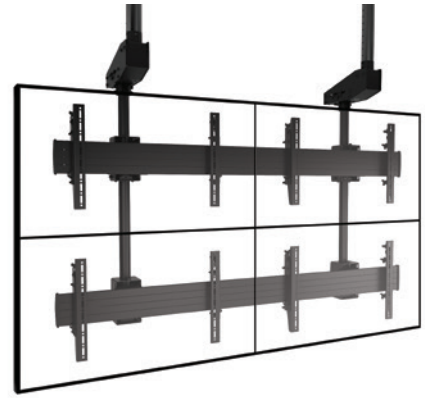

LCM2X2UP PORTRAIT VIDEO WALL







A portrait version to mount video walls 2 wide x 2 tall. Fits 40 - 55" displays.

Weight Capacity (per screen)	Dimensions (HxWxD)	Mounting Patterns (W,H)	Manual Height Adjust	Micro Height Adjust
56.7 kg	1996 x 1189 x 368 mm	100 - 800 mm x Any Height	25 mm	51 mm



FUSION™ MENU BOARD

FEATURES

-  **CONTROLZONE™ LEVELING**
Allows for 51 mm of height adjustment at each mounting box.
-  **CENTRIS™ TILT TECHNOLOGY**
Screens stay where you place them for effortless multi-screen alignment.
-  **TOOL-FREE SCREEN ENGAGEMENT**
Easily place screens and add optional padlock security.
-  **LATERAL SHIFT**
Post-installation lateral shift allows screens to slide apart or together for easy maintenance and perfect alignment.
-  **ADD EXTENSION**
FCAX accessories increase rail length for larger displays, up to 152 cm.



CONTROLZONE LEVELING



CENTRIS TILT TECHNOLOGY

LCM3X1U LANDSCAPE MENU BOARD



This classic menu board configuration is three screens across. Create longer menu boards by combining mounts. Fits 40 - 55" displays.

Weight Capacity (per screen)	Dimensions (HxWxD)	Mounting Patterns (W,H)	Micro Height Adjust	Tilt
56.7 kg	425 x 2766 x 201 mm	Any width x 100 - 400 mm	51 mm	+5°, -20°

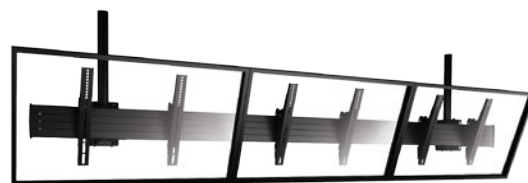

LCM3X1UP PORTRAIT MENU BOARD



The portrait of the LCM3X1U. Fits 40 - 55" displays.

Weight Capacity (per screen)	Dimensions (HxWxD)	Mounting Patterns (W,H)	Micro Height Adjust	Tilt
56.7 kg	826 x 1750 x 201 mm	100 - 800 mm x Any Height	51 mm	+5°, -20°

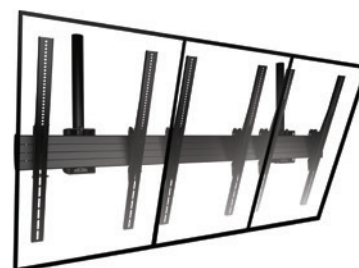

LCB3X1U BACK-TO-BACK LANDSCAPE



Mount three screens back-to-back in landscape orientation for six total screens. Fits 40 - 55" displays.

Weight Capacity (per screen)	Dimensions (HxWxD)	Mounting Patterns (W,H)	Micro Height Adjust	Tilt
56.7 kg	425 x 2763 x 292 mm	Any width x 100 - 400 mm	51 mm	+5°, -20°

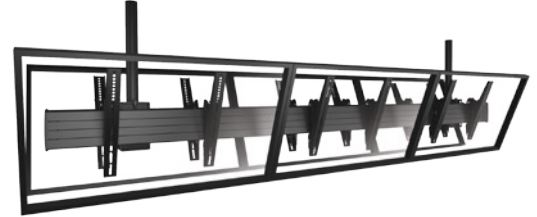

LCB3X1UP BACK-TO-BACK PORTRAIT



The portrait version of the LCB3X1U. Fits 40 - 55" displays.

Weight Capacity (per screen)	Dimensions (HxWxD)	Mounting Patterns (W,H)	Micro Height Adjust	Tilt
56.7 kg	826 x 1748 x 292 mm	100 - 800 mm x Any Height	51 mm	+5°, -20°

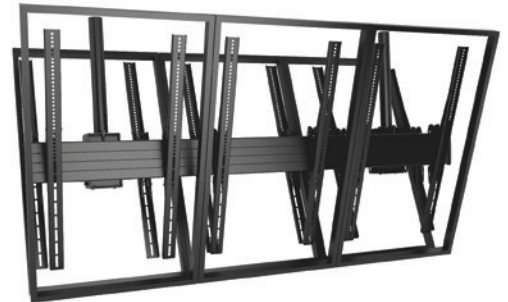

LCM2X1U LANDSCAPE MENU BOARD



This classic menu board configuration is two screens across. Create longer menu boards by combining mounts. Fits 40 - 55" displays.

Weight Capacity (per screen)	Dimensions (HxWxD)	Mounting Patterns (W,H)	Micro Height Adjust	Tilt
56.7 kg	427 x 1851 x 201 mm	Any width x 100 - 400 mm	N/A	+5°, -20°

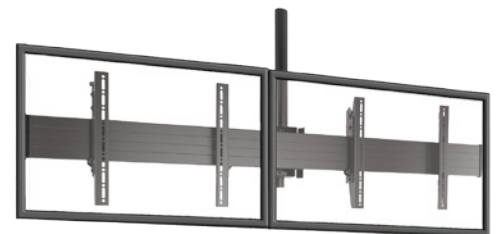

LCM2X1UP PORTRAIT MENU BOARD



The portrait version of the LCM2X1U. Fits 40 - 55" displays.

Weight Capacity (per screen)	Dimensions (HxWxD)	Mounting Patterns (W,H)	Micro Height Adjust	Tilt
56.7 kg	826 x 1190 x 201 mm	100 - 800 mm x Any Height	N/A	+5°, -20°

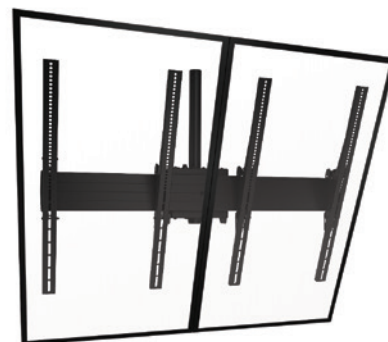

LCB2X1U BACK-TO-BACK LANDSCAPE



Mount two screens back-to-back in landscape orientation for four total screens. Fits 40 - 55" displays.

Weight Capacity (per screen)	Dimensions (HxWxD)	Mounting Patterns (W,H)	Micro Height Adjust	Tilt
45.4 kg	425 x 1851 x 296 mm	Any width x 100 - 400 mm	N/A	+5°, -20°

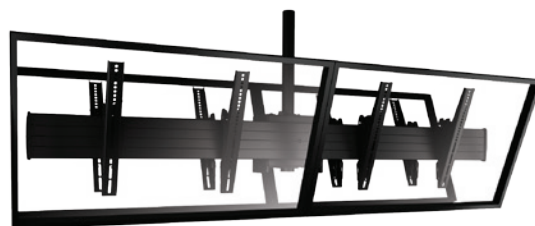

LCB2X1UP BACK-TO-BACK PORTRAIT



The portrait version of the LCB2X1U. Fits 40 - 55" displays.

Weight Capacity (per screen)	Dimensions (HxWxD)	Mounting Patterns (W,H)	Micro Height Adjust	Tilt
45.4 kg	826 x 1190 x 296 mm	100 - 800 mm x Any Height	N/A	+5°, -20°

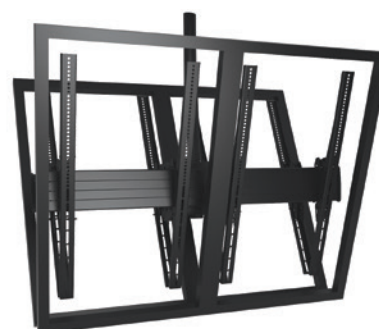

FUSION™ CEILING MOUNTS

FEATURES



CENTRIS™ TILT TECHNOLOGY

Provides a continuous range of fingertip tilt from +5 to -20 degrees with four set locking points at 0, 5, 10 and 15 degrees to eliminate guess work when adjusting multiple screens.



ON/OFF COLUMN CONNECTION

Simple connection for ease of installation and service, particularly when installing in tight corners or near walls.



TOOL-FREE SCREEN ENGAGEMENT

Easily place screens and add optional padlock security.



FLEXIBILITY

Mount swivels to any preferred viewing angle before locking down with set screws.

XCM7000 60 - 98" HEAVY-DUTY MOUNT



Dual pole drop provides needed support for single extra large and deep flat panel displays.



Weight Capacity	Dimensions (HxWxD)	Mounting Patterns (W,H)	Tilt	Roll Adjust
136 kg	425 x 884 x 203 mm	800 x 400 mm	+7.5° / -20°	2" total height adjust at each head assembly

XCB7000 60 - 90" BACK-TO-BACK HEAVY-DUTY MOUNT



Dual pole drop provides needed support for back-to-back configurations of extra large and deep flat panel displays.



Weight Capacity (per screen)	Dimensions (HxWxD)	Mounting Patterns (W,H)	Tilt	Roll Adjust
136 kg	425 x 884 x 300 mm	800 x 400 mm	+7.5° / -20°	2" total height adjust at each head assembly

XCM1U 60 - 90" LANDSCAPE CEILING MOUNT



For heavier displays with wider mounting patterns.

Weight Capacity	Dimensions (HxWxD)	Mounting Patterns (W,H)	Tilt	Roll Adjust
113.4 kg	425 x 884 x 201 mm	200 x 100 - 800 x 400 mm	+5°, -20°	±3°

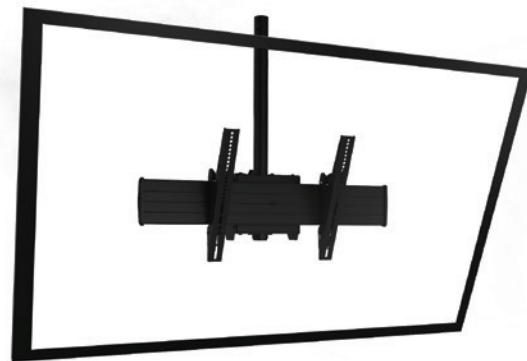

XCB1U 60 - 90" BACK-TO-BACK LANDSCAPE MOUNT



Back-to-back version of the XCM1U to mount two displays with wider mounting patterns.

Weight Capacity (per screen)	Dimensions (HxWxD)	Mounting Patterns (W,H)	Tilt	Roll Adjust
90.7 kg	425 x 884 x 296 mm	200 x 100 - 800 x 400 mm	+5°, -20° for screens up to 38.8" tall	±3°

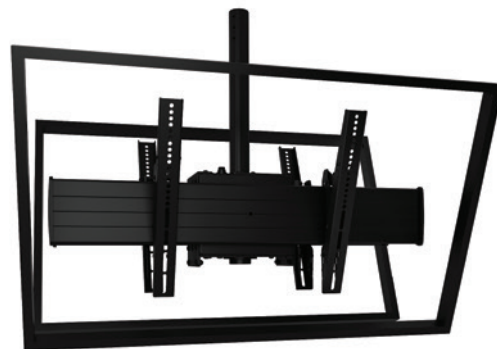

LCM1U LANDSCAPE CEILING MOUNT



Our most popular, feature-packed and versatile single ceiling mount fits most 32 - 60" displays. Add another for stacked configurations.

Weight Capacity	Dimensions (HxWxD)	Mounting Patterns (W,H)	Tilt	Roll Adjust	Color
56.7 kg	420 x 681 x 162 mm	200 x 100 - 616 x 400 mm	+5°, -20°	±3°	S B

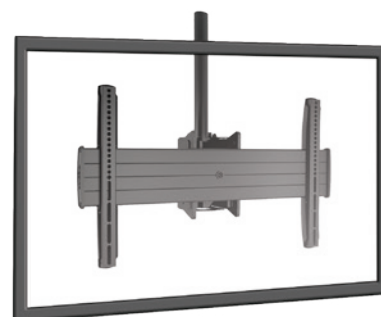

LCM1UP PORTRAIT CEILING MOUNT



The portrait version of the LCM1U. Fits 32 - 60" displays.

Weight Capacity	Dimensions (HxWxD)	Mounting Patterns (W,H)	Tilt	Roll Adjust	Color
56.7 kg	826 x 529 x 162 mm	200 x 100 - 460 x 800 mm	+5°, -20°	±3°	S B

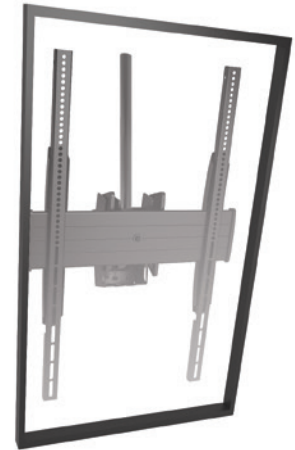

LCB1U BACK-TO-BACK LANDSCAPE MOUNT



The back-to-back version of the LCM1U for two total screens in a landscape configuration. Fits 32 - 60" displays.

Weight Capacity (per screen)	Dimensions per mount (HxWxD)	Mounting Patterns (W,H)	Tilt	Roll Adjust	Color
56.7 kg	420 x 681 x 259 mm	200 x 100 - 616 x 400 mm	+5°, -20°	±3°	B

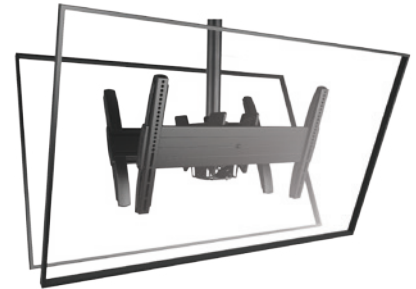

LCB1UP BACK-TO-BACK PORTRAIT MOUNT



The portrait version of the LCB1U. Fits 32 - 60" displays.

Weight Capacity (per screen)	Dimensions per mount (HxWxD)	Mounting Patterns (W,H)	Tilt	Roll Adjust	Color
56.7 kg	826 x 529 x 259 mm	200 x 100 - 460 x 800 mm	+5°, -20°	±3°	B



LCM1X2U 32 - 60" STACKED LANDSCAPE



This solution includes two LCM1U mounts and a 121.9 cm perforated CPA column for stacking two screens on the same column.

Weight Capacity (per screen)	Dimensions per mount (HxWxD)	Mounting Patterns (W,H)	Tilt	Roll Adjust	Color
56.7 kg	420 x 681 x 162 mm	200 x 100 - 616 x 400 mm	+5°, -20°	±3°	B

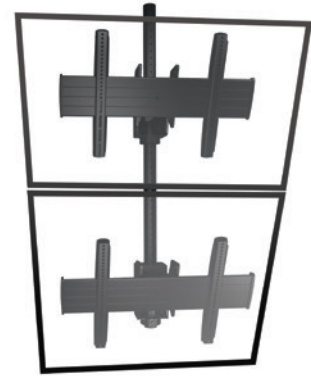

LCB1X2U 32 - 60" BACK-TO-BACK STACKED



The back-to-back version of the LCM1x2U stacks two screens per side for four total screens and a 121.9 cm perforated CPA column.

Weight Capacity (per screen)	Dimensions per mount (HxWxD)	Mounting Patterns (W,H)	Tilt	Roll Adjust	Color
45.3 kg	420 x 681 x 259 mm	200 x 100 - 616 x 400 mm	+5°, -20°	±3°	B



LCM4U 32 - 65" QUAD MOUNT



Allows four screens to be installed on a single column drop for 360° viewing capabilities. Comes with Fusion interfaces.

Weight Capacity (per screen)	Dimensions per mount (HxWxD)	Mounting Patterns (W,H)	Tilt	Roll Adjust	Color
38 kg	475 x 1422 x 1422 mm	200 x 200 - 600 x 400 mm	+5°, -20°	±3°	B

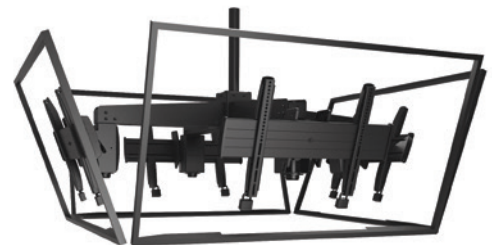

LCM3U 32 - 65" TRIPLE MOUNT



Allows three screens to be installed on a single column drop for 360° viewing capabilities. Comes with Fusion interfaces.

Weight Capacity (per screen)	Dimensions per mount (HxWxD)	Mounting Patterns (W,H)	Tilt	Roll Adjust	Color
57 kg	462 x 1184 x 1184 mm	200 x 200 - 600 x 400 mm	+5°, -20°	±3°	B

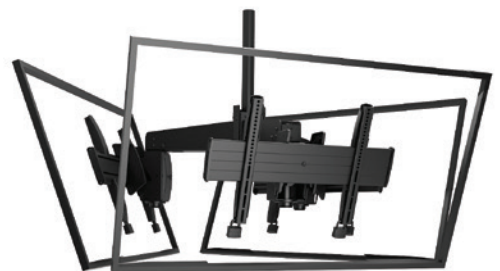

MCM1U 26 - 50" CEILING MOUNT



The medium version of the LCM1U accommodates smaller mounting patterns as well as portrait and landscape orientations.

Weight Capacity	Dimensions (HxWxD)	Mounting Patterns (W,H)	Tilt	Roll Adjust	Color
56.7 kg	420 x 529 x 162 mm	200 x 100 - 460 x 400 mm	+5°, -20°	±3°	S B



MCB1U 26 - 50" BACK-TO-BACK LANDSCAPE



Back-to-back version of the MCM1U for two total screens in landscape or portrait configurations. Fits 26 - 50" displays.

Weight Capacity (per screen)	Dimensions per mount (HxWxD)	Mounting Patterns (W,H)	Tilt	Roll Adjust	Color
56.7 kg	419 x 529 x 259 mm	200 x 100 - 460 x 400 mm	+5°, -20°	±3°	B



MCM1X2U 26 - 50" STACKED LANDSCAPE



Stacked solution includes two MCM1U mounts and a 121.9 cm perforated CPA in a 1 wide x 2 tall configuration.

Weight Capacity (per screen)	Dimensions per mount (HxWxD)	Mounting Patterns (W,H)	Tilt	Roll Adjust	Color
56.7 kg	419 x 529 x 162 mm	200 x 100 - 460 x 400 mm	+5°, -20°	±3°	B



MCB1X2U 26 - 50" BACK-TO-BACK STACKED



Back-to-back version of the MCM1x2U stacks two screens per side for four total screens and a 121.9 cm perforated CPA column.

Weight Capacity (per screen)	Dimensions per mount (HxWxD)	Mounting Patterns (W,H)	Tilt	Roll Adjust	Color
45.3 kg	420 x 529 x 259 mm	200 x 100 - 460 x 400 mm	+5°, -20°	±3°	B



FUSION™ VIDEO WALL, MENU BOARD & CEILING MOUNT ACCESSORIES



FCAX08/14/20		Compatibility
Video Wall Extension Brackets		Fusion Video Wall & Menu Board Ceiling Mounts
Model	Length	
FCAX08	203 mm	
FCAX14	356 mm	
FCAX20	508 mm	



FCAC		Compatibility
Menu Board Connector*		Fusion Ceiling-Mounted Menu Boards

* For alignment and aesthetics only - not for bearing load.



FCA3U		Compatibility
Triple Ceiling Mount Adapter		Allowing for integration of different mount heads like the LCM1U, MCM1U, RLC1, RMC1 and JHS mounts



FCA4U		Compatibility
Quad Ceiling Mount Adapter		Allowing for integration of different mount heads like the LCM1U, MCM1U, RLC1, RMC1 and JHS mounts



FCA500	Shelf Dim. (WxD)	Weight Capacity	Compatibility
Component / Video Conference Shelf - Below	457 x 287 mm	9.1 kg	Fusion Landscape Ceiling & Freestanding Mounts



FCA501/502		Compatibility
Component / Video Conference Shelves - Above		Fusion Landscape Ceiling & Freestanding Mounts
Model	Shelf Dimensions (WxD)	Weight Capacity
FCA501	356 x 254 mm	4.5 kg
FCA502	203 x 254 mm	4.5 kg



FCA800/ FCA801*		Compatibility
Above/Below Shelf, Large* Displays		Fusion Fixed & Tilt Wall, Freestanding & Ceiling Mounts
Model	Size	Weight Capacity
FCA800	203 mm	9.1 kg
FCA801	355 mm	9.1 kg

* Typical screen size: 46-70".
* Available spring, 2015.



FCA810/ FCA811*		Compatibility
Above/Below Shelf, XL* Displays		Fusion Fixed & Tilt Wall, Freestanding & Ceiling Mounts
Model	Size	Weight Capacity
FCA810	203 mm	9.1 kg
FCA811	355 mm	9.1 kg

* Typical screen size: 70-100".
* Available spring, 2015.



FCA820/ FCA821*		Compatibility
Fusion Center Camera Shelf		Fusion Ceiling, Freestanding and Wall Mounts
Model	Size	Weight Capacity
FCA820	203 mm	9.1 kg
FCA821	355 mm	9.1 kg

* Available spring, 2015.



FCA510/515		Compatibility
Storage Accessories		All Fusion Ceiling & Freestanding Mounts
Model	Dimensions (HxWxD)	
FCA510	267 x 267 x 76 mm	
FCA515	394 x 394 x 114 mm	

FUSION™ VIDEO WALL, MENU BOARD & CEILING MOUNT ACCESSORIES



FCA520	Max Equipment Depth	Compatibility
Universal Clamp Kit (Qty 2)	83 mm	All Fusion Ceiling & Freestanding Mounts



FCACLIPS	Compatibility
Anchor Points for Zip Ties (Qty 10)	All Fusion Ceiling & Freestanding Mounts



FCA530	Weight Capacity	Compatibility
Center Channel Speaker Adapter	9.1 kg	Fusion Landscape Ceiling & Freestanding Mounts



FCA830/ FCA840*	Compatibility	
Center Channel Speaker Adapter	Fusion Fixed & Tilt Wall, Freestanding & Ceiling Mounts	
Model	Typical Screen Size	Weight Capacity
FCA830	52 - 80"	9.1 kg
FCA840	70 - 100"+	9.1 kg

* Available spring, 2015.



FCA535	Weight Capacity	Compatibility
Left/Right Speaker Adapters	4.5 kg per side	All Fusion Ceiling & Freestanding Mounts



FCA831/ FCA841*	Compatibility	
Center Channel Speaker Adapter	Fusion Fixed & Tilt Wall, Freestanding & Ceiling Mounts	
Model	Typical Screen Size	Weight Capacity
FCA831	42 - 70"	4.5 kg/side
FCA841	50 - 95"	4.5 kg/side

* Available spring, 2015.

THREADED COLUMN CEILING ACCESSORIES



CMS115		Weight Capacity
Speed-Connect Ceiling Plate		226.8 kg
Model	Color	
CMS115	B (shown)	
CMS115W	W	



CMA330		Weight Capacity
Offset Ceiling Plate - 203 mm		226.8 kg



CMA345		Weight Capacity
Shock Absorption Ceiling Plate		226.8 kg



CMA395		Weight Capacity
Angled Ceiling Plate		226.8 kg
Model	Color	
CMA395	B (shown)	
CMA395W	W	



CMA360		Weight Capacity
I-Beam Clamp		113.4 kg



CMA365		Weight Capacity
Truss Ceiling Adapter		113.4 kg



CMA351		Weight Capacity
Heavy Duty Swivel Adapter		226.8 kg



CMA274/275		Compatibility
Quick-Snap Cable Covers (Qty 1 / 3)		1-1/2" & 2" NPT Columns



CMS Fixed Columns				Weight Capacity
Fixed 1-1/2" NPT extension columns available in black and white†				226.8 kg
Model	Length	Model	Length	
CMS003*	76 mm	CMS018	457 mm	
CMS006*	152 mm	CMS024	0.6 m	
CMS009	229 mm	CMS036	0.9 m	
CMS012	305 mm			

* Steel construction. † All part numbers listed are black. To order white add a W to the end of the part number.



CMS Adjustable Columns				Weight Capacity
Adjustable 1-1/2" NPT extension columns available in black and white†				226.8 kg
Model	Length	Model	Length	
CMS006009	152-229 mm	CMS0203	0.6-0.9 m	
CMS009012	229-305 mm	CMS0305	0.9-1.5 m	
CMS012018	305-457 mm	CMS0406	1.2-1.8 m	
CMS018024	457-610 mm	CMS0507	1.5-2.1 m	

* Cannot ship by UPS due to length. † All part numbers listed are black. To order white add a W to the end of the part number.



CMA640		Compatibility
Decorative Ring, 48 mm ID		1-1/2" NPT & CPA Columns
Model	Color	
CMA640	C (shown)	
CMA640B	B	
CMA640W	W	



CMA643	Compatibility	Color
Decorative Ring, 62 mm ID	CMS Outer Adjustable Columns	S

CPA PIN CONNECTION ACCESSORIES



CPA330	Weight Capacity
CPA Offset Ceiling Plate	226.8 kg



CPA395	Weight Capacity
CPA Angled Ceiling Plate	226.8 kg



CPA365	Weight Capacity
CPA Truss Adapter	226.8 kg



CPA262	Weight Capacity
CPA to NPT Column Connection Adapter (contains male 1-1/2" NPT threads and accepts Chief CPA columns)	226.8 kg
Model	Color
CPA262	B (shown)
CPA262S	S



CPA263	Weight Capacity
CPA column to CPA column connector	226.8 kg



CPA264	Weight Capacity
NPT to CPA Column Connection Adapter (contains female 1-1/2" NPT threads and accepts Chief's CPA columns)	226.8 kg



CPA Columns	Weight Capacity
Fixed, pin-connection extension columns available in black, silver and white†	226.8 kg
Model	Length
CPAE030	300 mm
CPAE080	800 mm
CPAE100	1000 mm
CPAE150	1500 mm
CPAE300	3000 mm
† All part numbers listed are black. To order alternate colors add an S (silver) or W (white) to the end of the part number.	



CMA274	Compatibility
Quick-Snap Cable Cover	CPA Columns



CMA275	Compatibility
Quick-Snap Cable Covers (3 pack)	CPA Columns



AUTOMATED CEILING LIFT FEATURES



CONTROL OPTIONS

Multiple control options include serial communication, dry contact control and IR remote (included).



SMOOTH EXTENSION

Fast and quiet travel at more than 51 mm per second with preset viewing positions.



CLICKCONNECT™

Hear an audible click when the screen engages with the mount. Easy to connect/disconnect - no tools needed!



CABLE MANAGEMENT

Unique cable management system allows cables to move freely with the lift.



CONTROL OPTIONS



SMOOTH EXTENSION

CM2C40UI 32 - 61" CEILING LIFT



Chief's automated ceiling lift with multiple control options including serial communication, dry contact control and IR remote.

Weight Capacity	Dimensions (HxWxD)	Mounting Patterns (W,H)	Max Extension	Overall Travel	Compatibility
86.2 kg	794 x 603 x 197 mm	200 x 200 - 862 x 517 mm	1800 mm	1020 mm	230VAC, 50Hz



OTHER CEILING, TRUSS & POLE MOUNTS

TPSU 42 - 71" FIXED TRUSS & POLE MOUNT



This fixed solution for truss and pole mounting supports portrait and landscape orientations with the Q-Latch™ mounting system.

Weight Capacity	Dimensions (HxWxD)	Mounting Patterns (W,H)	Truss Systems	Orientation
68 kg	412 x 433 x 27 mm	200 x 200 - 862 x 517 mm	356 mm (OD)	Landscape, Portrait



TPMU 42 - 71" TILT POLE MOUNT



Mounts to poles with multiple tilt adjustment options along with portrait and landscape orientations with Q-Latch™ mounting system.

Weight Capacity	Dimensions (HxWxD)	Mounting Patterns (W,H)	Tilt	Tilt Locking Points	Orientation
68 kg	412 x 433 x 86 mm	200 x 200 - 862 x 517 mm	±15°	0°, 5°, 10° and 15°	Landscape, Portrait



JPPU 26 - 45" PIVOT/TILT POLE MOUNT



Pole clamp supports portrait and landscape orientations with Centris™ fingertip tilt in all directions.

Weight Capacity	Dimensions (HxWxD)	Mounting Patterns (W,H)	Pivot/Tilt	Pole Diameter	Color
34 kg	189 x 152 x 89 mm	100 x 100 - 400 x 400 mm	±15°	38 - 51 mm	S B



OTHER CEILING MOUNT ACCESSORIES



PAC715/716		Compatibility
Video Conferencing Camera Shelves - Above or Below		TPS, TPM, TPP & Other Q-Latch Mounts
Model	Dimensions (WxD)	Weight Capacity
PAC715	229 x 223 mm	4.5 kg
PAC716	356 x 301 mm	4.5 kg



IR10	Compatibility
Infrared Remote Control	CM2C40, CM2L40



PAC102	Compatibility
Component Pole Shelf	1-1/2" NPT and CPA Columns



FREESTANDING DISPLAY MOUNTS

FUSION™ VIDEO WALL FEATURES



INDEPENDENT, TOOL-FREE ADJUSTMENT

Separate knobs for micro-height and plumb adjustment help to easily align displays without tools.



CONTINUOUS ADJUSTMENT

Continuous vertical and lateral adjustments allow for tight display rows and columns.



CABLE MANAGEMENT

FCACLIPS can be added at any point along the crossbars to create anchor points for easy cable management.



INSTALLATION OPTIONS

Configurations come in cart or bolt-down applications to meet temporary or permanent signage needs.



ADD EXTENSION

FCAX accessories increase rail length for larger displays, up to 60" (152 cm).



INDEPENDENT
ADJUSTMENT

LVM3X3U 42 - 46" LANDSCAPE CART



The landscape-oriented, 3 wide x 3 tall configuration with smooth rolling casters for large, temporary video walls.

Weight Capacity (per screen)	Dimensions (HxWxD)	Mounting Patterns (W,H)	Height Adjust (per screen)	Plumb Adjust
45.4 kg	2350 x 2743 x 1026 mm	Any Width x 100 - 400 mm	19 mm	19 mm



LBM3X3U 42 - 46" LANDSCAPE BOLT-DOWN



The landscape-oriented, 3 wide x 3 tall configuration for large, bolt-down video walls.

Weight Capacity (per screen)	Dimensions (HxWxD)	Mounting Patterns (W,H)	Height Adjust (per screen)	Plumb Adjust
45.4 kg	2310 x 2763 x 2394 mm	Any Width x 100 - 400 mm	19 mm	19 mm

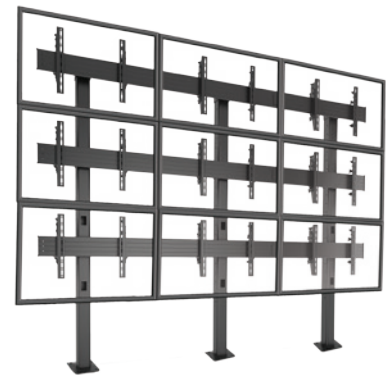

LVM3X2U 42 - 46" LANDSCAPE CART



The landscape-oriented, 3 wide x 2 tall configuration with smooth rolling casters for large, temporary video walls.

Weight Capacity (per screen)	Dimensions (HxWxD)	Mounting Patterns (W,H)	Height Adjust (per screen)	Plumb Adjust
56.7 kg	1893 x 2743 x 1026 mm	Any Width x 100 - 400 mm	19 mm	19 mm

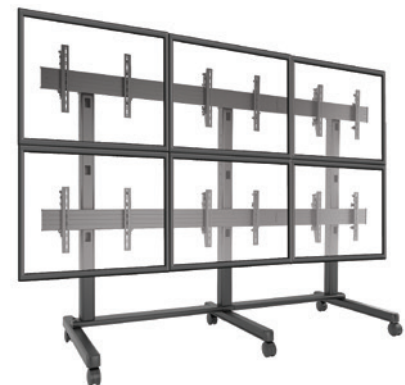

LVM3X2UP 42 - 46" PORTRAIT CART



The portrait version of the LVM3X2U.

Weight Capacity (per screen)	Dimensions (HxWxD)	Mounting Patterns (W,H)	Height Adjust (per screen)	Plumb Adjust
45.4 kg	2710 x 1727 x 1026 mm	100 - 800 mm x Any Height	19 mm	19 mm



LBM3X2U 42 - 46" LANDSCAPE BOLT-DOWN

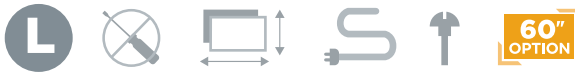

The landscape-oriented, 3 wide x 2 tall configuration for large, bolt-down video walls.

Weight Capacity (per screen)	Dimensions (HxWxD)	Mounting Patterns (W,H)	Height Adjust (per screen)	Plumb Adjust
56.7 kg	1852 x 2766 x 239 mm*	Any Width x 100 - 400 mm	19 mm	19 mm

* Height is increased with FCABX accessories.

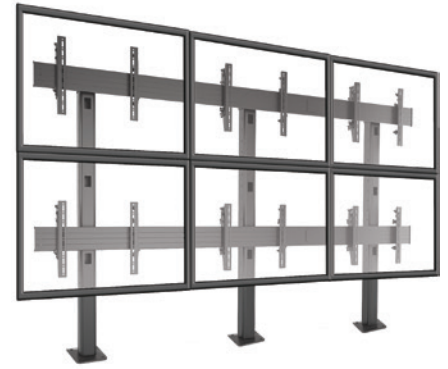

LBM3X2UP 42 - 46" PORTRAIT BOLT-DOWN



The portrait version of the LBM3X2U.

Weight Capacity (per screen)	Dimensions (HxWxD)	Mounting Patterns (W,H)	Height Adjust (per screen)	Plumb Adjust
45.4 kg	2504 x 1727 x 244 mm*	100 - 800 mm x Any Height	19 mm	19 mm

* Height is increased with FCABX accessories.



LVM3X1UP 42 - 46" PORTRAIT CART

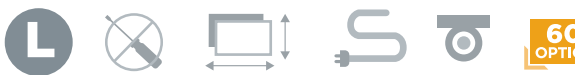

The portrait-oriented, 3 wide x 1 tall configuration with smooth rolling casters for temporary menu boards.

Weight Capacity (per screen)	Dimensions (HxWxD)	Mounting Patterns (W,H)	Height Adjust (per screen)	Plumb Adjust
56.7 kg	2253 x 1727 x 1026 mm	100 - 800 mm x Any Height	19 mm	19 mm



LBM3X1UP 42 - 46" PORTRAIT BOLT-DOWN



The portrait-oriented, 3 wide x 1 tall configuration for bolt-down menu boards.

Weight Capacity (per screen)	Dimensions (HxWxD)	Mounting Patterns (W,H)	Height Adjust (per screen)	Plumb Adjust
56.7 kg	2047 x 1727 x 244 mm*	100 - 800 mm x Any Height	19 mm	19 mm

* Height is increased with FCABX accessories.



LVM2X2U 42 - 50" LANDSCAPE CART



Our top performing, landscape-oriented, 2 wide x 2 tall configuration with smooth rolling casters for large, temporary video walls.

Weight Capacity (per screen)	Dimensions (HxWxD)	Mounting Patterns (W,H)	Height Adjust (per screen)	Plumb Adjust
56.7 kg	2045 x 1842 x 1026 mm	Any Width x 100 - 400 mm	19 mm	19 mm



LVM2X2UP 42 - 50" PORTRAIT CART



The portrait version of the LVM2X2U.

Weight Capacity (per screen)	Dimensions (HxWxD)	Mounting Patterns (W,H)	Height Adjust (per screen)	Plumb Adjust
45.4 kg	2710 x 1168 x 1026 mm	100 - 800 mm x Any Height	19 mm	19 mm



LBM2X2U 42 - 50" LANDSCAPE BOLT-DOWN

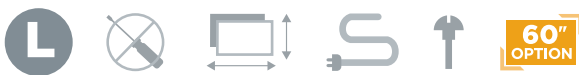

The landscape-oriented, 2 wide x 2 tall configuration for bolt-down video walls.

Weight Capacity (per screen)	Dimensions (HxWxD)	Mounting Patterns (W,H)	Height Adjust (per screen)	Plumb Adjust
56.7 kg	1852 x 1852 x 239 mm*	Any Width x 100 - 400 mm	19 mm	19 mm

* Height is increased with FCABX accessories.



LBM2X2UP 42 - 50" PORTRAIT BOLT-DOWN



The portrait version of the LBM2X2U.

Weight Capacity (per screen)	Dimensions (HxWxD)	Mounting Patterns (W,H)	Height Adjust (per screen)	Plumb Adjust
45.4 kg	2504 x 1168 x 240 mm*	100 - 800 mm x Any Height	19 mm	19 mm

* Height is increased with FCABX accessories.



FUSION™ VIDEO WALL ACCESSORIES

60" OPTION



FCAX08/14/20		Compatibility
Video Wall Extension Brackets		Fusion Video Wall & Menu Board Ceiling Mounts
Model	Length	
FCAX08	203 mm	
FCAX14	356 mm	
FCAX20	508 mm	

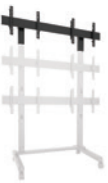

FCA2X1U		Compatibility
LVM & LBM 2x1 Accessory		LVM2X2U, LBM2X2U



FCA3X1U		Compatibility
LVM & LBM 3x1 Accessory		LVM3X2U, LBM3X2U



FCABX18		Compatibility
Fusion LBM Video Wall Height Extensions - 457 mm (18")		Fusion LBM Bolt-Down Mounts



FCABX36		Compatibility
Fusion LBM Video Wall Height Extensions - 914 mm (36")		Fusion LBM Bolt-Down Mounts



FCA500	Dimensions (WxD)	Weight Capacity	Compatibility
Component / Video Conference Shelf - Below	457 x 287 mm	9.1 kg	Fusion Landscape Ceiling & Freestanding Mounts



FCA501/502		Compatibility
Component / Video Conference Shelves - Above		Fusion Landscape Ceiling & Freestanding Mounts
Model	Dimensions (WxD)	Weight Capacity
FCA501	356 x 254 mm	4.5 kg
FCA502	203 x 254 mm	4.5 kg



FCA800/ FCA801*		Compatibility
Above/Below Shelf, Large* Displays		Fusion Fixed & Tilt Wall, Freestanding & Ceiling Mounts
Model	Size	Weight Capacity
FCA800	203 mm	9.1 kg
FCA801	355 mm	9.1 kg

*Typical screen size: 46-70".
 † Available spring, 2015.



FCA810/ FCA811*		Compatibility
Above/Below Shelf, XL* Displays		Fusion Fixed & Tilt Wall, Freestanding & Ceiling Mounts
Model	Size	Weight Capacity
FCA810	203 mm	9.1 kg
FCA811	355 mm	9.1 kg

* Typical screen size: 70-100".
 † Available spring, 2015.



FCA820/ FCA821*		Compatibility
Fusion Center Camera Shelf		Fusion Ceiling, Freestanding and Wall Mounts
Model	Size	Weight Capacity
FCA820	203 mm	9.1 kg
FCA821	355 mm	9.1 kg

† Available spring, 2015.

FUSION™ VIDEO WALL ACCESSORIES



FCA510/515		Compatibility
Storage Accessories		All Fusion Ceiling & Freestanding Mounts
Model	Dimensions (HxWxD)	
FCA510	267 x 267 x 76 mm	
FCA515	394 x 394 x 114 mm	



FCA520	Max Equipment Depth	Compatibility
Universal Clamp Kit (Qty 2)	83 mm	All Fusion Ceiling & Freestanding Mounts



FCA530	Weight Capacity	Compatibility
Center Channel Speaker Adapter	9.1 kg	Fusion Landscape Ceiling & Freestanding Mounts



FCA830/ FCA840+		Compatibility
Center Channel Speaker Adapter		Fusion Fixed & Tilt Wall, Freestanding & Ceiling Mounts
Model	Typical Screen Size	Weight Capacity
FCA830	52 - 80"	9.1 kg
FCA840	70 - 100"+	9.1 kg

* Available spring, 2015.



FCA535	Weight Capacity	Compatibility
Left/Right Speaker Adapters	4.5 kg per side	All Fusion Ceiling & Freestanding Mounts



FCA831/ FCA841+		Compatibility
Center Channel Speaker Adapter		Fusion Fixed & Tilt Wall, Freestanding & Ceiling Mounts
Model	Typical Screen Size	Weight Capacity
FCA831	42 - 70"	4.5 kg/side
FCA841	50 - 95"	4.5 kg/side

* Available spring, 2015.







FCACLIPS	Compatibility
Cable Quick Ties (Qty 10)	All Fusion Ceiling & Freestanding Mounts



FCA776	Compatibility
LVM Leveling Feet	Fusion LVM Video Wall Mounts

FUSION™ CARTS & STANDS

FEATURES

-  **HEIGHT ADJUST**
Turn knob allows a single user to raise or lower the viewing height of the screen by hand or power drill.
-  **CABLE MANAGEMENT**
Flexible cable covers allow access at any point along the column while concealing cables for a clean installation.
-  **CUSTOMIZABLE**
A host of available accessories allows for customized solutions to meet any need.
-  **LOCKING CASTORS**
Smooth rolling and lockable castors make transportation and positioning easy.

XVAU 37 - 70" VIDEO CONFERENCE CART



Aesthetically designed cart with two-toned finish ships fully assembled with 11 RUs of storage space for rack mountable and non-rack mountable AV components. Dual display adapter available, see page 81.

Weight Capacity	Dimensions (HxWxD)	Mounting Patterns (WxH)	Center of Display to Floor Range	Tilt	Color
113 kg	1395 x 986 x 737 mm	200 x 200 - 800 x 400 mm	1064 - 1280 mm	±2.5°	

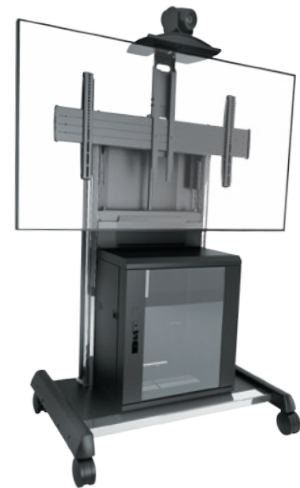

XPAU 55 - 100"+ HEAVY-DUTY CART



Includes a built-in 2U rack space for AV equipment while supporting heavy displays up to 136 kg. Great for video conferencing when used with the dual display accessory. Dual display adapter available, see page 81.

Weight Capacity	Dimensions (HxWxD)	Mounting Patterns (W,H)	Center of Display to Floor Range	Tilt	Color
136 kg	1877 x 1472 x 878 mm	200 x 200 - 800 x 400 mm	1213 - 1662 mm	±5°	



LPAU 40 - 80" HEIGHT-ADJUSTABLE CART



This popular, aesthetically designed cart works well in classrooms and corporate environments.

Weight Capacity	Dimensions (HxWxD)	Mounting Patterns (W,H)	Center of Display to Floor Range	Tilt	Color
90.7 kg	1801 x 1143 x 844 mm	200 x 200 - 800 x 400 mm	1271 x 1779 mm	±5°	S B



LFAU 40 - 80" HEIGHT-ADJUSTABLE STAND



The stand version of the LPAU for semi-permanent installations.

Weight Capacity	Dimensions (HxWxD)	Mounting Patterns (W,H)	Height Adjust	Tilt	Color
90.7 kg	1839 x 968 x 777 mm	200 x 200 - 800 x 400 mm	1130 - 1640 mm	±5°	S B



MPAU 37 - 55" HEIGHT-ADJUSTABLE CART



A smaller version of the LPAU for narrower and shorter mounting patterns.

Weight Capacity	Dimensions (HxWxD)	Mounting Patterns (W,H)	Center of Display to Floor Range	Tilt	Color
56.7 kg	1979 x 1214 x 813 mm	200 x 100 - 600 x 400 mm	1270 - 1770 mm	±5°	S B



MFAU 37 - 55" HEIGHT-ADJUSTABLE STAND



A smaller version of the LFAU for narrower and shorter mounting patterns.

Weight Capacity	Dimensions (HxWxD)	Mounting Patterns (W,H)	Center of Display to Floor Range	Tilt	Color
56.7 kg	1839 x 968 x 777 mm	200 x 100 - 600 x 400 mm	1130 - 1630 mm	±5°	S B



FUSION™ CART & STAND ACCESSORIES



FCA623*	Color	Compatibility
Dual Display Adapter Accessory	S B	XPAU, XVAU

*XPAU cart shown with FCA623 Dual display adapter.

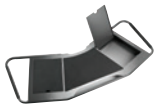

FCA612	Dimensions (WxD)	Weight Capacity	Compatibility
Large, Height-Adjustable Accessory Shelf	1219 x 529 mm	11.3 kg	MFAU, MPAU, LPAU, LFAU, XPAU

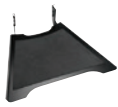

FCA611	Dimensions (WxD)	Weight Capacity	Compatibility
Small, Height-Adjustable Accessory Shelf	619 x 386 mm	11.3 kg	MFAU, MPAU, LPAU, LFAU



FCA650/651	Compatibility
Large & Medium CPU Holders	MFAU, MPAU, LPAU, LFAU
Model	Max Equipment Size (HxWxD)
FCA650	381 x 130 x 381 mm
FCA651	254 x 92 x 254 mm



FCA510/515	Compatibility
Storage Accessories	All Fusion Ceiling & Freestanding Mounts
Model	Dimensions (HxWxD)
FCA510	267 x 267 x 76 mm
FCA515	394 x 394 x 114 mm



FCA520	Max Equipment Depth	Compatibility
Universal Clamp Kit (Qty 2)	83 mm	All Fusion Ceiling & Freestanding Mounts



FCA500	Dimensions (WxD)	Weight Capacity	Compatibility
Component / Video Conference Shelf - Below	457 x 287 mm	9.1 kg	Fusion Landscape Ceiling & Freestanding Mounts



FCA501/502	Compatibility	
Component / Video Conference Shelves - Above	Fusion Landscape Ceiling & Freestanding Mounts	
Model	Dimensions (WxD)	Weight Capacity
FCA501	356 x 254 mm	4.5 kg
FCA502	203 x 254 mm	4.5 kg



FCA800/ FCA801+	Compatibility	
Above/Below Shelf, Large* Displays	Fusion Fixed & Tilt Wall, Freestanding & Ceiling Mounts	
Model	Size	Weight Capacity
FCA800	203 mm	9.1 kg
FCA801	355 mm	9.1 kg

*Typical screen size: 46-70".
 † Available spring, 2015.



FCA810/ FCA811+	Compatibility	
Above/Below Shelf, XL* Displays	Fusion Fixed & Tilt Wall, Freestanding & Ceiling Mounts	
Model	Size	Weight Capacity
FCA810	203 mm	9.1 kg
FCA811	355 mm	9.1 kg

* Typical screen size: 70-100".
 † Available spring, 2015.



FCA820/ FCA821+	Compatibility	
Fusion Center Camera Shelf	Fusion Ceiling, Freestanding and Wall Mounts	
Model	Size	Weight Capacity
FCA820	203 mm	9.1 kg
FCA821	355 mm	9.1 kg

† Available spring, 2015.

FUSION™ CART & STAND ACCESSORIES



FCA530	Weight Capacity	Compatibility
Center Channel Speaker Adapter	9.1 kg	Fusion Landscape Ceiling & Freestanding Mounts



FCA830/ FCA840+		Compatibility
Center Channel Speaker Adapter		Fusion Fixed & Tilt Wall, Freestanding & Ceiling Mounts
Model	Typical Screen Size	Weight Capacity
FCA830	52 - 80"	9.1 kg
FCA840	70 - 100"+	9.1 kg

* Available spring, 2015.



FCA535	Weight Capacity	Compatibility
Left/Right Speaker Adapters	4.5 kg per side	All Fusion Ceiling & Freestanding Mounts



FCA831/ FCA841+		Compatibility
Center Channel Speaker Adapter		Fusion Fixed & Tilt Wall, Freestanding & Ceiling Mounts
Model	Typical Screen Size	Weight Capacity
FCA831	42 - 70"	4.5 kg/side
FCA841	50 - 95"	4.5 kg/side

* Available spring, 2015.





FCACLIPS	Compatibility
Anchor Points for Zip Ties (Qty 10)	All Fusion Ceiling & Freestanding Mounts



AUTOMATED POP-UP LIFT FEATURES

 **CONTROL OPTIONS**
Multiple control options include serial communication, dry contact control and IR remote (included).

 **SMOOTH EXTENSION**
Fast and quiet travel at more than 51 mm per second with preset viewing positions.

 **CLICKCONNECT™**
Hear an audible click when the screen engages with the mount. Easy to connect/disconnect - no tools needed!

 **CABLE MANAGEMENT**
Unique cable management system allows cables to move freely with the lift.



CONTROL OPTIONS



SMOOTH EXTENSION

CM2L40UI 32 - 61" POP-UP LIFT



An automated floor lift with multiple control options including serial communication and IR remote.

Weight Capacity	Dimensions (HxWxD) (Retracted)	Mounting Patterns (W,H)	Max Extension	Overall Travel	Compatibility
86.2 kg	778 x 603 x 195 mm	200 x 200 - 862 x 517 mm	1083 mm	1016 mm	230VAC, 50Hz



OTHER CARTS & STANDS MOUNTS

PFCU 42 - 71" HEIGHT-ADJUSTABLE CART



A collapsible mobile cart for portrait and landscape orientations - ideal for corporate and rental/staging applications.

Weight Capacity	Dimensions (HxWxD)	Mounting Patterns (W,H)	Center of Display to Floor range	Tilt	Color
90.7 kg	2073 x 943 x 816 mm	200 x 200 - 862 x 517 mm	1220 x 1830 mm	±15°	B



PF1U 42 - 71" HEIGHT-ADJUSTABLE STAND



A solid, low profile single display floor stand with integrated cable management and support for both portrait and landscape orientations.

Weight Capacity	Dimensions (HxWxD)	Mounting Patterns (W,H)	Center of Display to Floor Range	Tilt	Color
90.7 kg	2388 x 914 x 762 mm	200 x 200 - 862 x 517 mm	1300 - 2170 mm	±15°	B



MFCU 30 - 55" HEIGHT-ADJUSTABLE CART



Smaller version of the PFC with landscape and portrait orientation capability.

Weight Capacity	Dimensions (HxWxD)	Mounting Patterns (W,H)	Center of Display to Floor Range	Tilt	Color
56.7 kg	1975 x 943 x 816 mm	100 x 100 - 709 x 431 mm	1220 - 1830 mm	±15°	B



MF1U 30 - 55" HEIGHT-ADJUSTABLE STAND



A solid, low profile single display floor stand with integrated cable management. Supports portrait and landscape orientations.

Weight Capacity	Dimensions (HxWxD)	Mounting Patterns (W,H)	Center of Display to Floor Range	Tilt	Color
56.7 kg	2327 x 914 x 762 mm	100 x 100 - 709 x 431 mm	1300 - 2180 mm	±15°	B



OTHER CARTS & STANDS ACCESSORIES



PAC722	Compatibility
P-Series Dual Side-by-Side Display Accessory	PFC, PF1



MAC722	Compatibility
M-Series Dual Side-by-Side Display Accessory	MFC, MF1



PAC715/716	Compatibility	
Video Conferencing Camera Shelves - Above or Below	P-Series (356 x 356 mm) & M-Series (200 x 200 mm) Q-Latch	
Model	Dimensions (WxD)	Weight Capacity
PAC715	229 x 223 mm	4.5 kg
PAC716	356 x 301 mm	4.5 kg



PAC710	Dimensions (WxD)	Weight Capacity	Compatibility
Height Adjustable Accessory Shelf	457 x 305 mm	11.3 kg	P- & M-Series Carts & Floor Stands



PAC730A	Max Equipment Size (HxWxD)	Compatibility
Secure Storage Shelf w/ Lock	89 x 445 x 305 mm	P- & M-Series Carts & Floor Stands

PACTP1	Compatibility
Touch Panel Stabilizer Kit	P- & M-Series Carts & Floor Stands



KFA220B/S	Compatibility
Dual Monitor Accessory - Black / Silver	P- & M-Series Carts & Floor Stands



KFA225B/S	Compatibility
Widescreen Dual Monitor Accessory - Black / Silver	P- & M-Series Carts & Floor Stands



KFA320B/S	Compatibility
Triple Monitor Accessory - Black / Silver	P- & M-Series Carts & Floor Stands



KFA325B/S	Compatibility
Widescreen Triple Monitor Accessory - Black / Silver	P- & M-Series Carts & Floor Stands

TABLE STAND DISPLAY MOUNTS

STLU 32 - 52" TABLE STAND



This bolt-down swivel table stand ships with security hardware - ideal for hospitality installs.

Weight Capacity	Dimensions (HxWxD)	Mounting Patterns (W,H)	Swivel Options
56.7 kg	603 x 698 x 140 mm	100 x 100 - 600 x 400 mm	15°, 30°, 45° or 90°



PTSU 30-50" TABLE STAND



Stylish solutions for residential, commercial and business applications.

Weight Capacity	Dimensions (HxWxD)	Mounting Patterns (W,H)	Height Adjust
45.4 kg	545 x 607 x 278 mm	200 x 200 - 860 x 515 mm	102 mm



STS1 18 - 30" BOLT-DOWN TABLE STAND



This secure, bolt-down table stand for small screens provides swivel and tilt capability - ideal for point of sale applications.

Weight Capacity	Dimensions (HxWxD)	Mounting Patterns (W,H)	Height Adjust	Pivot/Tilt	Swivel Range Options
13.6 kg	409 x 152 x 175 mm	75 x 75 - 100 x 100 mm	130 mm	±15°	90°, 180°, 270°





DESK MONITOR MOUNTS

(Shown with Apple® Cinema Display adapter, not included.)

KONTOUR™ K1 DYNAMIC HEIGHT-ADJUST DESK MOUNTS FEATURES



HEAVY DUTY DESIGN
Features sleek, solidly constructed forged aluminum arms.



ULTIMATE FLEXIBILITY
Gas-spring technology provides smooth dynamic height adjustment up to 330 mm and enables ideal positioning.



CABLE MANAGEMENT
Tool-free cable management covers create a clean, professional look.



FAST INSTALLATION
Simple 3-step installation and integrated quick-connect monitor interface makes mounting and maintenance easy.



CENTRIS® EXTREME TILT
Tilts -75°/+10° for the ultimate ergonomic solution.



MOUNTING PATTERN
Compatible with 75 x 75 mm and 100 x 100 mm VESA® patterns.

K1C220 DUAL MONITOR COLUMN CLAMP



This dynamic mount provides extended reach for 2 monitors. Offers independent manual height adjust on the column up to 178 mm and dynamic height adjust up to 330 mm. For reduced height: K1C220_XRH.

Minimum Depth from Back of Desk	Maximum Extension	Weight Capacity (per monitor)	Colors
62 mm	523 mm	2.3 - 9.9 kg	S B



K1C210 DUAL MONITOR COLUMN CLAMP



Provides a low-profile solution for 2 monitors installed next to a cubical wall or adjacent desk, with 178 mm independent manual height adjust and dynamic height adjust up to 330 mm. Features single-link arms.

Minimum Depth from Back of Desk	Maximum Extension	Weight Capacity (per monitor)	Colors
62 mm	352 mm	2.3 - 11.3 kg	S B



K1C22H DUAL MONITOR COLUMN CLAMP ARRAY



Securely holds 2 monitors on an array bar. Offers manual height adjust on the column up to 178 mm and dynamic height adjust up to 330 mm with dual-link arm. For reduced height: K1C22H_XRH.

Minimum Depth from Back of Desk	Maximum Extension	Weight Capacity (per monitor)	Max Display Width	Colors
156 mm	587 mm	0.9 - 4.08 kg	632 mm	S B



K1C120 SINGLE MONITOR COLUMN CLAMP



Dynamic dual-link mount provides extended reach for a single monitor. Offers manual height adjustment on the column up to 178 mm and dynamic height adjustment up to 330 mm. For reduced height: K1C120_XRH.

Minimum Depth from Back of Desk	Maximum Extension	Weight Capacity	Colors
62 mm	571 mm	2.3 - 9.9 kg	S B



K1C110 SINGLE MONITOR COLUMN CLAMP

Dynamic single-link mount provides extended reach for a single monitor. Offers manual height adjustment on the column up to 178 mm and dynamic height adjustment up to 330 mm.

Minimum Depth from Back of Desk	Maximum Extension	Weight Capacity	Colors
62 mm	400 mm	2.3 - 11.3 kg	S B

**K1D230** DUAL MONITOR DESK CLAMP

Featuring triple-link arms, this dynamic mount securely holds 2 monitors and provides 330 mm of dynamic height adjustment.

Minimum Depth from Back of Desk	Maximum Extension	Weight Capacity (per monitor)	Colors
62 mm	714 mm	2.3 - 4.54 kg	S B

**K1D220** DUAL MONITOR DESK CLAMP

Featuring dual-link arms, this dynamic mount securely holds 2 monitors and provides 330 mm of dynamic height adjustment. For reduced height: K1D220_XRH.

Minimum Depth from Back of Desk	Maximum Extension	Weight Capacity (per monitor)	Colors
62 mm	548 mm	2.3 - 11.3 kg	S B

**K1D22H** DUAL MONITOR DESK ARRAY

Securely holds 2 monitors on an array bar allowing for perfect alignment and low-profile placement. Flexible dual-link arm offers dynamic height adjustment up to 330 mm. For reduced height: K1D22H_XRH.

Minimum Depth from Back of Desk	Maximum Extension	Weight Capacity (per monitor)	Max Display Width	Colors
109 mm	538 mm	0.9 - 4.08 kg	632 mm	S B



K1D130 SINGLE MONITOR COLUMN CLAMP



Dynamic triple-link mount provides ultra-extended reach for a single monitor. Offers manual height adjustment on the column up to 178 mm and dynamic adjustment up to 330 mm.



Minimum Depth from Back of Desk	Maximum Extension	Weight Capacity (per monitor)	Colors
62 mm	648 mm	2.3 - 4.54 kg	S B

K1D120 SINGLE MONITOR DESK CLAMP



Dynamic dual-link mount securely holds a single monitor and provides up to 330 mm of dynamic height adjustment. For reduced height: K1D120_XRH.



Minimum Depth from Back of Desk	Maximum Extension	Weight Capacity	Colors
62 mm	523 mm	2.3 - 11.3 kg	S B

KONTOUR™ K1 DYNAMIC HEIGHT-ADJUST DESK MOUNTS ACCESSORIES



KRA219	Compatibility
Table Clamp Mount Kit	K1 and K2 Series Mounts*



KRA220	Compatibility
Extension Arm Accessory	K1 and K2 Series Mounts*



KRA221	Compatibility
K1C Expansion Arm	Compatibility: K1 Series Column Mounts



KRA223	Compatibility
Dual Monitor Array Bar	K1 and K2 Series Mounts*



KRA224	Compatibility
Dual Monitor Array Bar Handle	KRA223



KRA225	Compatibility
Extreme Tilt Head Accessory	K1 and K2 Series Mounts*



KSA1250B	Compatibility
Quick-Connect Interface for Dell UltraSharp Monitors	All Kontour products



KRA300	Compatibility
Laptop Accessory	K1 Series Mounts



FSBI2B	Compatibility
Portable iPad® Interface Bracket - iPad 2, and 3rd- & 4th-gen iPads	Kontour Series Mounts (requires KRA400B accessory with K1 Series)

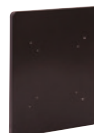

KRA400B	Compatibility
Weighted Adapter Plate	K1 Series Mounts + FSBI2B iPad interface



FSBI2TB	Compatibility
Secure iPad Interface Bracket - iPad 2 and 3rd-gen iPad	Kontour Series Mounts (requires KRA401B accessory with K1 Series)

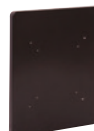

KRA401B	Compatibility
Weighted Adapter Plate	K1 Series Mounts + FSBI2TB iPad interface

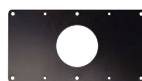

FSBV	Compatibility
Small Flat Panel Universal Interface Bracket	All Kontour Series Products

* Compatible with new K1 and K2 models only. Not compatible with discontinued models: K1C100, K1C200, K1C250, K1D100, K1D200, KS100, KS200, KIW100, KIW200, K1P100, K1P200, K2C100, K2C200, K2P100, K2P200, K2W100 and K2W200.

KONTOUR™ K2 DESK MOUNT FEATURES



HEAVY DUTY DESIGN
Features sleek, solidly constructed forged aluminum arms.



ULTIMATE FLEXIBILITY
Column mount slides vertically along column for ideal positioning and provides 273 mm of manual height adjustment.



FAST INSTALLATION
Tear-drop hole pattern for easy mounting and maintenance.



CABLE MANAGEMENT
Tool-free cable management guide clips for a clean, professional look.



CENTRIS® TILT
Tilts ±15° for a flexible, ergonomic solution.



MOUNTING PATTERN
Compatible with 75 x 75 mm and 100 x 100 mm VESA® patterns.

K2C220 DUAL MONITOR COLUMN CLAMP



Dual monitor column clamp mounts easily to edge of desk. Features flexible dual-link arms with independent manual height adjustment.



Minimum Depth from Back of Desk	Maximum Extension	Weight Capacity (per monitor)	Colors
105 mm	448 mm	9.9 kg	S B

K2C22H DUAL MONITOR COLUMN ARRAY



Securely holds 2 monitors on an array bar allowing for perfect alignment and low-profile placement. Flexible, dual-link arm offers manual height adjustment.



Minimum Depth from Back of Desk	Maximum Extension	Weight Capacity (per monitor)	Maximum Display Width	Colors
156 mm	499 mm	0.9 - 4.08 kg	632 mm	S B

K2C120 SINGLE MONITOR COLUMN CLAMP

Single monitor column clamp mounts easily to the edge of desk.
Features flexible dual-link arm with manual height adjustment.

Minimum Depth from Back of Desk	Maximum Extension	Weight Capacity	Colors
152 mm	495 mm	9.9 kg	S B

**K2C110** SINGLE MONITOR COLUMN CLAMP

Single monitor column clamp mounts easily to the edge of desk.
Features single-link arm with manual height adjustment.

Minimum Depth from Back of Desk	Maximum Extension	Weight Capacity	Colors
152 mm	324 mm	9.9 kg	S B



KONTOUR™ K2 SERIES DESK MOUNT ACCESSORIES



KRA219	Compatibility
Table Clamp Mount Kit	K1 and K2 Series Mounts*



KRA220	Compatibility
Extension Arm Accessory	K1 and K2 Series Mounts*



KRA221	Compatibility
K1C Expansion Arm	Compatibility: K1 Series Column Mounts



KRA223	Compatibility
Dual Monitor Array Bar	K1 and K2 Series Mounts*



KRA224	Compatibility
Dual Monitor Array Bar Handle	KRA223



KRA225	Compatibility
Extreme Tilt Head Accessory	K1 and K2 Series Mounts*



FSB4090B	Compatibility
Custom Interface Bracket for Cisco® EX90	K2 Series Mounts



KSA1250B	Compatibility
Quick-Connect Interface for Dell UltraSharp Monitors	All Kontour products



FSBI2B	Compatibility
Portable iPad® Interface Bracket - iPad 2, and 3rd- & 4th-gen iPads	Kontour Series Mounts (requires KRA400B accessory with K1 Series)



FSBI2TB	Compatibility
Secure iPad Interface Bracket - iPad 2 and 3rd-gen iPad	Kontour Series Mounts (requires KRA401B accessory with K1 Series)



FSBV	Compatibility
Small Flat Panel Universal Interface Bracket	All Kontour Series Products

* Compatible with new K1 and K2 models only. Not compatible with discontinued models: K1C100, K1C200, K1C250, K1D100, K1D200, KS100, K1S200, K1W100, K1W200, K1P100, K1P200, K2C100, K2C200, K2P100, K2P200, K2W100 and K2W200.



DESK ARRAY MONITOR MOUNTS

KONTOUR™ K3 STATIC DESK ARRAYS FEATURES



LATERAL SHIFT

Centris heads are easily moved along array arms for quick lateral shift adjustments.



ULTIMATE FLEXIBILITY

Independently height adjustable arms (and center head where applicable) provide seamless screen alignment. Arms can be adjusted from 0° to 15° for customized viewing angles.



HEAVY DUTY DESIGN

Features sleek, solidly constructed arms with that hold 6.8 kg per monitor.



CENTRIS™ TILT

Offers up to ±12° of Centris fingertip tilt for effortless display positioning.



MODULARITY

Meets a wide range of monitor sizes and configurations. A great multi-array solution for call centers, security desks, IT, health care, control rooms and other multi-monitor settings.



MOUNTING PATTERN

Compatible with 75 x 75 mm and 100 x 100 mm VESA® patterns.

K3F220B FREESTANDING 2x2 ARRAY



Static freestanding array mount for monitors 2 wide x 2 tall.

Maximum Monitor Height	Maximum Monitor Width	Tilt	Typical Screen Size	Weight Capacity (per monitor)	Colors
460 mm	736 mm	±12°	10 - 27"	6.8 kg	B



K3G220B GROMMET MOUNTED 2x2 ARRAY



Static grommet array mount for monitors 2 wide x 2 tall. Compatible with desks 13 - 127 mm thick.

Maximum Monitor Height	Max Monitor Width	Tilt	Typical Screen Size	Weight Capacity (per monitor)	Colors
460 mm	736 mm	±12°	10 - 27"	6.8 kg	B



K3G320B GROMMET MOUNTED 3x2 ARRAY



Static grommet array mounts for monitors 3 wide x 2 tall. Compatible with desks 13 - 127 mm thick.

Max Monitor Width	Tilt	Typical Screen Size	Weight Capacity (per monitor)	Colors
Dual display - 1301 mm Triple display - 650 mm	Outer - ±12° Center - ±10°	Dual: up to 30" Triple: up to 27"	6.8 kg	B

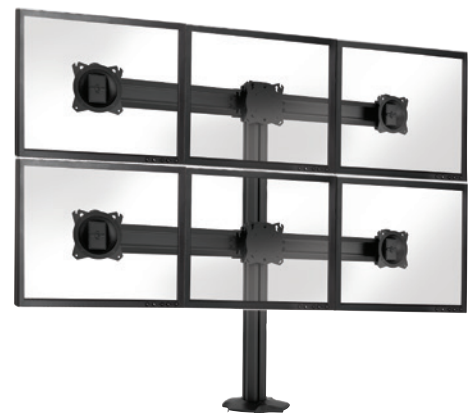

K3F310B FREESTANDING 3x1/2x1 ARRAY



Static freestanding array mount for 2 or 3 monitor/tablet combinations. Telescoping rails add 203 mm per arm of additional lateral adjustment.

Maximum Monitor Width	Tilt	Typical Screen Size	Weight Capacity (per monitor)	Colors
Dual display - 1301 mm Triple display - 650 mm	Outer - ±12° Center - ±10°	Dual: up to 30" Triple: up to 27"	6.8 kg	B



K3G310B GROMMET MOUNTED 3x1/2x1 ARRAY



Static grommet array mount for 2 - 3 monitor/tablet combinations. Telescoping rails add 203 mm per arm of additional lateral adjustment.

Monitor Width Range	Tilt	Typical Screen Size	Desktop Thickness	Weight Capacity (per monitor)	Colors
Dual display - 1301 mm Triple display - 650 mm	Outer - 12° Center - 10°	Dual: up to 30" Triple: up to 27"	13 - 127 mm	6.8 kg	B



K3F120B FREESTANDING 1x2 ARRAY



Static freestanding array mount for 2 monitors arranged vertically.

Maximum Monitor Height	Tilt	Typical Screen Size	Weight Capacity (per monitor)	Colors
460 mm	±10°	10 - 30"	6.8 kg	B

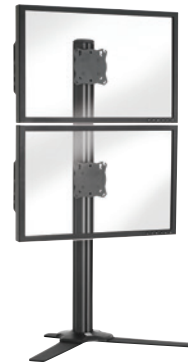

K3G120B GROMMET MOUNTED 1x2 ARRAY



Static grommet array mount for 2 monitors arranged vertically. Compatible with desks 13 - 127 mm thick.

Maximum Monitor Height	Tilt	Typical Screen Size	Weight Capacity (per monitor)	Colors
460 mm	±10°	10 - 30"	6.8 kg	B



KONTOUR™ K3 SERIES DESK ARRAY ACCESSORIES



KRA500	Compatibility
Desk Clamp Accessory	K3 Series Mounts



FSBI2TB	Compatibility
Secure iPad Interface Bracket - iPad 2 and 3rd-gen iPad	Kontour Series Mounts (requires KRA401B accessory with K1 Series)



KSA1250	Compatibility
Quick-Connect Interface for Dell UltraSharp Monitors	All Kontour products



FSBV	Compatibility
Small Flat Panel Universal Interface Bracket	All Kontour Series Products



FSBI2B	Compatibility
Portable iPad® Interface Bracket - iPad 2, and 3rd- & 4th-gen iPads	Kontour Series Mounts (requires KRA400B accessory with K1 Series)

KONTOUR™ K4 DEPTH-ADJUSTABLE DESK ARRAYS

FEATURES



FOCAL DEPTH ADJUSTMENT
Provides articulating focal depth adjustment for optimal ergonomics in multi-user environments, allowing you to reposition the bank of screens to a preferred viewing distance.



AESTHETIC DESIGN
Form meets function with the K4 Series. Solidly constructed, forged aluminum arms are sleekly designed for a clean appearance.



EXCEPTIONAL FLEXIBILITY
Swivel and pan adjustment capability and Centris® Fingertip Tilt for ideal screen positioning. Also includes an integrated handle for quick ergonomic adjustment to fit the user.



MOUNTING PATTERN
Compatible with 75 x 75 mm and 100 x 100 mm VESA® patterns.



CENTRIS® TILT
Offers up to ±12° of Centris™ fingertip tilt for effortless display positioning.

K4G610B GROMMET MOUNTED 6x1 ARRAY



Grommet array mount for 6 monitors in a row with two anchor points. Extends up to 412 mm and offers ±12° tilt and 20° rotation.

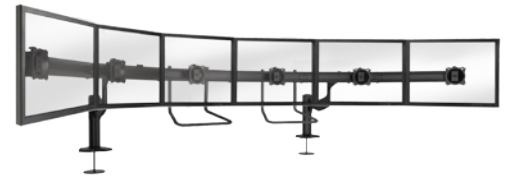

Center of Display to Table Range	Max Width (per monitor)	Minimum Depth	Typical Screen Size	Weight Cap. (per monitor)	Desktop Thickness
291 - 463 mm	614 mm	815 mm	up to 24"	6.8 kg	25 - 125 mm

K4G510B GROMMET MOUNTED 5x1 ARRAY



Grommet array mount for 5 monitors in a row with two anchor points. Extends up to 412 mm and offers ±12° tilt and 20° rotation.



Center of Display to Table Range	Max Width (per monitor)	Minimum Depth	Typical Screen Size	Weight Cap. (per monitor)	Desktop Thickness
291 - 463 mm	614 mm	592 mm	up to 24"	6.8 kg	25 - 125 mm

K4G410B GROMMET MOUNTED 4x1 ARRAY



Grommet array mount for 4 monitors in a row with two anchor points. Extends up to 412 mm and offers $\pm 12^\circ$ tilt and 20° rotation.



Center of Display to Table Range	Max Width (per monitor)	Minimum Depth	Typical Screen Size	Weight Cap. (per monitor)	Desktop Thickness
291 - 463 mm	614 mm	396 mm	up to 24"	6.8 kg	25 - 125 mm

K4G310B GROMMET MOUNTED 3x1 ARRAY



Grommet array mount for 3 monitors in a row with one anchor point. Extends up to 412 mm and offers $\pm 12^\circ$ tilt and 20° rotation.



Center of Display to Table Range	Max Width (per monitor)	Minimum Depth	Typical Screen Size	Weight Cap. (per monitor)	Desktop Thickness
291 - 463 mm	614 mm	239 mm	up to 24"	6.8 kg	25 - 125 mm

K4G210B GROMMET MOUNTED 2x1 ARRAY



Grommet array mount for 2 monitors in a row with one anchor point. Extends up to 412 mm and offers $\pm 12^\circ$ tilt and 20° rotation.



Center of Display to Table Range	Max Width (per monitor)	Minimum Depth	Typical Screen Size	Weight Cap. (per monitor)	Desktop Thickness
291 - 463 mm	943 mm	239 mm	up to 24"	6.8 kg	25 - 125 mm

K4G120B GROMMET MOUNTED 1x2 ARRAY



Grommet array mount for 2 monitors stacked with one anchor point. Offers $\pm 10^\circ$ tilt.



Center of Display to Table Range	Max. Monitor Height	Minimum Depth	Typical Screen Size	Weight Cap. (per monitor)	Desktop Thickness
291 - 463 mm	406 mm	239 mm	up to 24"	6.8 kg	25 - 125 mm

K4G620B GROMMET MOUNTED 6X2 ARRAY



Grommet array mount for 12 monitors stacked with two anchor points. Extends at least 305 mm and offers $\pm 12^\circ$ tilt.

Center of Display to Table Range	Max. Monitor Height	Minimum Depth	Typical Screen Size	Weight Cap. (per monitor)	Desktop Thickness
269 - 1107 mm	584 mm	815 mm	up to 24"	6.8 kg	25 - 125 mm

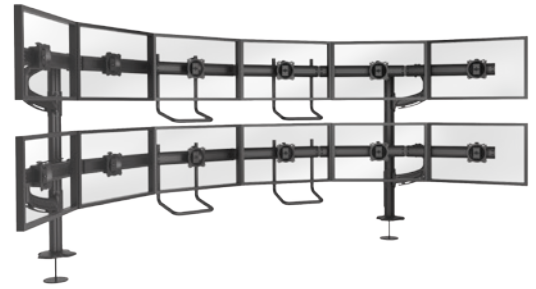

K4G520B GROMMET MOUNTED 5X2 ARRAY



Grommet array mount for 10 monitors in two rows with two anchor points. Extends at least 305 mm and offers $\pm 12^\circ$ tilt.

Center of Display to Table Range	Max Width (per monitor)	Minimum Depth	Typical Screen Size	Weight Cap. (per monitor)	Desktop Thickness
269 - 1107 mm	584 mm	592 mm	up to 24"	6.8 kg	25 - 125 mm

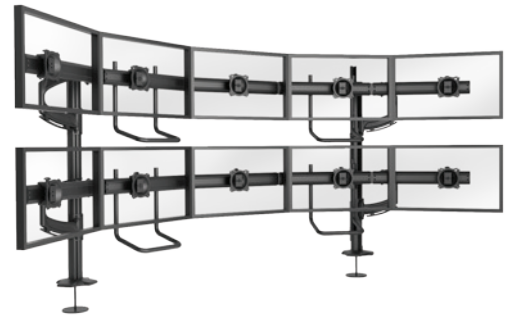

K4G420B GROMMET MOUNTED 4X2 ARRAY



Grommet array mount for 8 monitors in two rows with two anchor points. Extends at least 305 mm and offers $\pm 12^\circ$ tilt.

Center of Display to Table Range	Max Width (per monitor)	Minimum Depth	Typical Screen Size	Weight Cap. (per monitor)	Desktop Thickness
269 - 1107 mm	584 mm	396 mm	up to 24"	6.8 kg	25 - 125 mm

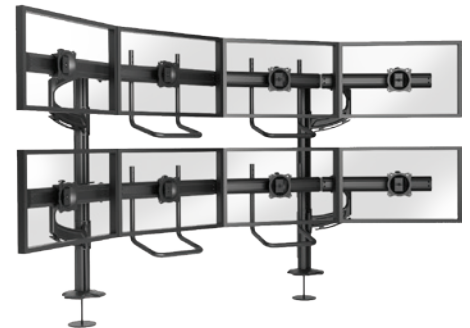

K4G320B GROMMET MOUNTED 3x2 ARRAY



Grommet array mount for 6 monitors in two rows with one anchor point. Extends at least 305 mm and offers $\pm 12^\circ$ tilt.

Center of Display to Table Range	Max Width (per monitor)	Minimum Depth	Typical Screen Size	Weight Cap. (per monitor)	Desktop Thickness
269 - 1107 mm	584 mm	318 mm	up to 24"	6.8 kg	25 - 125 mm



KONTOUR™ K4 SERIES DESK ARRAY ACCESSORIES



FSBI2B	Compatibility
Portable iPad® Interface Bracket - iPad 2, and 3rd- & 4th-gen iPads	Kontour Series Mounts (requires KRA400B accessory with K1 Series)



FSBI2TB	Compatibility
Secure iPad Interface Bracket - iPad 2 and 3rd-gen iPad	Kontour Series Mounts (requires KRA401B accessory with K1 Series)

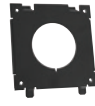

KSA1250	Compatibility
Quick-Connect Interface for Dell UltraSharp Monitors	All Kontour products



FSBV	Compatibility
Small Flat Panel Universal Interface Bracket	All Kontour Series Products



WALL MONITOR MOUNTS

KONTOUR™ K1 SERIES WALL MOUNT FEATURES



HEAVY DUTY DESIGN
Features sleek and solid forged aluminum arms.



ULTIMATE FLEXIBILITY
Gas-spring technology provides smooth dynamic height adjustment up to 330 mm and enables ideal monitor positioning.



FAST INSTALLATION
Simple 3-step installation and integrated quick-connect interface for easy mounting and maintenance.



CABLE MANAGEMENT
Tool-free cable management covers create a clean, professional look.



CENTRIS® EXTREME TILT
Tilts $-75^{\circ}/+10^{\circ}$ for an ultimate ergonomic solution.



MOUNTING PATTERN
Compatible with 75 x 75 mm and 100 x 100 mm VESA patterns.

K1W220 DUAL MONITOR WALL MOUNT



Featuring flexible dual-link arms, this dynamic mount securely attaches two monitors.

Minimum Depth from Wall	Maximum Extension	Weight Capacity (per monitor)	Colors
62 mm	525 mm	2.3 - 11.3 kg	S B



K1W22H DUAL MONITOR WALL ARRAY



Securely holds 2 monitors on an array bar allowing for perfect alignment and low-profile placement. Flexible dual-link arm. Offers ±10° of tilt.

Minimum Depth from Wall	Maximum Extension	Weight Capacity (per monitor)	Maximum Display Width	Colors
79 mm	528 mm	0.9 - 4.08 kg	632 mm	S B



K1W120 SINGLE MONITOR WALL MOUNT



Dynamic mount securely attaches a single monitor. Features flexible dual-link arm.

Minimum Depth from Wall	Maximum Extension	Weight Capacity	Colors
62 mm	512 mm	2.3 - 11.3 kg	S B



K1W110 SINGLE MONITOR WALL MOUNT









Dynamic mount with single-link arm securely attaches single monitor.

Minimum Depth from Wall	Maximum Extension	Weight Capacity	Colors
62 mm	341 mm	2.3 - 11.3 kg	S B



KONTOUR K1 SERIES WALL MOUNT ACCESSORIES

	<table border="1"> <tr> <th>KRA300</th> <th>Compatibility</th> </tr> <tr> <td>Laptop Accessory</td> <td>K1 Series Mounts</td> </tr> </table>	KRA300	Compatibility	Laptop Accessory	K1 Series Mounts
KRA300	Compatibility				
Laptop Accessory	K1 Series Mounts				
	<table border="1"> <tr> <th>KSA1250B</th> <th>Compatibility</th> </tr> <tr> <td>Quick-Connect Interface for Dell UltraSharp Monitors</td> <td>All Kontour products</td> </tr> </table>	KSA1250B	Compatibility	Quick-Connect Interface for Dell UltraSharp Monitors	All Kontour products
KSA1250B	Compatibility				
Quick-Connect Interface for Dell UltraSharp Monitors	All Kontour products				
	<table border="1"> <tr> <th>KRA219</th> <th>Compatibility</th> </tr> <tr> <td>Table Clamp Mount Kit</td> <td>K1 and K2 Series Mounts*</td> </tr> </table>	KRA219	Compatibility	Table Clamp Mount Kit	K1 and K2 Series Mounts*
KRA219	Compatibility				
Table Clamp Mount Kit	K1 and K2 Series Mounts*				
	<table border="1"> <tr> <th>KRA220</th> <th>Compatibility</th> </tr> <tr> <td>Extension Arm Accessory</td> <td>K1 and K2 Series Mounts*</td> </tr> </table>	KRA220	Compatibility	Extension Arm Accessory	K1 and K2 Series Mounts*
KRA220	Compatibility				
Extension Arm Accessory	K1 and K2 Series Mounts*				
	<table border="1"> <tr> <th>KRA223</th> <th>Compatibility</th> </tr> <tr> <td>Dual Monitor Array Bar</td> <td>K1 and K2 Series Mounts*</td> </tr> </table>	KRA223	Compatibility	Dual Monitor Array Bar	K1 and K2 Series Mounts*
KRA223	Compatibility				
Dual Monitor Array Bar	K1 and K2 Series Mounts*				
	<table border="1"> <tr> <th>KRA224</th> <th>Compatibility</th> </tr> <tr> <td>Dual Monitor Array Bar Handle</td> <td>K1 and K2 Series Mounts*</td> </tr> </table>	KRA224	Compatibility	Dual Monitor Array Bar Handle	K1 and K2 Series Mounts*
KRA224	Compatibility				
Dual Monitor Array Bar Handle	K1 and K2 Series Mounts*				

	<table border="1"> <tr> <th>FSBI2B</th> <th>Compatibility</th> </tr> <tr> <td>Portable iPad® Interface Bracket - iPad 2, and 3rd- & 4th-gen iPads</td> <td>Kontour Series Mounts (requires KRA400B accessory with K1)</td> </tr> </table>	FSBI2B	Compatibility	Portable iPad® Interface Bracket - iPad 2, and 3rd- & 4th-gen iPads	Kontour Series Mounts (requires KRA400B accessory with K1)
FSBI2B	Compatibility				
Portable iPad® Interface Bracket - iPad 2, and 3rd- & 4th-gen iPads	Kontour Series Mounts (requires KRA400B accessory with K1)				
	<table border="1"> <tr> <th>KRA400B</th> <th>Compatibility</th> </tr> <tr> <td>Weighted Adapter Plate</td> <td>K1 Series Mounts + FSBI2B iPad interface</td> </tr> </table>	KRA400B	Compatibility	Weighted Adapter Plate	K1 Series Mounts + FSBI2B iPad interface
KRA400B	Compatibility				
Weighted Adapter Plate	K1 Series Mounts + FSBI2B iPad interface				
	<table border="1"> <tr> <th>FSBI2TB</th> <th>Compatibility</th> </tr> <tr> <td>Secure iPad Interface Bracket - iPad 2 and 3rd-gen iPad</td> <td>Kontour Series Mounts (requires KRA400B accessory with K1)</td> </tr> </table>	FSBI2TB	Compatibility	Secure iPad Interface Bracket - iPad 2 and 3rd-gen iPad	Kontour Series Mounts (requires KRA400B accessory with K1)
FSBI2TB	Compatibility				
Secure iPad Interface Bracket - iPad 2 and 3rd-gen iPad	Kontour Series Mounts (requires KRA400B accessory with K1)				
	<table border="1"> <tr> <th>KRA401B</th> <th>Compatibility</th> </tr> <tr> <td>Weighted Adapter Plate</td> <td>K1 Series Mounts + FSBI2TB iPad interface</td> </tr> </table>	KRA401B	Compatibility	Weighted Adapter Plate	K1 Series Mounts + FSBI2TB iPad interface
KRA401B	Compatibility				
Weighted Adapter Plate	K1 Series Mounts + FSBI2TB iPad interface				
	<table border="1"> <tr> <th>FSBV</th> <th>Compatibility</th> </tr> <tr> <td>Small Flat Panel Universal Interface Bracket</td> <td>All Kontour Series Products</td> </tr> </table>	FSBV	Compatibility	Small Flat Panel Universal Interface Bracket	All Kontour Series Products
FSBV	Compatibility				
Small Flat Panel Universal Interface Bracket	All Kontour Series Products				

* Compatible with new K1 and K2 models only. Not compatible with discontinued models: K1C100, K1C200, K1C250, K1D100, K1D200, KS100, K1S200, K1W100, K1W200, K1P100, K1P200, K2C100, K2C200, K2P100, K2P200, K2W100 and K2W200.

KONTOUR™ K2 SERIES WALL MOUNT FEATURES



HEAVY DUTY DESIGN
Features sleek, solidly constructed forged aluminum arms.



FAST INSTALLATION
Tear-drop hole pattern for easy mounting and maintenance.



CENTRIS™ TILT
Tilts ±15° for a flexible ergonomic solution.



CABLE MANAGEMENT
Tool-free cable management guide clips for a clean, professional look.



MOUNTING PATTERN
Compatible with 75 x 75 mm and 100 x 100 mm VESA® patterns.



CENTRIS™ TILT

K2W220 DUAL MONITOR WALL MOUNT



Securely attaches 2 monitors to wall. Features dual-link arms for added flexibility.

Minimum Depth from Back of Wall	Maximum Extension	Weight Capacity (per monitor)	Colors
75 mm	450 mm	11.3 kg	S B



K2W22H DUAL MONITOR WALL ARRAY



Securely holds 2 monitors on an array bar allowing for perfect alignment and low-profile placement.

Minimum Depth from Back of Wall	Maximum Extension	Weight Capacity (per monitor)	Maximum Display Width	Colors
79 mm	441 mm	0.9 - 4.08 kg	632 mm	S B



K2W120 SINGLE MONITOR WALL MOUNT

Securely attaches a single monitor to the wall. Features a dual-link arm for added flexibility.

Minimum Depth from Back of Wall	Maximum Extension	Weight Capacity	Colors
75 mm	437 mm	18.14 kg	S B

**K2W110** SINGLE MONITOR WALL MOUNT

Securely attaches a monitor to the wall with a single-link arm.

Minimum Depth from Back of Wall	Maximum Extension	Weight Capacity	Colors
75 mm	265 mm	18.14 kg	S B



KONTOUR™ K2 SERIES WALL MOUNT ACCESSORIES



OFB-xxx	Compatibility
Office Furniture Interface Brackets	K1 and K2 Series Wall Mounts



OFBU	Compatibility	Colors
Universal Heavy-Duty Slat Wall Interface Bracket	K1 and K2 Series Wall Mounts	S B



OFBLU	Compatibility	Colors
Universal Low profile Slat Wall Interface Bracket	KOW100, K1W110 and K1W120	S B



KSA1250B	Compatibility
Quick-Connect Interface for Dell UltraSharp Monitors	All Kontour products



FSBI2B	Compatibility
Portable iPad® Interface Bracket - iPad 2, and 3rd- & 4th-gen iPads	Kontour Series Mounts (requires KRA400B accessory with K1)



FSBI2TB	Compatibility
Secure iPad Interface Bracket - iPad 2 and 3rd-gen iPad	Kontour Series Mounts (requires KRA401B accessory with K1)



FSBV	Compatibility
Small Flat Panel Universal Interface Bracket	All Kontour Series Products

OTHER KONTOUR™ WALL MOUNTS

KOW100 PITCH/PIVOT SINGLE WALL MOUNT

Easily attaches a monitor to the wall and provides smooth pivot and tilt adjustment for optimal viewing.

Weight Capacity	Mounting Patterns (W,H)	Tilt	Minimum Depth from Wall	Typical Screen Size	Colors
11.3 kg	75 x 75 mm, 100 x 100 mm	+75°, -10°	81 mm	10 - 30"	S B



KONTOUR™ K4 SERIES WALL MOUNT FEATURES



MODULARITY

An easily adjustable solution for monitor array workstations where multiple users need to reposition the bank of screens to their preferred viewing distance. Perfect for control rooms, trading desks, call centers, security desks, IT, healthcare and more.



AESTHETIC DESIGN

Form meets function with the K4 Series. Solidly constructed, forged aluminum arms are sleekly designed for a clean appearance.



EXCEPTIONAL FLEXIBILITY

Provides articulating focal depth adjustment, swivel and pan adjustment capability and Centris® Fingertip Tilt for ideal screen positioning. Also includes an integrated handle for quick ergonomic adjustment to fit the user.



MOUNTING PATTERN

Compatible with 75 x 75 mm and 100 x 100 mm VESA® patterns.

K4W310B WALL MOUNTED 3x1 ARRAY



Adjustable wall mount for 3 monitors in a row with one anchor point.



Max. Monitor Width	Extension	Minimum Depth	Arm Rotation	Typical Screen Size	Tilt	Weight Capacity (per monitor)
614 mm	412 mm	239 mm	0 - 20°	up to 24"	±12°	6.8 kg

K4W210B WALL MOUNTED 2x1 ARRAY



Adjustable wall mount for 2 monitors in a row with one anchor point.



Max. Monitor Width	Extension	Minimum Depth	Arm Rotation	Typical Screen Size	Tilt	Weight Capacity (per monitor)
943 mm	412 mm	239 mm	0 - 20°	up to 30"	±12°	6.8 kg

K4W120B WALL MOUNTED 1x2 ARRAY

Adjustable wall mount for 2 monitors arranged vertically with one anchor point.

Max. Monitor Height	Extension	Minimum Depth	Tilt	Weight Capacity (per monitor)
406 mm	412 mm	94 mm	±10°	6.8 kg

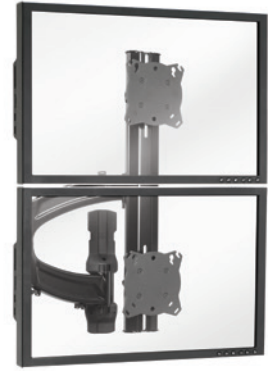

KONTOUR™ K1 SERIES POLE MOUNT FEATURES



EASY INSTALLATION
Simple 3-step installation and integrated quick-connect interface makes mounting and maintenance easy. Mounts on pre-existing poles with 38 - 48 mm outer diameters.



CENTRIS® EXTREME TILT
Centris® technology provides effortless tilt up to -75/+10°.



MOUNTING PATTERN
Compatible with 75 x 75 mm and 100 x 100 mm VESA® patterns.



HEAVY DUTY DESIGN
Features sleek and solid forged aluminum arms.



ULTIMATE FLEXIBILITY
Gas-spring technology provides smooth dynamic height adjustment up to 330 mm and enables ideal monitor positioning.



CABLE MANAGEMENT
Tool-free cable management covers create a clean, professional look.

K1P220 DUAL MONITOR POLE MOUNT



Dynamic pole mount firmly holds 2 monitors. Flexible dual-link arms provide up to 330 mm of height adjustment.

Minimum Depth from Pole	Extension	Weight Capacity (per monitor)	Colors
62 mm	510 mm	2.3 - 11.3 kg	S B



K1P22H DUAL MONITOR POLE ARRAY



Securely holds 2 monitors on an array bar allowing for perfect alignment and low-profile placement. Flexible dual-link arm provides up to 330 mm of height adjustment.

Minimum Depth from Pole	Maximum Extension	Weight Capacity (per monitor)	Maximum Display Width	Colors
79 mm	523 mm	0.9 - 4.08 kg	632 mm	S B



K1P120 SINGLE MONITOR POLE MOUNT



Flexible dual-link arm provides up to 330 mm of height adjustment.



Minimum Depth from Pole	Extension	Weight Capacity	Colors
64 mm	493 mm	2.3 - 11.3 kg	S B

K1P110 SINGLE MONITOR POLE MOUNT



Dynamic pole mount firmly holds a single monitor. Single-link arm provides up to 13" (330 mm) of height adjustment.



Minimum Depth from Pole	Maximum Extension	Weight Capacity	Colors
64 mm	322 mm	2.3 - 11.3 kg	S B

KONTOUR™ K1 SERIES POLE MOUNT ACCESSORIES



KRA300	Compatibility
Laptop Accessory	K1 Series Mounts



KSA1250B	Compatibility
Quick-Connect Interface for Dell UltraSharp Monitors	All Kontour products



FSBI2B	Compatibility
Portable iPad® Interface Bracket - iPad 2, and 3rd- & 4th-gen iPads	Kontour Series Mounts (requires KRA400B accessory with K1 Series)



KRA400B	Compatibility
Weighted Adapter Plate	K1 Series Mounts + FSBI2B iPad interface



FSBI2TB	Compatibility
Secure iPad Interface Bracket - iPad 2 and 3rd-gen iPad	Kontour Series Mounts (requires KRA401B accessory with K1 Series)



KRA401B	Compatibility
Weighted Adapter Plate	K1 Series Mounts + FSBI2TB iPad interface



FSBV	Compatibility
Small Flat Panel Universal Interface Bracket	All Kontour Series Products

KONTOUR™ K2 SERIES POLE MOUNT FEATURES



HEAVY DUTY DESIGN
Features sleek, solidly constructed forged aluminum arms.



CENTRIS™ TILT
Centris® technology provides effortless tilt up to ±15°.



CABLE MANAGEMENT
Includes tool-free cable management loops for a clean, professional look.



EASY INSTALLATION
Teardrop hole pattern makes mounting the screens quick and easy. Mounts on pre-existing poles with 38 - 48 mm outer diameters.



MOUNTING PATTERN
Compatible with 75 x 75 mm and 100 x 100 mm VESA® patterns.

K2P220 DUAL MONITOR POLE MOUNT



Pole mount firmly holds 2 monitors. Dual-link arm offers added flexibility.



Minimum Depth from Pole	Maximum Extension	Weight Capacity (per monitor)	Colors
74 mm	434 mm	11.3 kg	S B

K2P22H DUAL MONITOR POLE ARRAY



Securely holds 2 monitors on an array bar allowing for perfect alignment and low-profile placement. Dual-link arm offers added flexibility.



Minimum Depth from Pole	Maximum Extension	Weight Capacity (per monitor)	Maximum Display Width	Colors
79 mm	424 mm	0.9 - 4.08 kg	632 mm	S B

K2P120 SINGLE MONITOR POLE MOUNT

Pole mount firmly holds a single monitor. Dual-link arm offers added flexibility.

Minimum Depth from Pole	Maximum Extension	Weight Capacity	Colors
74 mm	422 mm	18.14 kg	S B

**K2P110** SINGLE DISPLAY POLE MOUNT

Pole mount with single-link arm firmly holds a single monitor.

Minimum Depth from Pole	Maximum Extension	Weight Capacity	Colors
74 mm	250 mm	18.14 kg	S B



KONTOUR™ K2 SERIES POLE MOUNT ACCESSORIES



FSBI2B	Compatibility
Portable iPad® Interface Bracket - iPad 2, and 3rd- & 4th-gen iPads	K1 Series Mounts (requires KRA400B accessory with K1 Series)



FSBI2TB	Compatibility
Secure iPad Interface Bracket - iPad 2 and 3rd-gen iPad	K1 Series Mounts (requires KRA401B accessory with K1 Series)



KSA1250B	Compatibility
Quick-Connect Interface for Dell UltraSharp Monitors	All Kontour products



FSBV	Compatibility
Small Flat Panel Universal Interface Bracket	All Kontour Series Products

OTHER KONTOUR™ POLE MOUNT

KOP100 SINGLE MONITOR POLE MOUNT



Easily attaches a monitor to a pole and provides smooth pivot and tilt adjustment.

Column Diameter Range	Weight Capacity	Mounting Patterns (W,H)	Tilt	Min.Depth from Pole	Typical Screen Size	Colors
38 - 48 mm	18.14 kg	75 x 75 mm, 100 x 100 mm	+75°, -10°	66 mm	10 - 30"	S B





TABLET MOUNTS

ALL-IN-ONE TABLET MOUNT FEATURES



COMPLETE SOLUTION

Simplify ordering and installation with these preconfigured solutions. Each kit includes a Kontour™ mount and tablet interface bracket.



STABLE POSITIONING

Your tablet stays where you place it, creating a productive, ergonomic workspace or display.



SLEEK DESIGN

Features custom molded materials, minimalist design and durable functionality.

KOW100BXi2B PITCH/PIVOT FLUSH - PORTABLE



Allows for pan, tilt and portrait/landscape rotation of an iPad® 2, 3rd- or 4th-gen iPad. FSBi2B interface offers easy iPad® removal.

Dimensions (HxWxD)	Tilt	Weight Capacity
286 x 217 x 105 mm	+40° / -10°	0.9 kg



KOW100BXi2TB PITCH/PIVOT FLUSH - SECURE



Allows for pan, tilt and portrait/landscape rotation of an iPad® 2 or 3rd-gen iPad with 30-pin connector. FSBi2TB interface deters theft.

Dimensions (HxWxD)	Tilt	Weight Capacity
286 x 217 x 105 mm	+40° / -10°	0.9 kg



FSRi2T iPad FLUSH MOUNT



Great for boardroom or home control applications. Holds iPad® 2 or 3rd-gen iPad with 30-pin connector and includes security hardware for theft deterrence.

Dimensions	Weight Capacity	Colors
290 x 206 mm	0.9 kg	S B



K1D220BXi2B DESK CLAMP - PORTABLE INTERFACE



Dynamic clamp mount with FSBi2B portable interface for an iPad® 2, 3rd- or 4th-gen iPad. Includes KRA400B weight plate adapter.

Maximum Extension	Minimum Depth	Tilt	Desktop Thickness	Weight Capacity (per monitor)
506 mm	62 mm	+75°, -10°	13 - 64 mm	2.3 - 11.3 kg



K1C120BXi2B COLUMN CLAMP - PORTABLE INTERFACE



Column mount with FSBi2B portable interface for an iPad® 2, 3rd- or 4th-gen iPad. Includes KRA400B weight plate adapter.

Dynamic Height Adjust	Manual Height Adjustment	Minimum Depth	Tilt	Weight Capacity
330 mm	273 mm	54 mm	+75°, -10°	2.3 - 9.9 kg



ONLINE TOOLS

RACKBUILDER™

RackBuilder™ is Chief’s intuitive web application for visually configuring rack solutions with an extensive library of accessories and third party component data. RackBuilder includes user-friendly capabilities such as photo realistic images, line views and side views of the rack design. Users can get a rack layout, parts list, and pricing very quickly. Sharing current rack projects with others for feedback and changes further enhances the online tool’s usefulness. rackbuilder.chiefmfg.com



RACKBUILDER 2.0 FEATURES

CHIEF INTRODUCES THE NEXT EVOLUTION OF RACKBUILDER™ After gathering customer feedback, Chief has implemented new user-friendly features that make the application - RackBuilder 2.0 - easier to use and more powerful than ever. Upgrades include:

- Smart logic and real-time notification about accessory compatibilities
- An upgraded, streamlined interface
- A 3rd party components compatibility database
- Drag-and-drop editing
- The ability to save a library of configurations
- Access to MSRP pricing
- A SpecBuilder™ automated collection option that gathers all necessary DWG, CAD and related documents



S1 SERIES KNOCK DOWN RACKS

NS1F Series 23" OR 28" DEPTHS

Rack rails can be field cut to length to shorten the rack if required by unexpected changes to the installation space. Includes floor levelers, 3U blanking/alignment panels, bottom vent panel and top 3U blanking panels. Casters, doors and side panels ordered separately.

RAXXESS™ S1 SERIES FEATURES

RACKBUILDER™

Customize this rack in RackBuilder to your exact specifications. Details on page 119.

KNOCK DOWN

The easiest-to-assemble knock down rack on the market.

INSTALLER-FRIENDLY

The rails are self-supported during assembly allowing one person to easily construct the rack in less than five minutes.

EASY-TO-ADD ACCESSORIES

Steel flanged blanking panels at the top are easily removed to accept any two 3U fans or panels.

CABLE MANAGEMENT

The side braces are punched to accept additional rack rails or can be used as a place to land cable ties. Conduit knockouts are laser cut in top and bottom of rack.



S1 SERIES RACKS

Model	Rack Height	Overall Depth	Usable Depth	Width	Height	Height with Casters
NS1F1223	12 space	584 mm	574 mm	489 mm	724 mm	762 mm
NS1F2023	20 space	584 mm	574 mm		1079 mm	1110 mm
NS1F2823	28 space	584 mm	574 mm		1435 mm	1473 mm
NS1F3628	36 space	711 mm	701 mm		1790 mm	1828 mm
NS1F4128	41 space	711 mm	701 mm		2010 mm	2057 mm

S1 SERIES ACCESSORIES



S1 Steel Rack Door Options		
Model	Rack Height	Type
NSID12S	12 space	Solid Steel
NSID20S	20 space	Solid Steel
NSID28S	28 space	Solid Steel
NSID36S	36 space	Solid Steel
NSID41S	41 space	Solid Steel



S1 Perforated Rack Door Options		
Model	Rack Height	Type
NSID12F	12 space	Perforated Steel
NSID20F	20 space	Perforated Steel
NSID28F	28 space	Perforated Steel
NSID36F	36 space	Perforated Steel
NSID41F	41 space	Perforated Steel



S1 Plexi Rack Door Options		
Model	Rack Height	Type
NSID12P	12 space	Plexi
NSID20P	20 space	Plexi
NSID28P	28 space	Plexi
NSID36P	36 space	Plexi
NSID41P	41 space	Plexi



S1 Rack Side Panel Pair Options		
Model	Rack Height	Rack Depth
NSIS1223	12 space	584 mm
NSIS2023	20 space	584 mm
NSIS2823	28 space	584 mm
NSIS3628	36 space	711 mm
NSIS4128	41 space	711 mm

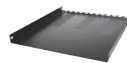

S1 Zero Height Rack Shelf Options		
Model	Rack Height	Rack Depth
NASIS23	0 space	584 mm
NASIS28	0 space	711 mm

More universal rack accessories available on page 133.

G1 SERIES GANGABLE RACKS

NG1F Series 33" DEPTH

Rear rack rail is included for easy cable management. Floor levelers, casters, front and rear doors and side panels ordered separately.

RAXXESS™ G1 SERIES FEATURES

RACKBUILDER™

Customize this rack in RackBuilder to your exact specifications. Details on page 119.

HASSLE-FREE

Pre-welded ganging nuts and included hardware provide the ability to gang racks after components are loaded.

SMART PACKAGING

Packaged with padding that stays on the rear of the rack after other packaging is removed so the rack can be safely laid on the floor to load heavy components.

EASY-TO-ADD ACCESSORIES

Steel flanged blanking panels at the top are easily removed to accept any two 3U fans or panels.



G1 SERIES RACKS

Model	Rack Height	Overall Depth	Usable Depth	Width	Height	Height with Casters
NG1F2833	28 space	838 mm	749 mm	522 mm	1422 mm	1458 mm
NG1F3633	36 space				1778 mm	1814 mm
NG1F4433	44 space				2134 mm	2169 mm

G1 SERIES ACCESSORIES



G1 Steel Rack Door (front or rear) Options		
Model	Rack Height	Type
NG1D28S	28 space	Solid Steel
NG1D36S	36 space	Solid Steel
NG1D44S	44 space	Solid Steel



G1 Plexi Rack Door (front or rear) Options		
Model	Rack Height	Type
NG1D28P	28 space	Plexi
NG1D36P	36 space	Plexi
NG1D44P	44 space	Plexi



G1 Perforated Steel Rack Door (front or rear) Options		
Model	Rack Height	Type
NG1D28F	28 space	Perforated Steel
NG1D36F	36 space	Perforated Steel
NG1D44F	44 space	Perforated Steel



G1 Steel Rack Side Panel Pair Options		
Model	Rack Height	Rack Depth
NG1S2833	28 space	838 mm
NG1S3633	36 space	838 mm
NG1S4433	44 space	838 mm

More universal rack accessories available on page 133.

E1 SERIES ENCLOSED RACKS

✓ **NE1F Series** 23" OR 28" DEPTHS

Covered vented bottom panel provides additional space for mounting components, for cable entry or a filtered fan intake panel for cooling components. Shown with optional floor levelers and casters installed. Floor levelers, casters and doors ordered separately.

RAXXESS™ E1 SERIES FEATURES

RACKBUILDER™

Customize this rack in RackBuilder to your exact specifications. Details on page 119.

CUSTOMIZABLE

Adjustable depth front and rear rack rails along with seal-able vent openings to quickly create the rack you need.

SMART PACKAGING

Packaged with padding that stays on the rear of the rack after other packaging is removed so the rack can be safely laid on the floor to load heavy components.

EASY-TO-ADD ACCESSORIES

Steel flanged blanking panels at the top are easily removed to accept any two 3U fans or panels.



E1 SERIES RACKS

Model	Rack Height	Overall Depth	Usable Depth	Width	Height	Height with Casters
NE1F2023	20 space	584 mm	514 mm	597 mm	1066 mm	1100 mm
NE1F2823	28 space	584 mm	514 mm		1419 mm	1457 mm
NE1F3628	36 space	711 mm	641 mm		1775 mm	1811 mm
NE1F4428	44 space	711 mm	641 mm		2130 mm	2166 mm

E1 SERIES ACCESSORIES



E1 Steel Rack Door (front or rear) Options		
Model	Rack Height	Type
NE1D20S	20 space	Solid Steel
NE1D28S	28 space	Solid Steel
NE1D36S	36 space	Solid Steel
NE1D44S	44 space	Solid Steel



E1 Plexi Rack Door (front or rear) Options		
Model	Rack Height	Type
NE1D20P	20 space	Plexi
NE1D28P	28 space	Plexi
NE1D36P	36 space	Plexi
NE1D44P	44 space	Plexi



E1 Perforated Steel Rack Door (front or rear) Options		
Model	Rack Height	Type
NE1D20F	20 space	Perforated Steel
NE1D28F	28 space	Perforated Steel
NE1D36F	36 space	Perforated Steel
NE1D44F	44 space	Perforated Steel

More universal rack accessories available on page 133.

RAXXESS™ F1 SERIES

FEATURES

RACKBUILDER™

Customize this rack in RackBuilder to your exact specifications. Details on page 119.

FULLY ASSEMBLED RACK

Ships with large 101 mm lockable casters that can be installed for easy maneuverability. Reversible swing front and rear doors add flexibility.

SLEEK AESTHETICS

Great solution for boardrooms and video conferencing with several available finishes (Black and Maple).

THERMAL MANAGEMENT

Two steel flanged blanking panels in the rear door are easily removed to accept any 3U fans or panels.

YF1F Series 30" DEPTH

Steel frame core for strength, stability and to prevent caster tear-outs.

Model	Rack Height	Overall Depth	Usable Depth	Width	Height	Height with Casters	Finish
YF1F1228B	12 space	762 mm	642 mm	677 mm	754 mm	863 mm	Ⓟ
YF1F1228M							Ⓜ
YF1F2028B	20 space				1110 mm	1219 mm	Ⓟ



F1 SERIES

ACCESSORY



YAMF1
F1 Rack Monitor Mount Arm

ROTATING & PULL-OUT RACKS

RAXXESS™ ROTATING & PULL-OUT RACK FEATURES

RACKBUILDER™

Customize this rack in RackBuilder to your exact specifications. Details on page 119.

HEAVY DUTY DESIGN

Rated to carry up to 136 kg of equipment. HD models allow for greater weight capacity.

ACCESSIBLE

Pull out racks provide easy access to equipment and wiring when space is at a premium.

CABLE MANAGEMENT

Included cable management system keeps wiring organized when the rack is pulled out for service.

SAFETY

Bottom cover panel keeps the rack from being pulled out accidentally.

POTR & POTR-XL PULL-OUT RACK

In-wall pull out rack. Required installation depth of 479 mm for POTR and 580 mm for POTR-XL. Assembly required.

Model	Rack Height	Height	Overall Depth	Usable Depth	Width	Extension
POTR-12	12 space	598 mm	480 mm	467 mm	489 mm	475 mm
POTR-XL-12			582 mm	533 mm		551 mm
POTR-24	24 space	1132 mm	480 mm	467 mm		475 mm
POTR-XL-24			582 mm	533 mm		551 mm



ROTR PULL-OUT ROTATING RACK WITH 480 MM DEPTH

In-wall pull out rotating rack. Designed for flush cabinet door installations. Assembly required.

Model	Rack Height	Height	Overall Depth	Usable Depth	Width
ROTR-12	12 space	622 mm	480 mm	467 mm	489 mm
ROTR-24	24 space	1156 mm			



ROTR-XL PULL-OUT ROTATING RACK WITH 582 MM DEPTH

In-wall pull out rotating rack. Designed for recessed cabinet door installations. Assembly required.

Model	Rack Height	Height	Overall Depth	Usable Depth	Width
ROTR-XL-12	12 space	622 mm	582 mm	467 mm	489 mm
ROTR-XL-24	24 space	1156 mm			



ROTR-HD 24U+ PULL-OUT ROTATING RACK WITH 597 MM DEPTH

In-wall pull out rack. Designed for heavy duty rack installations. Assembly required.

Model	Rack Height	Height	Overall Depth	Usable Depth	Width	Min Sill Height*
ROTR-HD-24	24 space	1229 mm	597 mm	470 mm	489 mm	102 mm
ROTR-HD-44	44 space	2118 mm				

* Adjustable to 152 mm with included hardware.

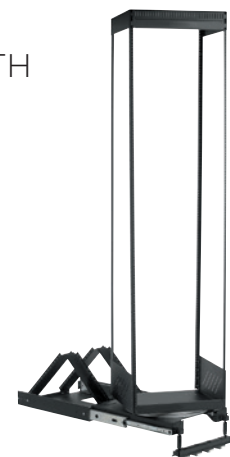

CPROTR CAPTIVE ROTATING RACK

Roll-out rotating rack with metal enclosure. Weight capacity 340 kg.
Rack rails ship separately. Assembly required.

Model	Rack Height	Height	Overall Depth	Usable Depth	Overall Width
CPROTR-42	42 space	2240 mm	711 mm	557 mm	610 mm



ROTATING & PULL-OUT RACK ACCESSORIES



ROTRS	Compatibility
Racks Component Shelf	POTR, POTR-XL, ROTR and ROTR-XL

More universal rack accessories available on page 133.

RAXXESS™ ON-WALL RACK FEATURES

RACKBUILDER™

Customize this rack in RackBuilder to your exact specifications. Details on page 119.

EASY INSTALLATION

Enclosed wall-mounted racks come with horizontal keyhole slots to make hanging the back panel simple.

INCLUDED HARDWARE

Racks ship with all required hardware to mount to wood studs, steel studs or concrete.

W2 Series FIXED WALL RACKS

This fixed wall rack includes a reversible locking front door and a ventilated bottom panel. Steel flanged blanking panel at the top is easily removed to accept any 3U fan or panel. Weight capacity is 68 kg.

Model	Rack Height	Height	Overall Depth	Usable Depth	Width
NW2F818	8 space	468 mm	460 mm	420 mm	562 mm
NW2F1218	12 space	646 mm			



RAXXESS™ FREESTANDING RACK FEATURES

BACK TO BASICS

Clean, efficient rack design for audio and video gear.

INSTALLER FRIENDLY

Ships knocked down to assemble in minutes.

ER ECONOMY RACKS

An economical rack available in heights from 4 space to 20 space and 403 mm or 454 mm depths. Weight capacity is 68 kg.

Model	Rack Height	Height	Overall Depth	Usable Depth	Overall Width
ER-4	4 space	219 mm	403 mm	381 mm	772 mm
ER-6	6 space	308 mm			
ER-8	8 space	397 mm			
ER-10	10 space	486 mm			
ER-12	12 space	574 mm			
ER-14	14 space	664 mm			
ER-16	16 space	753 mm			
ER-20	20 space	930 mm	454 mm	431 mm	772 mm
ER-8-18	8 space	397 mm			
ER-16-18	16 space	753 mm			



ERK ELITE RACKS

Sectional design allows access to rear of rack for cabling and maintenance.

Doors can be hinged to open in either direction. Weight capacity is 68 kg. All racks over 8 space include casters.

Model	Rack Height	Height	Height w/ Casters	Overall Depth	Usable Depth	Overall Width	Color
ERK-4-16B	4 space	229 mm	302 mm	406 mm	356 mm	772 mm	B
ERK-8-20B	8 space	429 mm	502 mm	508 mm	457 mm		B
ERK-12-20B	12 space	606 mm	680 mm				B
ERK-16-20B	16 space	784 mm	857 mm	B			



FREESTANDING RACK ACCESSORIES



ER Plexi Economy Rack Door Options		
Model	Non Slanted Rack Height	Type
ERD-8	8 space	Plexi
ERD-12	12 space	Plexi
ERD-16	16 space	Plexi
ERD-20	20 space	Plexi



ERK Rack Rear Door Options		
Model	Rack Height	Color
ERKD-8BR	8 space	B
ERKD-12BR	12 space	B
ERKD-16BR	16 space	B
ERKD-20BR	20 space	B



ERK Rack Front Door Options		
Model	Rack Height	Type
ERKD-8	8 space	Plexi
ERKD-12	12 space	Plexi
ERKD-16	16 space	Plexi
ERKD-20	20 space	Plexi



CASTER-ER/ERK	Compatibility
Casters	ER Racks, ERS Racks and ERK-4 and ERK-8

OTHER RAXXESS™ RACK ACCESSORIES

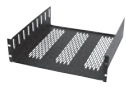

NACS Custom Mounting Shelves		
Model	Rack Height	Depth
NACS214*	2 space	355 mm
NACS218	2 space	457 mm
NACS314**	3 space	355 mm
NACS318	3 space	457 mm
NACS414	4 space	355 mm
NACS418	4 space	457 mm
NACS514	5 space	355 mm
NACS518	5 space	457 mm
NACS614	6 space	355 mm
NACS618	6 space	457 mm

NACF Custom Faceplates
Combine NACS custom mounting shelf with NACF custom faceplate. Visit chiefmfg.com for complete list of custom faceplate options.

* Popular components include Apple TV Gen3, Dual, Triple, and Sonos Connect Single, Dual, Triple.

** Popular components include Sonos Connect AMP Single and Dual.



CMK-CBS Component Clamping Bars for Custom Mounting Shelves
Works with NACS selves to secure products in place. Includes soft foam protective strips.



UNS-1	Rack Height	Depth
Universal Rack Shelf	1 space	254 mm



UTS Utility Shelf		
Model	Rack Height	Depth
UTS-1	1 space	279 mm
UTS-2	2 space	368 mm
UTS-3	3 space	368 mm
UTS-4	4 space	368 mm



UTVS-3-18	Rack Height	Depth
Vented Shelf	3 space	457 mm



TR Trap Shelf		
Model	Rack Height	Depth
TR-2	2 space	368 mm
TR-3	3 space	368 mm



ATS-16-26	Rack Height	Depth
Adjustable Telescoping Shelf	1 space	406 - 606 mm



EXS Extendable Shelf		
Model	Usable Depth	Weight Capacity
EXS-2	533 - 711 mm	45.4 kg



SLS-1.5	Rack Height	Depth
Sliding Shelf	2 space	368 mm



AFG Aluminum Flanged Panel		
Model	Rack Height	Type
AFG-1	1 space	Black Anodized Aluminum
AFG-2	2 space	Black Anodized Aluminum
AFG-3	3 space	Black Anodized Aluminum
AFG-4	4 space	Black Anodized Aluminum



AFT Aluminum Flat Panel		
Model	Rack Height	Type
AFT-1	1 space	Black Anodized Aluminum
AFT-2	2 space	Black Anodized Aluminum

OTHER RAXXESS™ RACK ACCESSORIES



EFG Economy Steel Flanged Panel		
Model	Rack Height	Type
EFG-1	1 space	Black Powder Coat
EFG-2	2 space	Black Powder Coat
EFG-3	3 space	Black Powder Coat
EFG-4	4 space	Black Powder Coat



SFG Steel Flanged Panel		
Model	Rack Height	Type
SFG-1	1 space	Black Wrinkle Coat
SFG-2	2 space	Black Wrinkle Coat
SFG-3	3 space	Black Wrinkle Coat
SFG-4	4 space	Black Wrinkle Coat



FVP Fine Perforated Vent Panel		
Model	Rack Height	Type
FVP-1	1 space	Black Powder Coat



PVP Perforated Vent Panel		
Model	Rack Height	Type
PVP-1	1 space	Black Powder Coat
PVP-2	2 space	Black Powder Coat
PVP-3	3 space	Black Powder Coat
PVP-4	4 space	Black Powder Coat



LSC Locking Security Cover		
Model	Rack Height	Type
LSC-4	4 space	Solid Steel



SEC Perforated Security Cover		
Model	Rack Height	Type
SEC-1	1 space	Black Powder Coat
SEC-2	2 space	Black Powder Coat
SEC-3	3 space	Black Powder Coat



SDR Sliding Drawer Options		
Model	Rack Height	Type
SDR-2-L	2 space	Locking
SDR-3-L	3 space	Locking
SDR-4-L	4 space	Locking



FL	Compatibility
Floor Levelers	Compatibility E1, G1, (S1 ships with floor levelers)



NAC25H	Compatibility
Heavy Duty Casters	E1, G1, S1



PTSW-(X) Rack Screws	
Model	Quantity
PTSW25	Package of 25
PTSW50	Package of 50
PTSW100	Package of 100
PTSW500	Reuseable bucket of 500



PNTX-(X)	Compatibility
Security Screws	All Racks
Model	Quantity
PNTX-25	Package of 25, includes one security bit
PNTX-50	Package of 50, includes one security bit
PNTX-100	Package of 100, includes one security bit
PNTX-B	Extra Security Screw Bit

OTHER RAXXESS™ RACK ACCESSORIES



NALRBW	Compatibility
Rack Light	Included 12VDC power supply accepts 120/240 and 50/60Hz



TB	
Horizontal tie bars for organizing cables	
Model	Description
TBA	25 mm Wide Aluminum
TBL	13 mm L-Shaped
TBLO	102 mm Offset L-Shaped
TBS	6 mm Round Rod
TBO	102 mm Offset Round Rod



LCS Cable Lacing Strips		
Vertical lacing strips can be field cut to size		
Model	Width	Length
LCS	50.8 mm	1960 mm
LCS-1	24.4 mm	1960 mm



NAG Brush Grommet	
Model	Rack Height
NAG1BW	1 space
NAG2BW	2 space



CT	
Nylon zip ties in packs of 100	
Model	Length
CT-100-4	102 mm
CT-100-8	203 mm
CT-100-12	305 mm
CT-100-15	381 mm
CT-100-8R	203 mm reusable



CMP-1C	Rack Height
Large Loop Cable Management Panel	1 space



CMP-1M	Rack Height
Small Loop Cable Management Panel	1 space



NAF15BA	Rack Height	Description	Type
Fan Panel	1U	Intake fan panel for front rail installation	Quiet



NAFT85	Description
Thermostat Control	Turns on at 29° C off at 24° C. Includes universal power supply to run two fans.

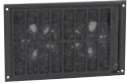

NAFB2BW	Description	Compatibility
Filtered Fan Panel	Draws cool filtered air into rack from bottom	E1, F1, G1, S1 racks



NAV8B	Quantity	Compatibility
Vent Block Kit	8	E1, W1, W2



NAF Exhaust Fan Panel - Black Anodized			
Model	Rack Height	Fans	Type
NAF31QBA	3 space	1	Quiet
NAF32QBA	3 space	2	Quiet
NAF33QBA	3 space	3	Quiet

OTHER RAXXESS™ RACK ACCESSORIES



NAM1F	Rack Height	Mounting Patterns (W,H)	Weight Capacity
Fixed Rack Monitor Mount	4 space rack mount*	75 x 75 mm to 200 x 100 mm	18 kg



NAM1T	Rack Height	Mounting Patterns (W,H)	Weight Capacity
Tilt Rack Monitor Mount	4 space rack mount*	75 x 75 mm to 100 x 100 mm	18 kg



NAM1A	Rack Height	Mounting Patterns (W,H)	Weight Capacity
Articulating Rack Monitor Mount	4 space rack mount*	75 x 75 mm to 100 x 100 mm	18 kg



Pull-Out iPod® Docks		
Includes iPod Dock, Multi-Function Remote Control, 120V/240V Power Supply, Zip Ties, Audio, Video and USB Cables		
Model	Rack Height	Color
NAID1B	1 space	B
NAID4B	4 space	B



NADBW	Size
Document Holder	Holds documents up to 216 x 279 mm

INDEX

2015 EMEA CATALOG

A

AFG 140
 AFT 140
 AN2BA 35
 AN2BA87 35
 AN2BA100 35
 ATS-16-26 140

C

CASTER-ER 139
 CASTER-ERK 139
 CM2C40UI 75
 CM2L40UI 88
 CMA110 24
 CMA115W 73
 CMA274 23, 73, 74
 CMA275 73, 74
 CMA330 23, 73
 CMA345 23, 73
 CMA347 23
 CMA351 24, 73
 CMA360 73
 CMA365 73
 CMA395 23, 73
 CMA395W 73
 CMA640 24, 73
 CMA643 24, 73
 CMK-CBS 140
 CMP-1C 142
 CMP-1M 142
 CMS003 24
 CMS006 24
 CMS009 24
 CMS012 24
 CMS018 24
 CMS024 24
 CMS036 24
 CMS048 24
 CMS060 24
 CMS072 24
 CMS115 23, 73
 CMS0203 24
 CMS0305 24
 CMS0406 24
 CMS440 24
 CMS491 24
 CMS491C 24
 CMS492 24
 CMS492C 24
 CMS0507 24
 CMS006009 24
 CMS009012 24
 CMS012018 24
 CMS018024 24

CMS Adjustable Columns 24, 73
 CMS Fixed Columns 73, 24
 CMSH3 34
 CMSZ006 24
 CPA116 23
 CPA262 74
 CPA262S 74
 CPA263 23, 74
 CPA264 23, 74
 CPA330 23, 74
 CPA365 23, 74
 CPA395 23, 74
 CPA640 23
 CPA Columns 74
 CPAE 23
 CPAE030 23, 74
 CPAE080 23, 74
 CPAE100 23
 CPAE150 23, 74
 CPAE300 23, 74
 CPROTR 136
 CT 142

E

EFG 141
 ER 138
 ERD 139
 ERK 138
 ERKD 139
 EXS-2 140

F

FCA2X1U 82
 FCA3U 71
 FCA3X1U 82
 FCA4U 71
 FCA100 54
 FCA101 39, 46
 FCA102 39, 46
 FCA103 39, 46
 FCA104 40, 47
 FCA106 40, 47
 FCA500 71, 82, 86
 FCA501 71, 82, 86
 FCA502 71, 82
 FCA510 71, 83, 86
 FCA515 86, 71
 FCA520 86, 72
 FCA530 72, 83, 87
 FCA535 82, 83, 72
 FCA611 86
 FCA612 86
 FCA623 86
 FCA650 86

FCA651 86
 FCA776 83
 FCA800 39, 46, 54, 71, 82, 86
 FCA801 39, 46, 54, 71, 82, 86
 FCA810 39, 46, 54, 71, 82, 86
 FCA811 39, 46, 54, 71, 82, 86
 FCA820 39, 54, 71, 82, 86
 FCA821 39, 46, 54, 71, 82, 86
 FCA830 39, 46, 54, 72, 83, 87
 FCA831 39, 46, 54
 FCA840 39, 46, 54, 72, 83, 87
 FCA841 39, 54, 72, 83, 87
 FCABX36 82
 FCAC 71
 FCACLIPS 72, 83, 87
 FCAX08 71
 FCAX14 71
 FCAX20 71
 FCC100 39, 46
 FCD100 40, 47
 FCK000 39, 46
 FCK008 39, 46
 FCK016 39, 46
 FCS100 39, 47
 FL 141
 FLR100 39, 46
 FSB4090B 100
 FSB12B 97, 100, 104, 108, 111, 114, 119, 122
 FSB12TB 97, 100, 104, 108, 111, 114, 119, 122
 FSBV 97, 100, 104, 108, 111, 114, 119, 122
 FSR12T 124
 FSRV 42
 FTRV 49
 FVP 141
 FVS100 40, 47
 FVS150 40, 47
 FVS200 40, 47
 FVS250 40, 47
 FVS251 40, 47
 FVS300 40, 47
 FVS350 40

H

HCI 25

I

IR10 28, 77

J

JPPU 76

K

KOP100 122
 KOW100 114
 KOW100BXi2B 124
 KOW100BXi2TB 124
 K1C22H 94
 K1C110 95
 K1C120 94
 K1C120BXi2B 125
 K1C210 94
 K1C220 94
 K1D22H 95
 K1D120 96
 K1D130 96
 K1D220 95
 K1D220BXi2B 125
 K1D230 95
 K1P22H 117
 K1P120 118
 K1P220 117
 K1W22H 110
 K1W120 110
 K1W220 110
 K2C22H 98, 99
 K2C120 99
 K2C220 98
 K2P22H 120
 K2P110 121
 K2P120 121
 K2P220 120
 K2W22H 112
 K2W110 113
 K2W120 113
 K2W220 112
 K3F120B 103
 K3F220B 102
 K3F310B 103
 K3G120B 103
 K3G220B 102
 K3G310B 103
 K3G320B 102
 K4G120B 106
 K4G210B 106
 K4G310B 106
 K4G320B 107
 K4G410B 106
 K4G420B 107
 K4G510B 105
 K4G520B 107
 K4G610B 105
 K4G620B 107
 K4W120B 116
 K4W210B 115
 K4W310B 115

KFA220 91
 KFA225 91
 KFA320 91
 KFA325 91
 KITEC030045 19
 KITEC045080 19
 KITEC080135 19
 KITMZ006S 6, 6
 KRA219 97, 100, 111
 KRA220 97, 100, 111
 KRA221 100
 KRA223 97, 100, 111
 KRA224 97, 100, 111
 KRA225 97, 100
 KRA300 97, 111, 119
 KRA400B 97, 111, 119
 KRA401B 97, 111, 119
 KRA500 104
 KSA1250 104, 108
 KSA1250B 97, 100, 111, 114, 119, 122

L

LBM2x2U 81
 LBM2x2UP 81
 LBM3x1UP 80
 LBM3x2U 80
 LBM3x2UP 80
 LBM3x3U 79
 LC1 25
 LCB1U 68
 LCB1UP 68
 LCB1x2U 69
 LCB2x1U 65
 LCB2x1UP 65
 LCB3x1U 64
 LCB3x1UP 64
 LCD2C 25
 LCD2TS 25
 LCDCP 25
 LCDPA 25
 LCM1U 67
 LCM1UP 68
 LCM1x2U 69
 LCM2x1U 64
 LCM2x1UP 65
 LCM2x2U 62
 LCM2x2UP 62
 LCM3U 69
 LCM3x1U 63
 LCM3x1UP 63
 LCM3x2U 61
 LCM3x2UP 61
 LCM3x3U 61
 LCM4U 69
 LCS 142

LFAU 85
 LPAU 85
 LSA1U 37
 LSC-4 141
 LSM1U 37
 LSMVPU 52
 LSMVU 52
 LSTU 41
 LTA1U 44
 LTM1U 44
 LTTU 48
 LVM2x2U 81
 LVM2x2UP 81
 LVM3x1UP 80
 LVM3x2U 79
 LVM3x2UP 79
 LVM3x3U 79
 LVSIU 51
 LVSIUP 51
 LVXSU 51
 LVXSUP 51

M

MAC722 91
 MCB1U 70
 MCB1x2U 70
 MCM1U 70
 MCM1x2U 70
 MF1U 90
 MFAU 85
 MFCU 89
 MPAU 85
 MSA1U 38
 MSM1U 38
 MSMVPU 53
 MSMVU 53
 MSTU 41
 MTA1U 45
 MTM1U 45
 MTMPIU 45
 MTTU 48
 MWCU 49

N

NAC25H 141
 NACF 140
 NACS 140
 NADBW 143
 NAF 142
 NAF15BA 142
 NAFB2BW 142
 NAFT85 142
 NAG 142
 NAID1B 143

NAID4B 143
 NALRBW 142
 NAM1A 143
 NAM1F 143
 NAM1T 143
 NAS1S 128
 NAV8B 142
 NE1D 132
 NE1F 131, 132
 NG1D 130
 NG1F 129, 130
 NG1S 130
 NS1D 128
 NS1F 127, 128
 NS1S 128
 NW2F 137

O

OFBLU 114
 OFBU 114
 OFB-xxx 114

P

PAC101 42
 PAC102 77
 PAC103 42
 PAC710 91
 PAC715 59, 77, 91
 PAC716 59, 77, 91
 PAC722 91
 PAC730A 91
 PACCS1 59
 PACTP1 91
 PDRUB 59
 PFIU 89
 PFCU 89
 PG1A 25
 PG2A 25
 PG3A 25
 PNRUB 59
 PNTX 141
 POTR 135
 POTR-XL 135
 PSMH 42
 PTSU 92
 PTSW 141
 PVP 141

R

RackBuilder 126
 ROTR 135
 ROTR-HD 135
 ROTRS 136
 ROTR-XL 135
 RPEU 21
 RPMEU 20
 RSEU 21
 RSMEU 20

S

SEC 141
 SEC2 25
 SFG 141
 SL15i 27
 SL220 27
 SL236i 27
 SLS-1.5 140
 STLU 92
 STS1 92

T

TA100 58
 TA200 58
 TA250 58
 TA300 58
 TA350 58
 TA410 58
 TB 142
 TPMU 76
 TPSU 76
 TR 140
 TS110SU 57
 TS118SU 57
 TS218SU 57
 TS318SU 56
 TS318TU 56
 TS325TU 56
 TS525TU 56

U

UNS-1 140
 UTS-1 140
 UTS-2 140
 UTS-3 140
 UTS-4 140
 UTVS-3-18 140

V

VCMEU 22

W

WM110AUS 31
 WM120AUS 31
 WM130AUS 31
 WM210AUS 30
 WM220AUS 30
 WM230AUS 30
 WMA1S 34
 WMA2S 34
 WMAH3S 32
 WP21US 33
 WP22US 33
 WP23US 33

X

XCB1U 67
 XCB7000 66
 XCM1U 67
 XCM7000 66
 XPAU 84
 XSM1U 37
 XTM1U 44
 XVAU 84

Y

YAMF1 133
 YF1F 133

TERMS & CONDITIONS

PRICES: Prices are subject to change without notice. Orders are priced at the pricing in effect on the date your purchase order was received. To guarantee pricing for a specific period, customer must obtain a written quotation from Chief. Chief only sells directly to authorized Chief dealers and distributors. Possession of said price book does not constitute an offer to sell.

TERMS AND CONDITIONS: All accounts are due and payable in funds according to the terms of the invoice.

ORDERING: Because of the specific nature of our products and our commitment to entering and shipping orders accurately, we prefer that orders be placed in writing via a purchase order and sent to us via fax (+31 495 580 845) or via e-mail (emea.sales@milestone.com). In urgent situations, we will make every effort to take accurate orders verbally when requested by the customer. Chief cannot guarantee that verbal miscommunication errors will result in the purchaser's favor.

ORDER CONFIRMATION: Customers will receive an E-mail confirmation of their order within 5 hours of receipt of purchase order or at end working day max. within 24 hours. If you do not receive a confirmation of your order, please contact us as it is possible we did not receive your original order. Please review the confirmation to ensure Chief has recorded the details of the transaction as you expected and notify Chief of any discrepancies immediately.

CHANGES TO ORDERS: Because expedited orders begin the production and shipping fulfillment process immediately upon receipt and entry of purchase order, it is frequently not possible to change orders. Other orders will be changed as possible. Contact Customer Service at +31 495 580 840 and they will work through an alternative solution with you. In all cases, the customer is responsible for incremental charges incurred because of the change.

SPECIAL ORDERS: Some of Chief's products can be customized to fit your specific applications. Contact Inside Sales for additional information and pricing. Orders for large quantities of products may also be considered a special order. Any special order or custom product not normally carried in inventory cannot be returned. All electrical products and products with quote pricing are treated as special order items.

PRODUCT CHANGES/DISCONTINUED PRODUCTS: Chief is constantly developing new products and making improvements to existing ones; therefore, we reserve the right to revise or change specifications, designs and model numbers and to discontinue models without notice.

PACKAGING: Where possible and practical, Chief will bulk-pack the items on your order. Please keep in mind that the dimensions and weight of some of our products may preclude bulk-packing. We are not responsible for air-freight or other charges due to multiple single package shipments.

DELIVERY: All promises of delivery are made in good faith and every reasonable effort is made to see that delivery schedules are met. However, if Chief is unable to meet a schedule due to factors beyond our control such as, but not limited to, failure of our suppliers to meet their promised dates or weather related delivery delays, Chief will not be responsible for significant or specific damage. Significant or specific damages may be, but are not limited to, express shipping method charges or installation delay charges. Contact the Chief Inside Sales team for assistance with freight estimates specific to your needs. Delivered prices do not include any type of extraordinary charges such as lift gate requirements, inside delivery charges, residential charges or other nonstandard charges.

FREIGHT AND FREIGHT DAMAGE: Depending on the Inco-term. It is the customer's responsibility to immediately open and inspect all packages and, in the event there is any damage or shortages, file a claim with the freight company. Please contact Chief Customer Service at +31 495 580 840 to get contact information about the specific freight company used and to discuss receiving a replacement product. Keep the damaged product in its original packaging and carton. Unless concealed damage is reported to the Carrier and Chief immediately, there is no recourse. The customer will be charged for any replacement product as the eventual credit will come directly from the carrier via the claim filed.

RETURNS AUTHORIZATION: All merchandise returned to Chief must be returned with prior authorization and a Return Authorization number provided by Customer Service. Chief will provide Return Authorization only for those products purchased directly from Chief. Consumers or dealers purchasing through a third party must request returns through that third party and are subject to that entity's return policies and charges. Defective or product received incorrectly due to an error on Chief's part will be credited to your account in full. In situations where the dealer needs to return merchandise due to a change in its project/equipment or due to ordering incorrectly, a restock charge will apply as follows. Returns are not allowed for merchandise over 90 days old; electrical lift products; special order products, or discontinued merchandise. Products returned that are damaged or missing parts will not be eligible for credit unless they can easily be made saleable. Additional charges for parts and labor may apply.

LIMITED WARRANTY: With the exception of electrical products, Chief warrants its products to be free of defects in material and workmanship for 10 years. All warranties are in effect beginning the date the product was invoiced by Chief. Electrical mechanisms (such as lift products) have a 1-year limited warranty. All warranties are in effect for the original purchaser only. Chief disclaims liability for any modifications, improper installation and/or installations over the specified weight capacity. Chief also disclaims liability for any modifications made to electrical mechanisms, improper installation, incorrect voltage connection and/or installations over the stated weight capacity. All Electrical Mechanisms are intended for indoor use only and failure to comply will void warranty. Chief's sole warranty obligation to the owner of its products is to repair or replace (at Chief's discretion) defective products at no charge to the original purchaser within the warranty period. The purchaser is responsible for returning the product to Chief via prepaid shipping. To the maximum extent permitted by applicable law, Chief disclaims any other warranties, express or implied, including warranties of fitness for a particular purpose and warranties of merchantability. Chief will not be liable for any damages whatsoever arising out of the use or inability to use Chief products, even if Chief has been advised of the possibility of such damages. Chief bears no responsibility for incidental or consequential damages. This includes, but is not limited to, any labor charges for the repair of Chief products performed by someone other than a Chief employee. Because some states and jurisdictions do not allow the exclusion or limitation of liability for consequential or incidental damages, the above limitation may not apply. Chief will not be responsible for damage to Chief products caused by misuse, abuse, failure to properly package the product for return to Chief or for damage caused by carriers during shipment to or from Chief. Any repairs to Chief products required due to misuse, abuse or shipping damage or repairs of defective Chief product outside the warranty period will be performed at the current rates established by Chief for factory service.

 **CHIEF** A BRAND OF MILESTONE AV TECHNOLOGIES ■ www.chiefmfg.com

EMEA P +31 495 580 840 ■ F +31 495 580 845 ■ emea.sales@milestone.com

USA P 800.582.6480 / +1.952.225.6000 ■ F 877.894.6918 / +1.952.894.6918 ■ chief@chiefmfg.com

Canada P 877.345.4329 ■ F 888.377.5314 ■ canadainfo@milestone.com

Asia Pacific P +852 2145 4099 ■ F +852 2145 4477 ■ asia.chief@milestone.com