



Digital Projector

User Manual

LW855UST / LH856UST

VI.00

Warranty and Copyright information

Limited warranty

BenQ warrants this product against any defects in material and workmanship, under normal usage and storage.

Proof of purchase date will be required with any warranty claim. In the event this product is found to be defective within the warranty period, BenQ's only obligation and your exclusive remedy shall be replacement of any defective parts (labor included). To obtain warranty service, immediately notify the dealer from which you purchased the product of any defects.

Important: The above warranty shall be void if the customer fails to operate the product in accordance with BenQ's written instructions, especially the ambient humidity must be in-between 10% and 90%, temperature in-between 0°C and 35°C, altitude lower than 4920 feet, and avoiding to operate the projector in a dusty environment. This warranty gives you specific legal rights, and you may have other rights which vary from country to country.

For other information, please visit www.BenQ.com.

Copyright

Copyright 2023 BenQ Corporation. All rights reserved. No part of this publication may be reproduced, transmitted, transcribed, stored in a retrieval system or translated into any language or computer language, in any form or by any means, electronic, mechanical, magnetic, optical, chemical, manual or otherwise, without the prior written permission of BenQ Corporation.

Disclaimer

BenQ Corporation makes no representations or warranties, either expressed or implied, with respect to the contents hereof and specifically disclaims any warranties, merchantability or fitness for any particular purpose. Further, BenQ Corporation reserves the right to revise this publication and to make changes from time to time in the contents hereof without obligation to notify any person of such revision or changes.

*DLP, Digital Micromirror Device and DMD are trademarks of Texas Instruments. Others are copyrights of their respective companies or organizations..

Table of Contents

Warranty and Copyright information	2
Important safety instructions.....	4
Notice on laser	8
Introduction.....	9
Projector features	9
Shipping contents	10
Projector exterior view.....	11
Controls and functions.....	12
Positioning your projector	15
Using the Quick Install.....	15
Obtaining a preferred projected image size.....	17
Limited lens shift specification (No available in LH856UST).....	18
Mounting the projector	19
Dimensions	21
Connection	22
Connecting video source devices	23
Connecting audio	23
Connecting smart devices	23
Playing sound through the projector	24
Operations.....	25
Starting up the projector.....	25
Adjusting the projected image.....	26
Using the menus	29
Securing the projector	30
Switching input signal.....	31
Installing PointWrite module on projector to use interaction function	32
Shutting down the projector	33
Menu operation.....	34
Menu System	34
Maintenance	50
Care of the projector.....	50
Indicators.....	51
Troubleshooting	52
Troubleshooting.....	52
Specifications.....	53
Projector specifications	53
Timing table	54
RS232 command control	58
PJLink.....	65

Important safety instructions

Your projector is designed and tested to meet the latest standards for safety of information technology equipment. However, to ensure safe use of this product, it is important that you follow the instructions mentioned in this manual and marked on the product.

1. **Please read this manual before you operate your projector.** Save it for future reference.

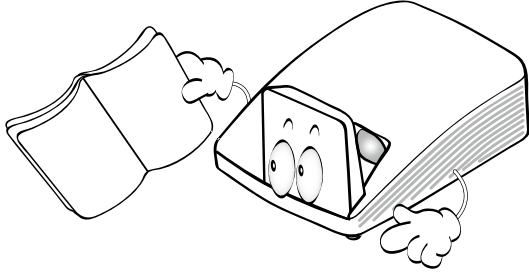

2. **Do not look straight at the projector lens during operation.** The intense light beam may damage your eyes.

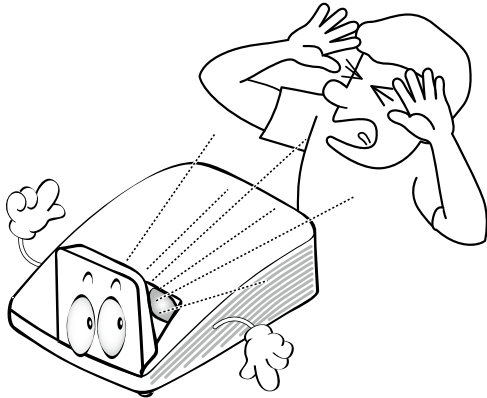

3. **Refer servicing to qualified service personnel.**

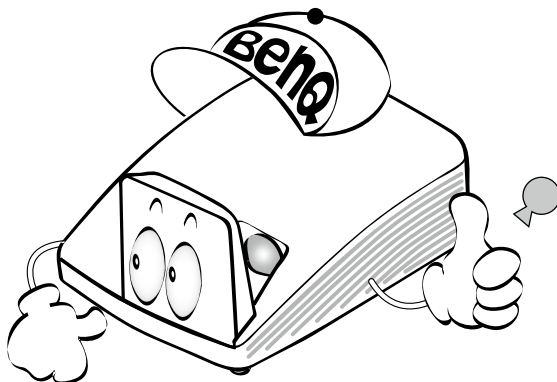

4. In some countries, the line voltage is NOT stable. This projector is designed to operate safely within a mains voltage between 100 to 240 volts AC, but could fail if power cuts or surges of ± 10 volts occur. **In areas where the mains voltage may fluctuate or cut out, it is recommended that you connect your projector through a power stabilizer, surge protector or uninterruptible power supply (UPS).**

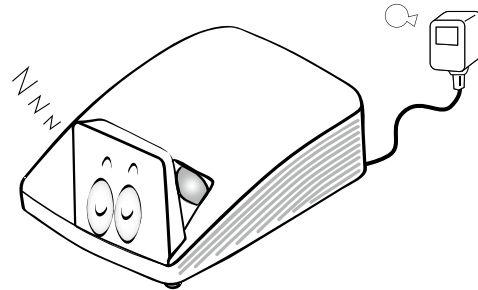

5. Do not block the projection lens with any objects when the projector is under operation as this could cause the objects to become heated and deformed or even cause a fire. To temporarily turn off the light source, press **ECO BLANK** on the remote control.

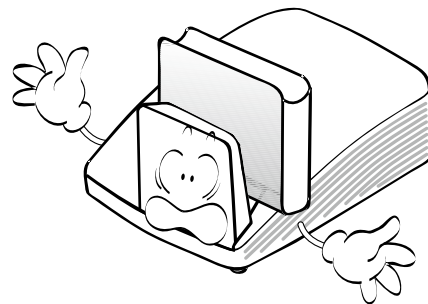

6. Do not operate projector beyond the rated light source life, Excessive operation of light source beyond the rated life could cause them to break on rare occasions.

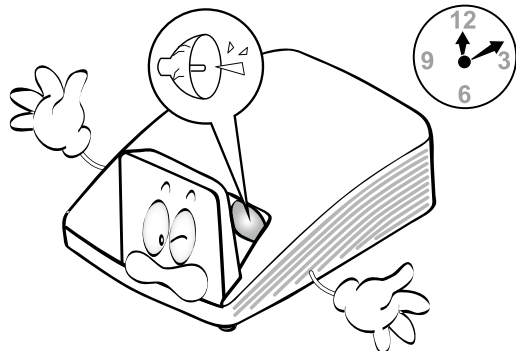

7. Never replace any electronic components unless the projector is unplugged.

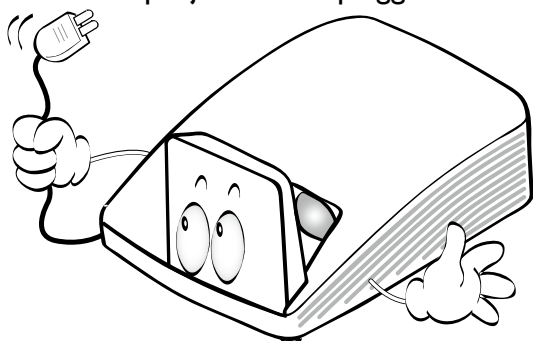

8. Do not place this product on an unstable cart, stand, or table. The product may fall, sustaining serious damage.

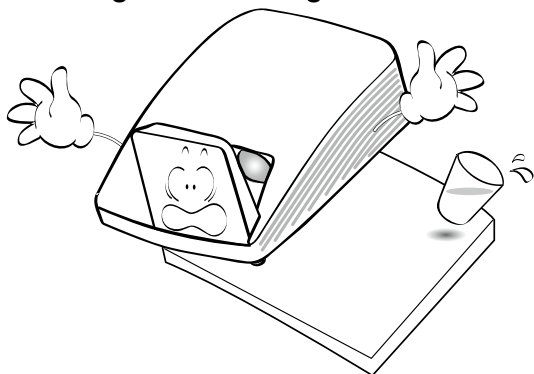

9. Do not attempt to disassemble this projector. There are dangerous high voltages inside which may cause death if you should come into contact with live parts. Under no circumstances should you ever undo or remove any other covers. Refer servicing only to suitably qualified professional service personnel.

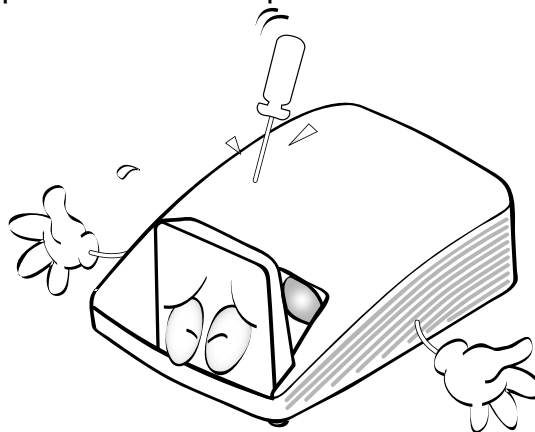

10. When the projector is under operation, you may sense some heated air and odor from its ventilation grill. It is a normal phenomenon and not a product defect.

11. Do not place this projector in any of the following environments.

- Space that is poorly ventilated or confined. Allow at least 50 cm clearance from walls and free flow of air around the projector.
- Locations where temperatures may become excessively high, such as the inside of a car with all windows rolled up.
- Locations where excessive humidity, dust, or cigarette smoke may contaminate optical components, shortening the projector's life span and darkening the image.

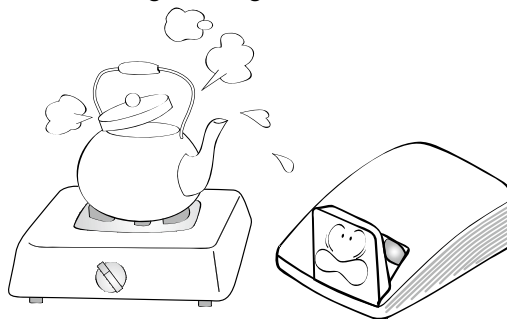

- Locations near fire alarms
- Locations with an ambient temperature above 40°C / 104°F
- Locations where the altitudes are higher than 3000 m (10000 feet).

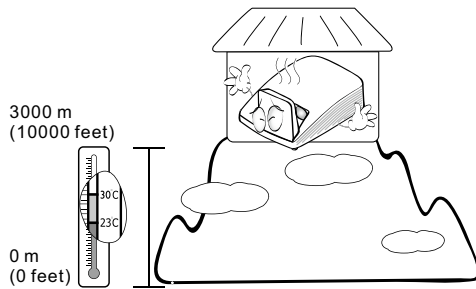

12. Do not block the ventilation holes.

- Do not place this projector on a blanket, bedding or any other soft surface.
- Do not cover this projector with a cloth or any other item.
- Do not place inflammables near the projector.

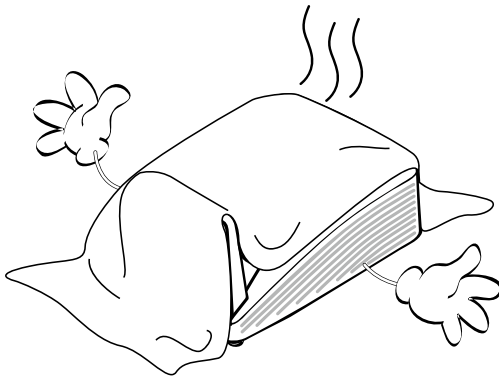

If the ventilation holes are seriously obstructed, overheating inside the projector may result in a fire.

13. Do not stand the projector on end vertically. Doing so may cause the projector to fall over, causing injury or resulting in damage to the projector

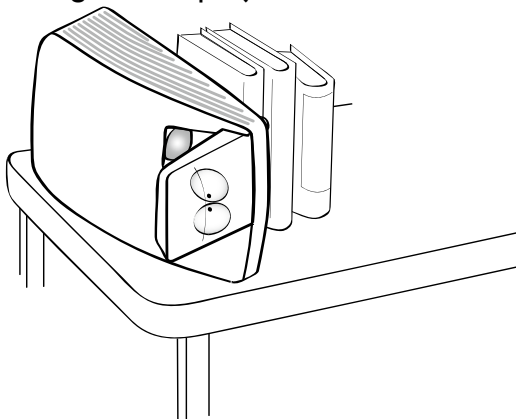

14. Do not step on the projector or place any objects upon it. Besides probable physical damage to the projector, doing so may result in accidents and possible injury.

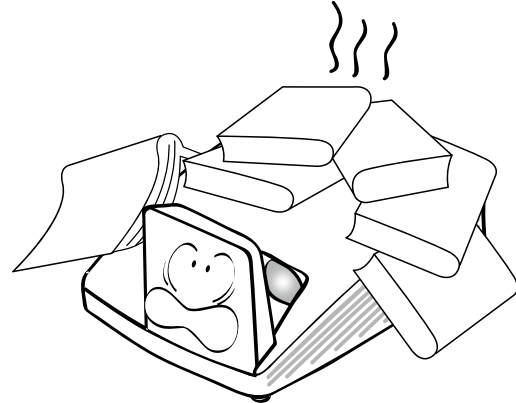

15. Do not place liquids near or on the projector. Liquids spilled into the projector may cause it to fail. If the projector does become wet, disconnect it from the power supply's wall socket and call BenQ to have the projector serviced.

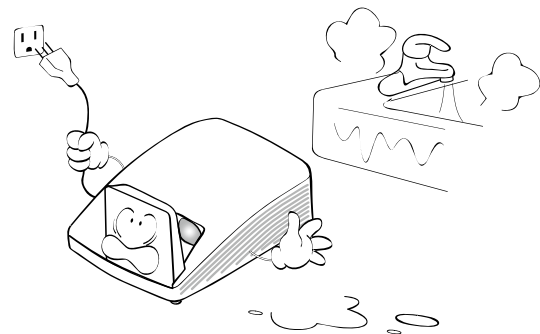

16. This product is capable of displaying inverted images for wall mount installation.

! Use only BenQ's Wall Mount Kit for mounting the projector and ensure it is securely installed.

! **Wall mounting the projector**

We want you to have a pleasant experience using your BenQ projector, so we need to bring this safety matter to your attention to prevent possible damage to person and property.

If you intend to mount your projector on the wall, we strongly recommend that you use a proper fitting BenQ projector wall mount kit and that you ensure it is securely and safely installed.

If you use a non-BenQ brand projector wall mount kit, there is a safety risk that the projector may fall from the wall due to an improper attachment through the use of the wrong gauge or length screws.

You can purchase a BenQ projector wall mount kit from the place you purchased your BenQ projector. BenQ recommends that you also purchase a separate Kensington lock compatible security cable and attach it securely to both the Kensington lock slot on the projector and the base of the wall mount bracket. This will perform the secondary role of restraining the projector should its attachment to the mounting bracket become loose.

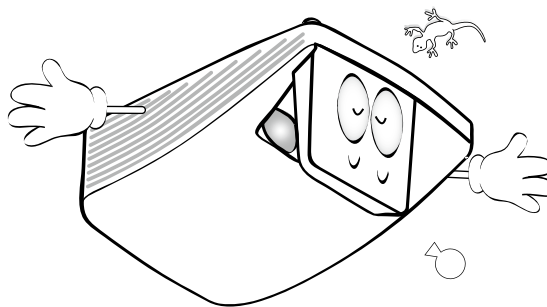

Notice on laser

Caution – use of controls or adjustments or performance of procedures other than those specified herein may result in hazardous radiation exposure.

Do not point laser or allow laser light to be directed or reflected toward other people or reflective objects.

Direct or scattered light can be hazardous to eyes and skin.

There is a potential hazard of eye exposure to laser radiation if the included instructions are not followed.

Do not allow to look into the projector beam at any distance from the projector. An adult should supervise the children to prevent exposure risks.

Check that there is no one looking at the lens, when using the remote control for starting the projector.

Do not look at the projected light using optical devices(binoculars, telescopes, magnifying glasses, reflectors, etc).

Laser class

This Laser Product is designated as Class I and CONSUMER LASER PRODUCT: EN 50689:2021 during all procedures of operation and complies with IEC 60825-1:2014 and EN 60825-1:2014/A11:2021.

Laser parameters

Wavelength	449nm - 461nm (Blue)
Mode of operation	Pulsed, due to frame rate
Pulse width	1.15ms
Pulse repetition rate	120Hz
Maximum laser energy	0.76mj
Total internal power	>100w
Apparent source size	>10mm, at lens stop
Divergence	>100 mili Radian

Introduction

Projector features

The projector offers the following features

- **Interactive capability**

Extend the interactive function with optional PointWrite module.

- **Vertical 2% lens shift (No available in LH856UST)**

Optimize the installation flexibility.

- **Corner fit**

Correct each distorted corner to get a perfect rectangular image.

- **Filter Free**

Filter free design to lower maintenance and operating costs.

- **Network Control**

Integrated RJ45 connector for wired network control allowing management of projector status from a computer using a web browser.

Enable Network Standby mode <2W.

- **Crestron RoomView®, and AMX supported**

The projector supports Crestron eControl and RoomView and AMX allowing you to control and manage equipment from a remote computer via LAN connection.

- **One-key auto-adjustment**

Pressing AUTO on the remote control to show the best picture quality immediately.

- **Built-in 10W x 2 speaker(s)**

Built-in 10W x 2 speaker(s) providing stereo audio when an audio input is connected.

- **Auto Power Off, Signal Power On, Direct Power On**

Auto Power Off function allows the projector to turn off automatically if no input signal is detected after a set period of time. **Signal Power On** function turns on your projector automatically once detecting the signal input and **Direct Power On** boots up the projector automatically when the power is connected.



- The apparent brightness of the projected image will vary depending on the ambient lighting conditions, selected input signal contrast/brightness settings, and is directly proportional to projection distance.

Shipping contents

Carefully unpack and verify that you have all of the items shown below. If any of these items are missing, please contact your place of purchase.

Standard accessories

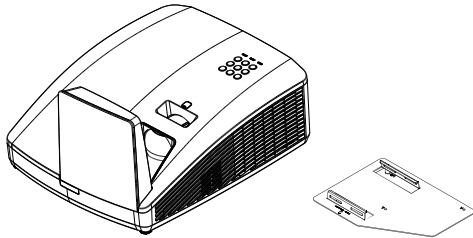

Projector with wall mount plate

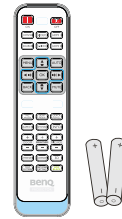

Remote control with battery

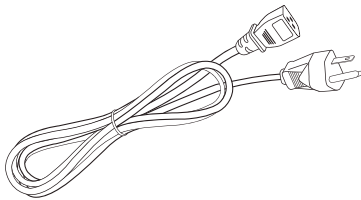

Power cord

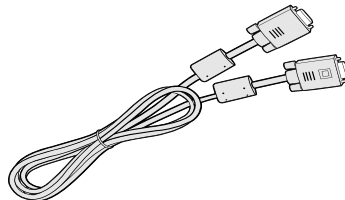

VGA cable

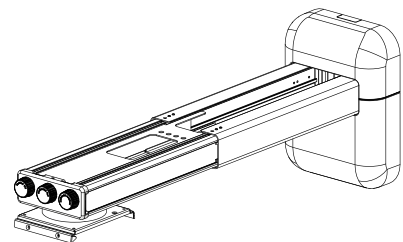

Wall mount kit (WM04G4) & user manual

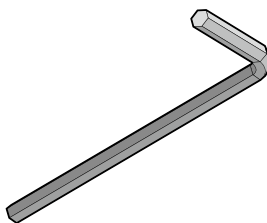

Hex key (2.5mm)**

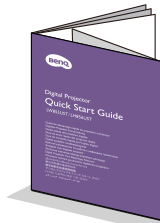

Quick start guide



Warranty card*



Installation chart for wallmount



- The supplied accessories will be suitable for your region, and may differ from those illustrated.
- *The warranty card is only supplied in some specific regions. Please consult your dealer for detailed information.
- **Hex key not available in LH856UST model.

Optional accessories

1. 3D glasses
2. Wireless dongle: QCastMirror (QP30)
3. PointWrite kit (PW30U/PW31U)
4. PointWrite Touch module (PT20)

Projector exterior view

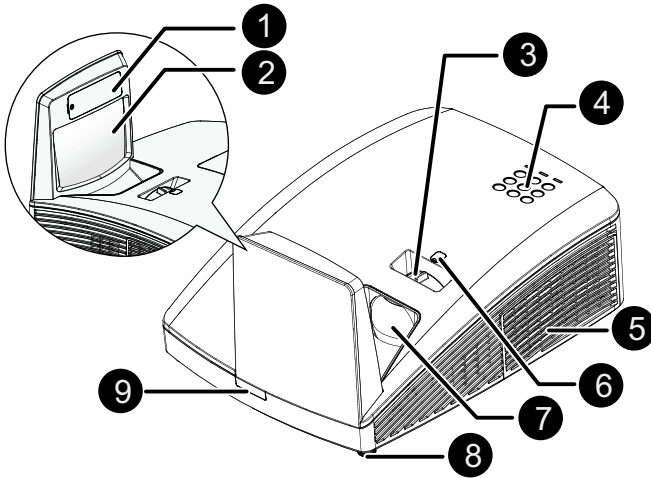

1. PointWrite dummy cover
(Optional PointWrite kit)
2. Mirror
3. Focus ring
4. External control panel
(See ["Projector & Remote control"](#) on page 12 for details.)

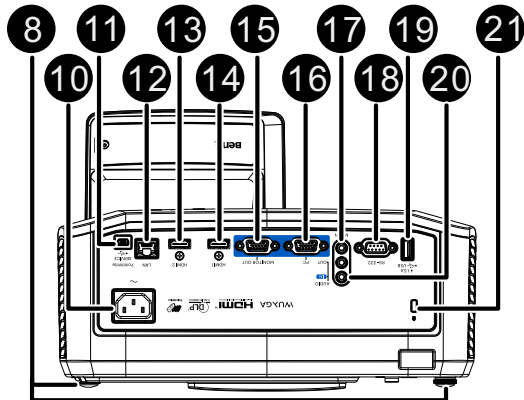

5. Vent (cool air intake)
6. Lens shift
7. Projection lens
8. Front adjuster foot
9. Front IR remote sensor
10. AC power cord inlet
11. PointWrite SERVICE port
(PointWrite kit is required)
12. RJ45 LAN input jack
13. HDMI-2 input jack
14. HDMI-I input jack
15. MONITOR output jack
16. PC input jack
17. MIC input jack
18. RS-232 control port
19. USB Type A (1.5A) port
20. AUDIO IN/OUT jack
21. Kensington anti-theft lock slot

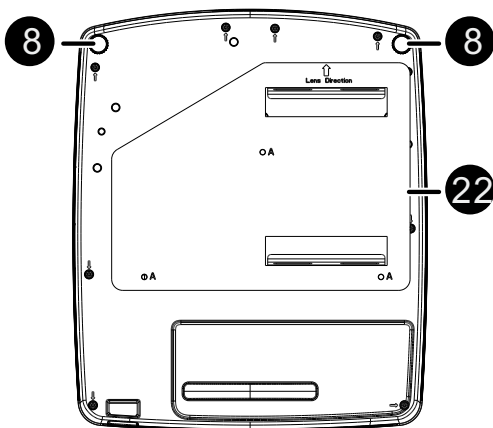

22. Wall mount plate

Controls and functions

Projector & Remote control



- All the key presses described in this document are available on the remote control or projector. **There is no Laser function of the remote for Japan region.
- The remote control is without laser pointer in Japan.

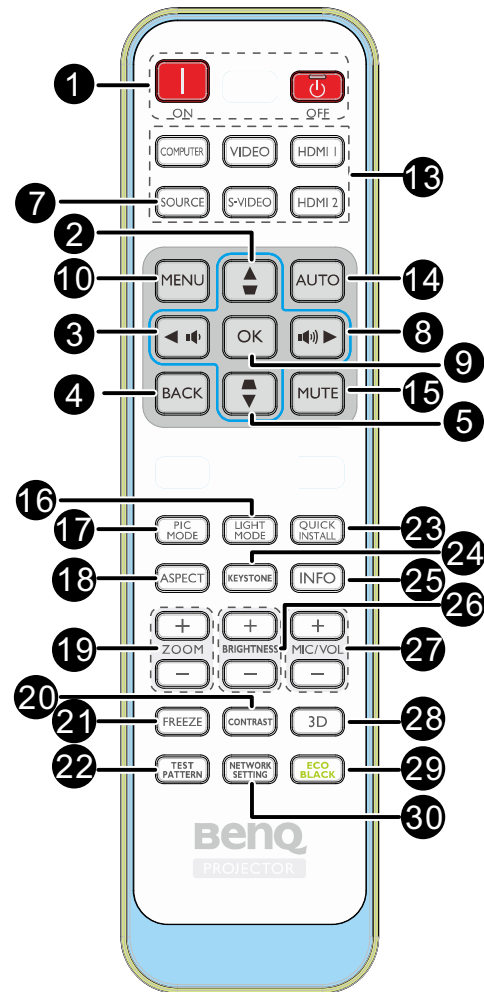
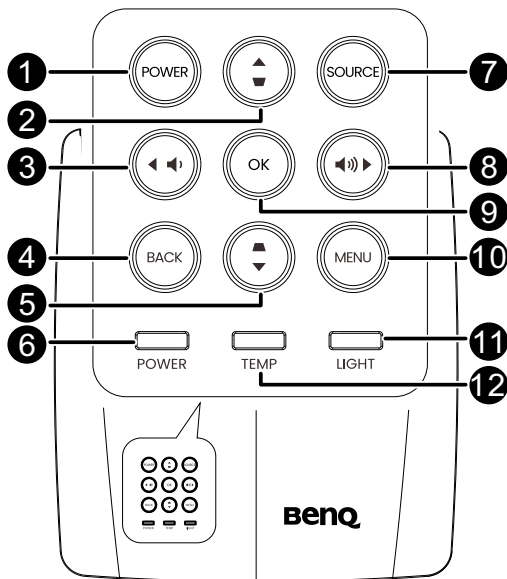

1. POWER

Toggles the projector between standby mode and on.



Toggles the projector between standby mode and on.

2. Keystone/Arrow keys (▼ / ▲ Up)

Manually corrects distorted images resulting from an angled projection.

3. ◀ Left/ ▶ Right

Decreases the projector volume.

4. BACK

Goes back to previous OSD menu, exits and saves menu settings.

5. Keystone/Arrow keys (▲ / ▼ Down)

Manually corrects distorted images resulting from an angled projection.

6. POWER indicator light

Lights up or flashes when the projector is under operation. See ["Indicators" on page 51](#) for details.

7. SOURCE

Displays the source selection bar. See ["Switching input signal" on page 31](#) for details.

8. **► Right/ (Speaker icon))**
Increases the projector volume.
When the On-Screen Display (OSD) menu is activated, the #2, #3, #5, and #8 keys are used as directional arrows to select the desired menu items and to make adjustments. See ["Using the menus" on page 29](#) for details.
9. **OK**
Confirms the selected On-Screen Display (OSD) menu item.
10. **MENU**
Turns on the On-Screen Display (OSD) menu. See ["Using the menus" on page 29](#) for details.
11. **Light source indicator light**
Indicates the status of the light source. Lights up or flashes when the light source has developed a problem. See ["Indicators" on page 51](#) for details.
12. **TEMPerature indicator light**
Lights up red if the projector's temperature becomes too high. See ["Indicators" on page 51](#) for details.
13. **Source selection buttons (COMPUTER, VIDEO, S-Video, HDMI 1/2)**
Selects an input source for display.
14. **AUTO**
Automatically determines the best picture timings for the displayed image. See ["Auto-adjusting the image" on page 26](#) for details.
15. **MUTE**
Toggles projector audio between on and off.
16. **LIGHT MODE**
Press to display OSD menu to select desired light mode.
17. **PIC MODE**
Press to display OSD menu to select Picture mode. See ["Picture Mode" on page 40](#) for details.
18. **ASPECT**
Selects the display aspect ratio.
19. **ZOOM+/ZOOM-**
Magnifies or reduces the projected picture size.
20. **CONTRAST**
Displays the CONTRAST setting bar.
21. **FREEZE**
Freezes the projected image. See ["Test Pattern" on page 46](#).
22. **TEST PATTERN**
Displays the test pattern.
23. **QUICK INSTALL**
Quickly selects several functions to adjust the projected image and displays the test pattern.
24. **KEYSTON**
Display the 2D Keystone page.
25. **INFO**
Displays the projector information.
26. **BRIGHTNESS+/BRIGHTNESS-**
Displays the BRIGHTNESS setting bar.
27. **MIC/VOL +/MIC/VOL -**
Microphone input level adjustment.
28. **3D**
Press to display 3D setup menu.
29. **ECO BLANK**
Used to hide the screen picture.
 Do not block the projection lens from projecting as this could cause the blocking object to become heated and deformed or even cause a fire.
30. **NETWORK SETTING**
Displays the **Network Settings** OSD menu.

Replacing the remote control battery

1. To open the battery cover, turn the remote control over to view its back, push on the finger grip on the cover and slide it up in the direction of the arrow as illustrated. The cover will slide off.
2. Remove any existing batteries (if necessary) and install two AAA batteries observing the battery polarities as indicated in the base of the battery compartment. Positive (+) goes to positive and negative (-) goes to negative.
3. Refit the cover by aligning it with the base and sliding it back down into position. Stop when it clicks into place.

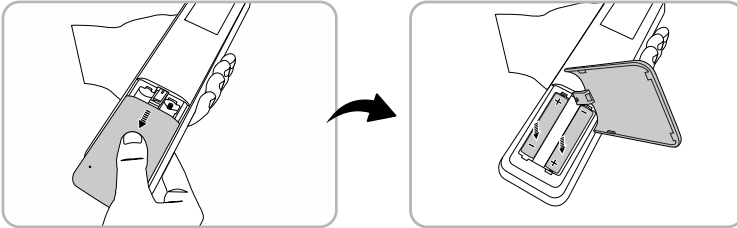

- Avoid excessive heat and humidity.
- There may be battery damage if the battery is incorrectly replaced.
- Replace only with the same or equivalent type recommended by the battery manufacturer.
- Dispose of the used battery according to the battery manufacturer's instructions.
- Never throw a battery into a fire. There may be danger of an explosion.
- If the battery is dead or if you will not be using the remote control for a long time, remove the battery to prevent damage to the remote control from possible battery leakage.

Remote control effective range

Infra-Red (IR) remote control sensor is located on the front and rear of the projector. The remote control must be held at an angle within 30 degrees perpendicular to the projector's IR remote control sensor to function correctly. The distance between the remote control and the sensor should not exceed 8 meters (~ 26 feet).

Make sure that there are no obstacles between the remote control and the IR sensor on the projector that might obstruct the infra-red beam.

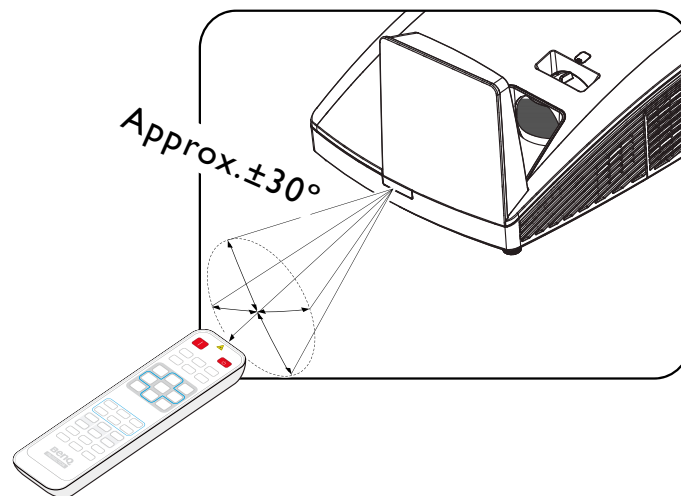

Positioning your projector

Using the Quick Install

The projector provides a hot key to set **Projector Position**, **Test Pattern**, **2D Keystone**, **Corner Fit** and **Digital Shrink & Shift** quickly.

Press **Quick Install** on the remote control and press ▲/▼ to select:

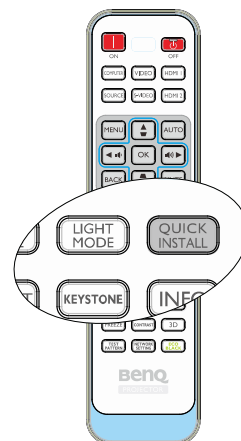
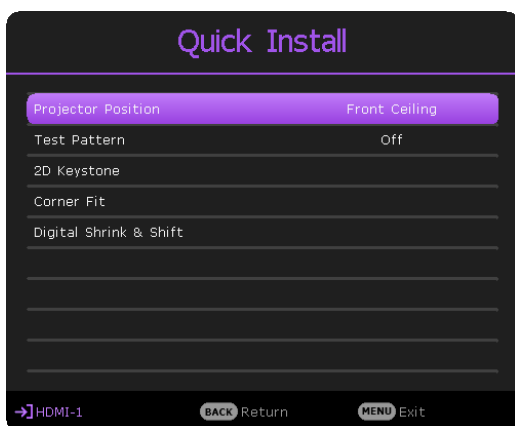

- Projector Position: See ["Positioning your projector"](#) on page 15.
- Test Pattern: See ["Test Pattern"](#) on page 46
- 2D Keystone: See ["Correcting 2D Keystone"](#) on page 27.
- Corner Fit: See ["Correcting Corner Fit"](#) on page 28.
- Digital Shrink & Shift: See ["Digital Shrink & Shift"](#) on page 47.

Choosing a location

Your projector is designed to be installed in one of four possible installation locations:

Front Wall

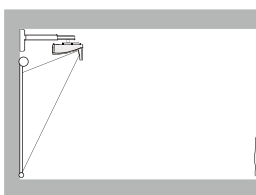

Rear Table

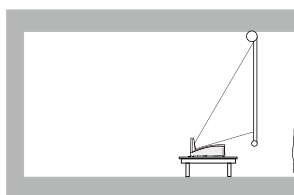

Front Table

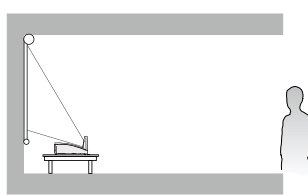

Rear Wall

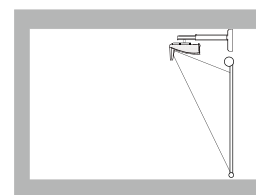

Use the test pattern

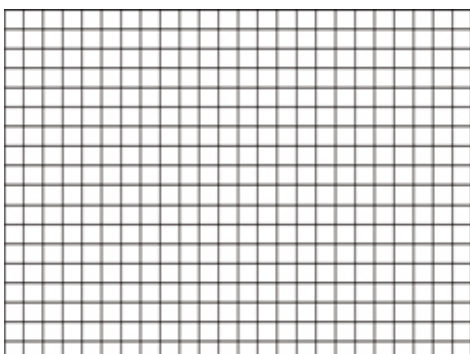

Correct the image

2D Keystone correction



Corner fit correction



Digital shrink and shift

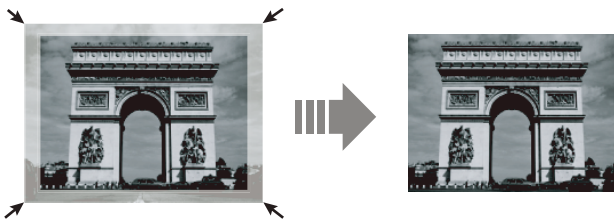

Set up your screen via **Quick Install** hotkey on remote, you can also go to the **Installation > Projector Position** menu after turning on the projector.

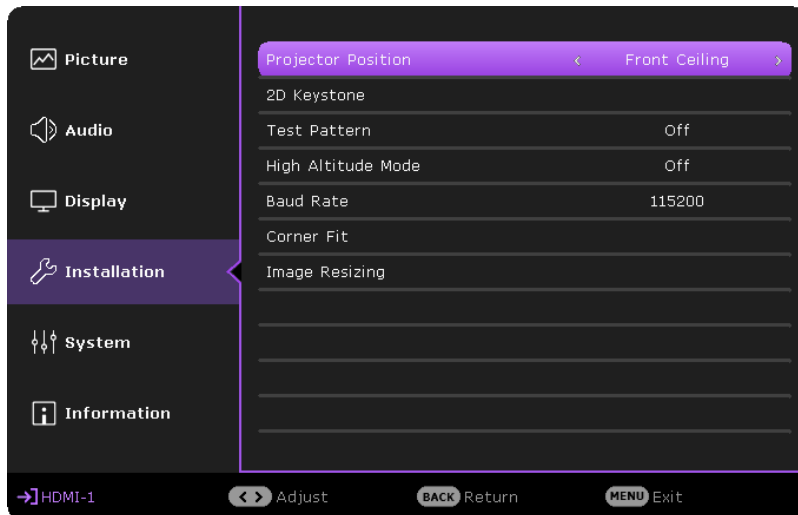

Your room layout or personal preference will dictate which installation location you select. Take into consideration the size and position of your screen, the location of a suitable power outlet, as well as the location and distance between the projector and the rest of your equipment.

Obtaining a preferred projected image size

Projection dimensions

Refer to "Dimensions" on page 21 for the center of lens dimensions of this projector before calculating the appropriate position.



To install the PointWrite Touch module, download the file "installation guide for PointWrite Touch module" from the BenQ website.

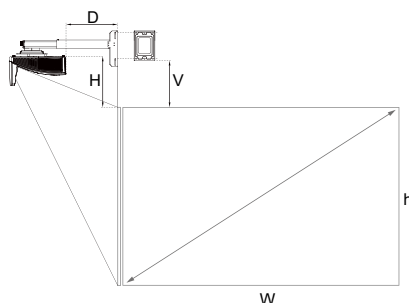

• LW855UST

The screen aspect ratio is 16:10 and the projected picture is 16:10.

WXGA											
Screen Size (Diagonal)		Screen Width (W)		Screen Height (h)		Projection Distance (D)		Offset (H)		Scale Parameter	Distance between Wall plate & projection screen (V)
Inch	mm	Inch	mm	Inch	mm	Inch	mm	Inch	mm	mm	
80	2032	68	1723	42	1077	11.23	285.4	11.85	300.9	513	277.1
85	2159	72	1831	45	1144	12.72	323.1	12.43	315.7	550	292.0
87	2210	74	1874	46	1171	13.31	338.1	12.66	321.7	565	297.9
90	2286	76	1939	48	1212	14.20	360.8	13.01	330.5	588	306.8
92	2337	78	1982	49	1239	14.80	375.8	13.25	336.5	603	312.7
95	2413	81	2046	50	1279	15.69	398.4	13.60	345.4	626	321.6
97	2464	82	2089	51	1306	16.28	413.5	13.83	351.3	641	327.5
100	2540	85	2154	53	1346	17.17	436.1	14.18	360.2	663	336.4

• LH856UST

The screen aspect ratio is 16:9 and the projected picture is 16:9.

1080P											
Screen Size (Diagonal)		Screen Width (W)		Screen Height (h)		Projection Distance (D)		Offset (H)		Scale Parameter	Distance between Wall plate & projection screen (V)
Inch	mm	Inch	mm	Inch	mm	Inch	mm	Inch	mm	mm	
81.2	2062	71	1798	40	1011	11.06	280.9	12.31	312.7	508	289.0
85	2159	74	1882	42	1058	12.16	308.9	12.77	324.4	536	300.6
88.9	2258	77	1968	44	1107	13.29	337.6	13.24	336.3	565	312.5
90	2286	78	1992	44	1121	13.61	345.7	13.37	339.7	573	315.9
92	2337	80	2037	45	1146	14.19	360.5	13.62	345.8	588	322.0
97	2464	85	2147	48	1208	15.64	397.4	14.22	361.1	625	337.4
100	2540	87	2214	49	1245	16.51	419.5	14.58	370.3	647	346.6
103.3	2624	90	2287	51	1286	17.47	443.8	14.98	380.4	671	356.7



There is 5% tolerance among these numbers due to optical component variations. BenQ recommends that if you intend to permanently install the projector, you should physically test the projection size and distance using the actual projector before you permanently install it, so as to make allowance for this projector's optical characteristics. This will help you determine the exact mounting position so that it best suits your installation location..



It is recommended to adjust focus 15 minutes after powering on due to the slight shifting of the lens from temperature changing.

Limited lens shift specification (No available in LH856UST)

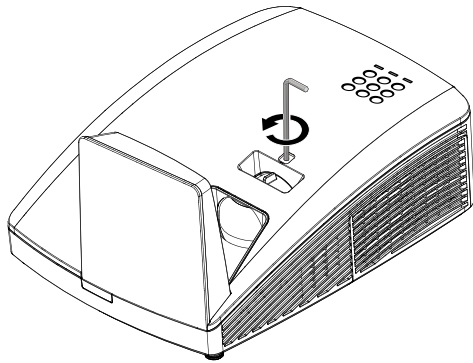
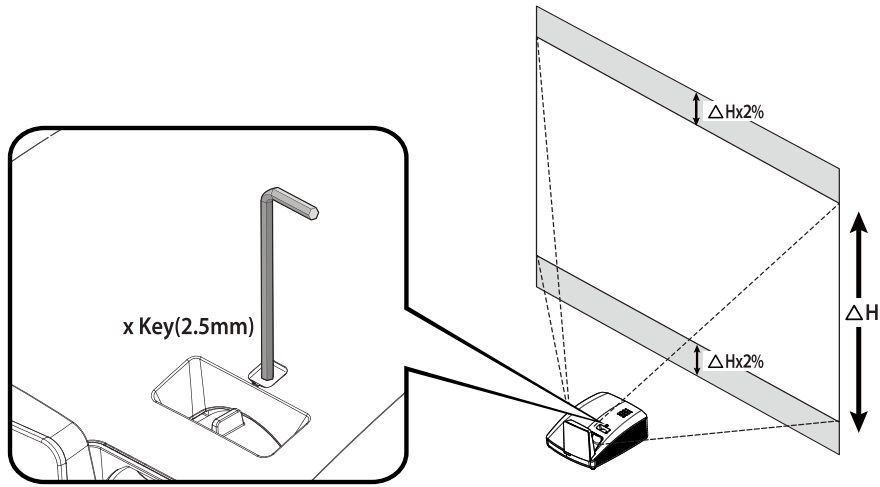

To shift up the projection image, twist the adjuster counter clockwise.

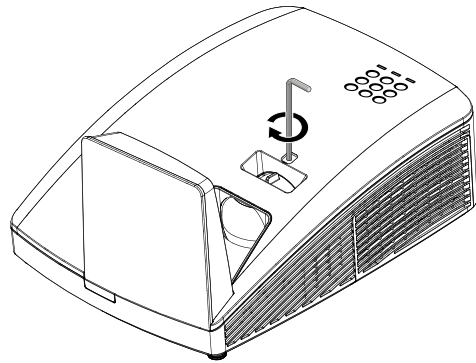

To shift down the projection image, twist the adjuster clockwise.

Mounting the projector

If you intend to mount your projector, we strongly recommend that you use a proper fitting BenQ projector mounting kit and that you ensure it is securely and safely installed.

If you use a non-BenQ brand projector mounting kit, there is a safety risk that the projector may fall down due to an improper attachment through the use of the wrong gauge or length screws.

Before mounting the projector

- Use BenQ Projector Wall Mounting Kit come with the package. Please refer to the User manual in the box of wall mount kit for installation details.
- BenQ recommends that you also purchase a separate Kensington lock compatible security cable and attach it securely to both the Kensington lock slot on the projector and the base of the mounting bracket. This will perform the secondary role of restraining the projector should its attachment to the mounting bracket become loose.
- Ask your dealer to install the projector for you. Installing the projector on your own may cause it to fall and result in injury.
- Take necessary procedures to prevent the projector from falling off such as during an earthquake.
- The warranty doesn't cover any product damage caused by mounting the projector with a non-BenQ brand projector mounting kit.
- Consider the surrounding temperature where the projector is ceiling/wall mounted. If a heater is used, the temperature around the ceiling may be higher than expected.
- Read the user manual for the mounting kit about the range of torque. Tightening with torque exceeding the recommended range may cause damage to the projector and subsequently falling off.
- Make sure the power outlet is at an accessible height so that you can easily shut down the projector.

Install the projector on the projector wall mount

- I. Slide the projector into the wall mount.

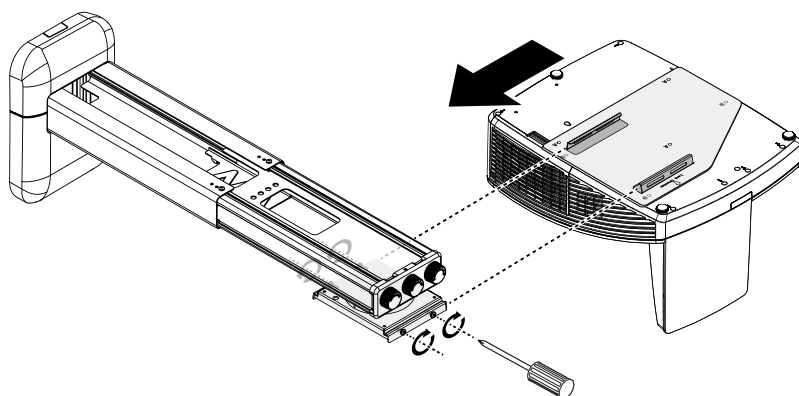

2. Adjust the Vertical Tilt/Horizontal Roll/Horizontal Rotation to adjust screen alignment and image position.

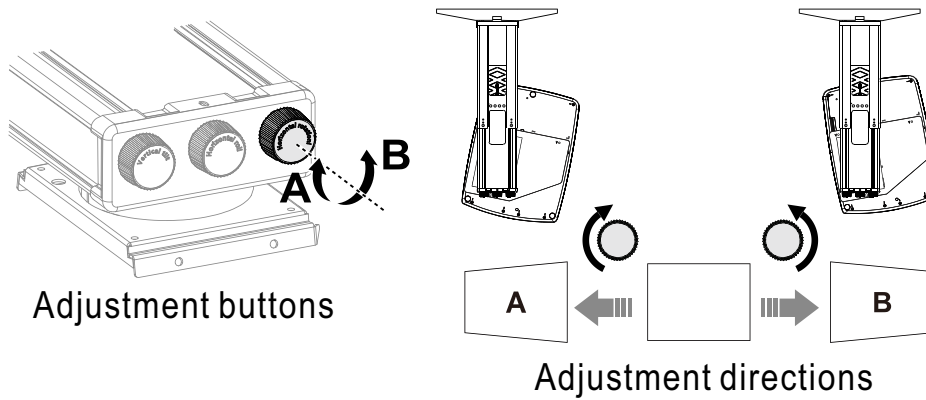
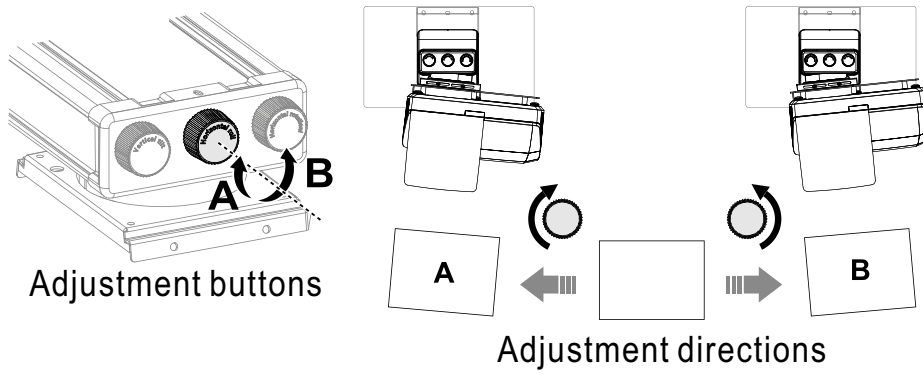
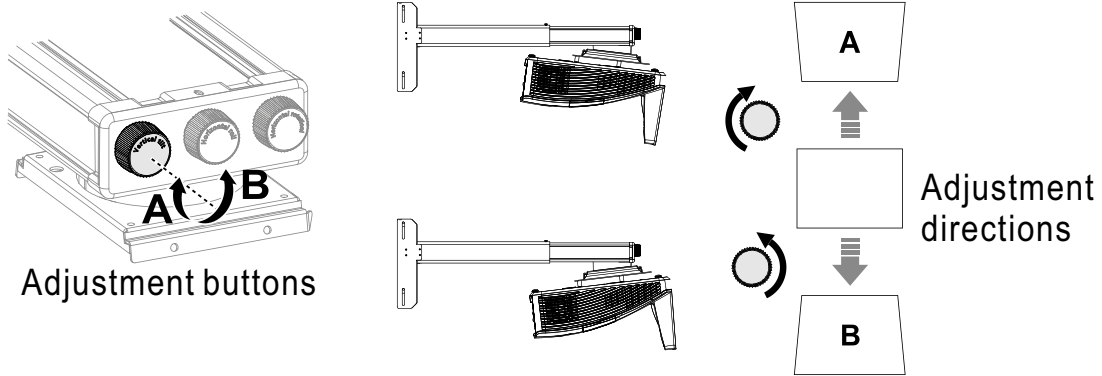

3. Adjust the Forward/Backward Slide to reduce/enlarge the image.

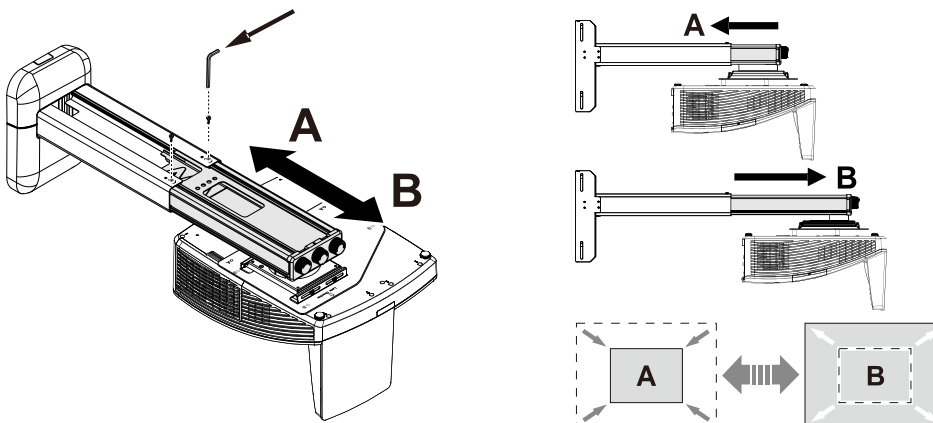

Dimensions

317.2mm (W) x 208.0 (H) x 376.4 (D)

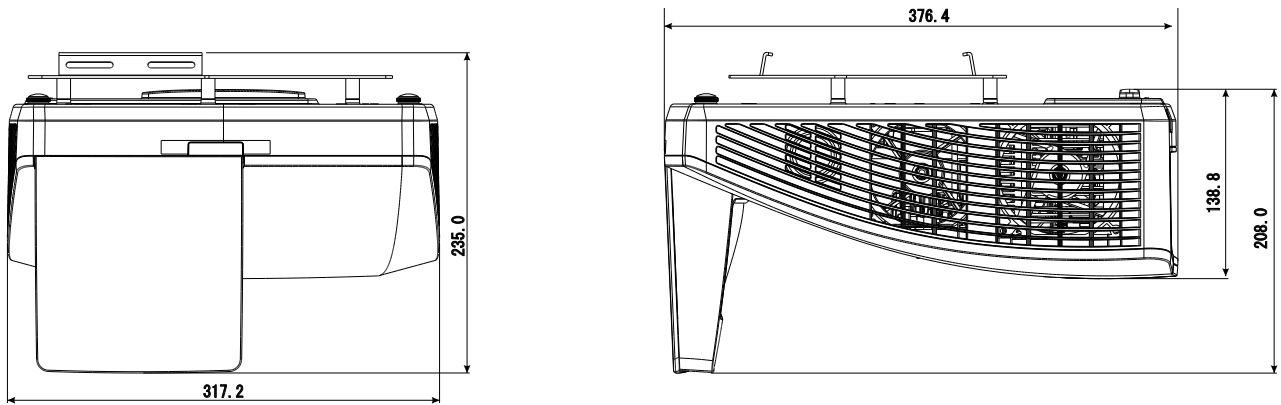

Unit: mm

Wall Mount Installation

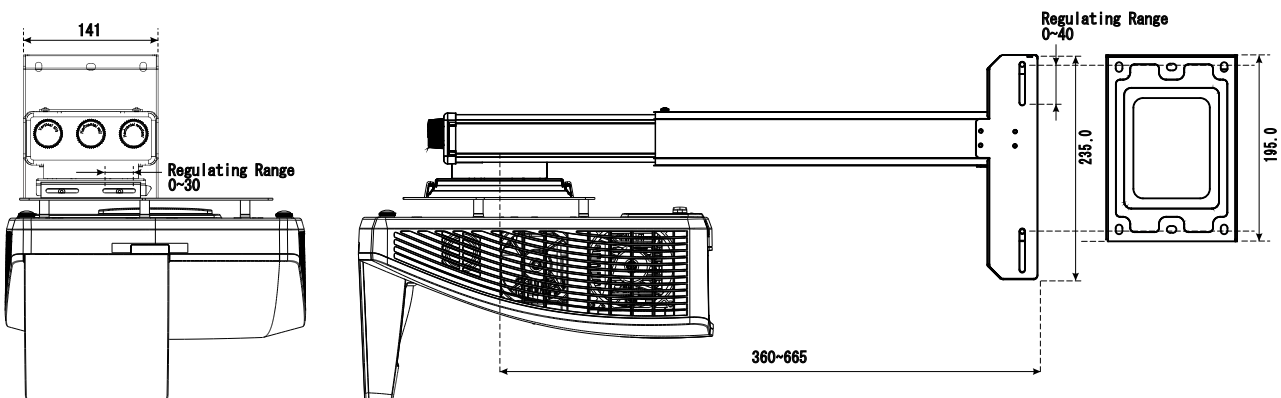
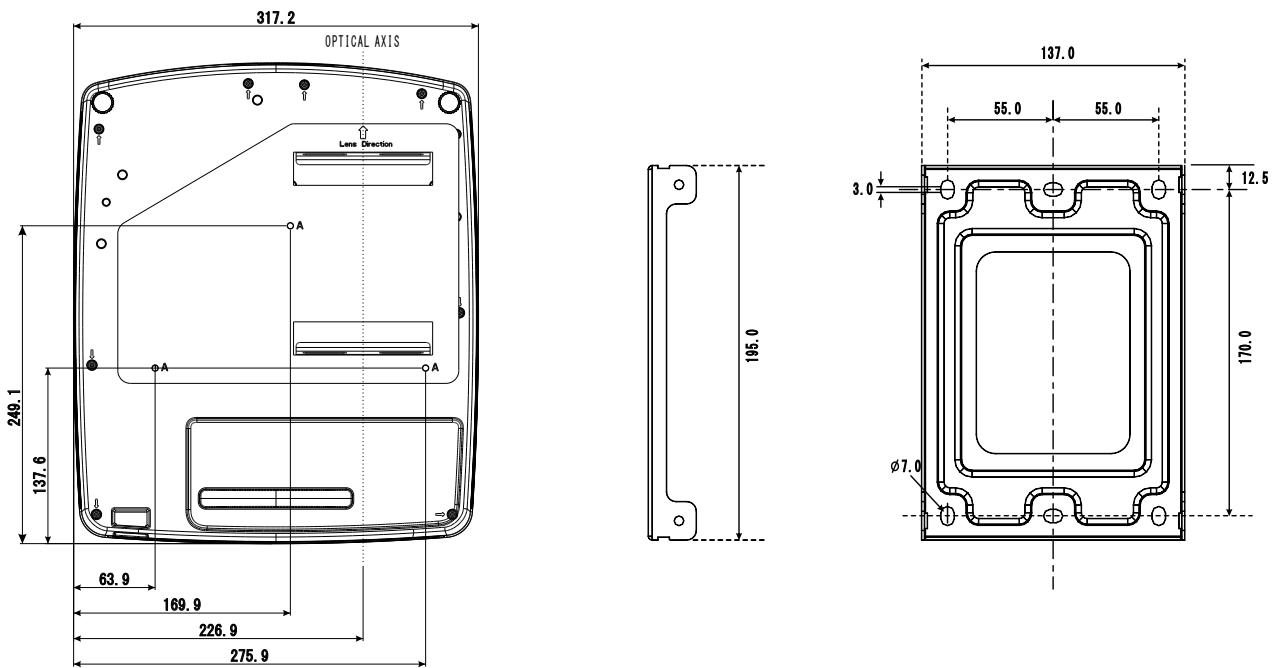

Connection

When connecting a signal source to the projector, be sure to:

1. Turn all equipment off before making any connections.
2. Use the correct signal cables for each source.
3. Ensure the cables are firmly inserted.

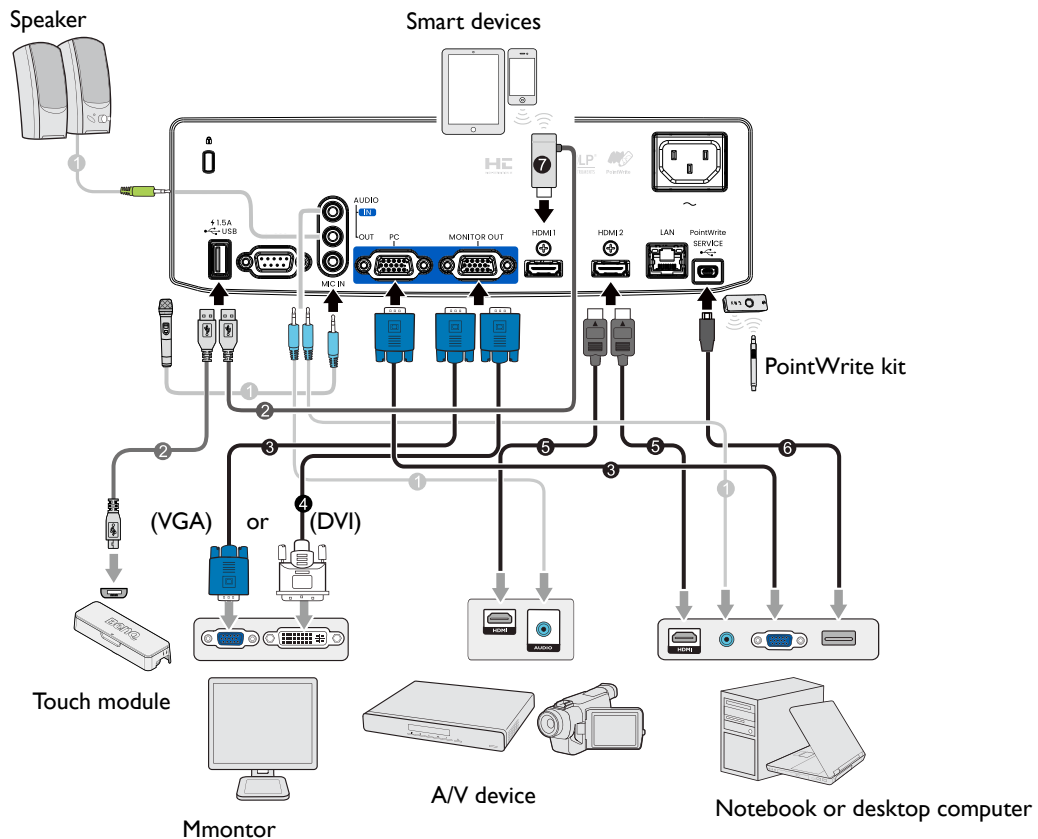

1. Audio cable
2. USB cable (A to micro B type): Connect to PointWrite Touch module or connect to the HDMI dongle for power supply
3. VGA cable
4. VGA to DVI-A cable
5. HDMI cable
6. USB cable
7. HDMI dongle (QCast Mirror, etc.)



- In the connections above, some cables may not be included with the projector (see "[Shipping contents](#)" on page 10). They are commercially available from electronics stores.
- The connection illustrations are for reference only. The rear connecting jacks available on the projector vary with each projector model.
- Many notebooks do not turn on their external video ports when connected to a projector. Usually a key combo like FN + function key with a monitor symbol turns the external display on/off. Press FN and the labeled function key simultaneously. Refer to your notebook's documentation to find your notebook's key combination.
- If the selected video image is not displayed after the projector is turned on and the correct video source has been selected, check that the video source device is turned on and operating correctly. Also check that the signal cables have been connected correctly.

Connecting video source devices

You need only connect the projector to a video source device using just one of the connecting methods, however each provides a different level of video quality. The method you choose will most likely depend upon the availability of matching terminals on both the projector and the video source device as described below:

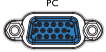
Terminal		Picture quality
HDMI		Best
Component Video (through RGB input)		Better

Connecting audio

The projector has built-in mono speaker(s) which are designed to provide basic audio functionality accompanying data presentations for business purposes only. They are not designed for, nor intended for stereo audio reproduction use as might be expected in home theater or home cinema applications. Any stereo audio input (if provided), is mixed into a common mono audio output through the projector speaker(s).

The built-in speaker(s) will be muted when the **AUDIO OUT** jack is connected.



- The projector is only capable of playing mixed mono audio, even if a stereo audio input is connected.
- If the selected video image is not displayed after the projector is turned on and the correct video source has been selected, check that the video source device is turned on and operating correctly. Also check that the signal cables have been connected correctly.

Connecting smart devices

The projector can project the content directly from a smart device by using a wireless dongle.

HDMI wireless dongle (e.g. BenQ QCastMirror)

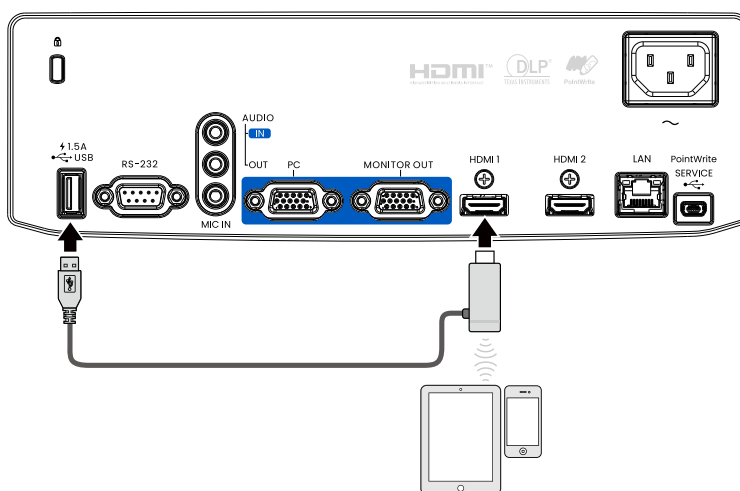

- Connect the dongle to HDMI 1 or HDMI 2 and USB TYPE-A ports on the projector and switch the input signal to HDMI 1 or HDMI 2.

Playing sound through the projector

You can make use of the projector speaker in your presentations, and also connect separate amplified speakers to the AUDIO OUT socket of the projector.

If you have a separate sound system, you will most likely want to connect the audio output of your Video source device to that sound system, instead of to the audio projector.

Once connected, the audio can be controlled by the projector On-Screen Display (OSD) menus.

The table below describes the connection methods for different devices, and where the sound is from.

Device	Computer/PC	HDMI
Audio input port	AUDIO IN (mini jack)	HDMI
The projector can play the sound from...	AUDIO IN (mini jack)	HDMI
Audio output port	AUDIO OUT	AUDIO OUT

The selected input signal determines which sound will be played by the projector speaker, and which sound will be output from the projector when AUDIO OUT is connected. If you select the COMPUTER/PC signal, the projector can play the sound received from AUDIO IN mini jack.

Operations

Starting up the projector

1. Plug the power cord into the projector and into a wall socket. Turn on the wall socket switch (where fitted). Check that the **POWER indicator light** on the projector lights orange after power has been applied.
2. Press **POWER** button on the projector or  on the remote control to start the projector. The **POWER indicator** flashes green and stays green when the projector is on.

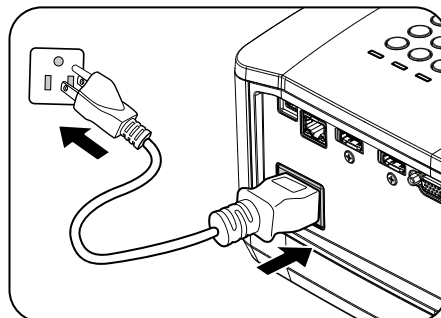

The start up procedure takes about 30 seconds. In the later stage of start up, a startup logo is projected.

(If necessary) Rotate the focus ring to adjust the image clearness.

3. If the projector is activated for the first time, select your OSD language following the on-screen instructions.
4. If you are prompted for a password, press the arrow keys to enter a 6-digit password. See "[Utilizing the password function](#)" on page 30.
5. Switch all of the connected equipment on.
6. The projector will search for input signals. The current input signal being scanned appears. If the projector does not detect a valid signal, the message "**No Signal**" will continue displaying until an input signal is found.



You can also press **SOURCE** to select your desired input signal. See "[Switching input signal](#)" on page 31.



- Please use the original accessories (e.g. power cord) to avoid possible dangers such as electric shock and fire.



- The Setup Wizard screenshots are for reference only and may differ from the actual design.
- If the frequency/resolution of the input signal exceeds the projector's operating range, you will see the message "Out of Range" displayed on the background screen. Please change to an input signal which is compatible with the projector's resolution or set the input signal to a lower setting. See "[Timing table](#)" on page 54.
- If no signal is detected for 3 minutes, the projector automatically enters saving mode.

Adjusting the projected image

Adjusting the projection angle

The projector is equipped with 2 adjuster feet. These adjusters change the image height and projection angle. To adjust the projector:

Screw adjuster foot to fine tune the horizontal angle.

To retract the foot, hold up the projector then slowly lower the projector. Screw the adjuster foot in a reverse direction.

If the projector is not placed on a flat surface or the screen and the projector are not perpendicular to each other, the projected image becomes trapezoidal. To correct this situation, see "[Correcting 2D Keystone](#)" on page 27 for details.

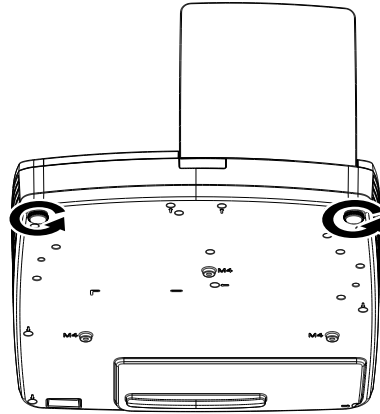

- Do not look into the lens while the projector is on. The strong light from the light may cause damage to your eyes.
- Be careful when you press the adjuster button as it is close to the exhaust vent where hot air comes from.

Auto-adjusting the image

In some cases, you may need to optimize the picture quality. To do this, press AUTO on the projector or remote control. Within 3 seconds, the built-in Intelligent Auto Adjustment function will re-adjust the values of Frequency and Clock to provide the best picture quality.

The current source information will be displayed in the upper left corner of the screen for 3 seconds.



- The screen will be blank while AUTO is functioning.
- This function is only available when PC signal (analog RGB) is selected.

Fine-tuning the image size and clarity

Sharpen the image by rotating the FOCUS ring.

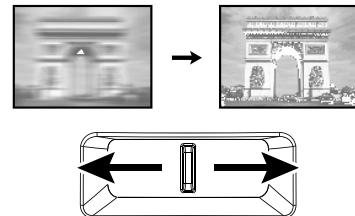

Correcting 2D Keystone

2D Keystone function enables a wider projector installation area compared to conventional projectors with limited positioning in front of the screen.

To correct this, you will need to manually correct it following one of these steps.

- Using the projector or remote control



Press / on the projector or remote control to display the 2D Keystone page. Press / to adjust vertical values from -15 to 15. Press / to adjust horizontal values from -15 to 15.

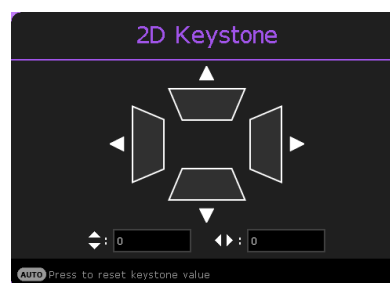

- Using the OSD menu

- Press **MENU** and then press / until the **Installation** menu is highlighted and press .
- Press / to highlight **2D Keystone** and press **OK**. The **2D Keystone** page displays.
- Press /// to adjust the keystone values.

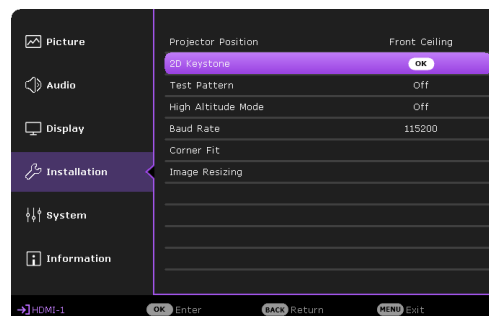

- Using the **QUICK INSTALL** key

- Press **QUICK INSTALL** on the remote control.
- Press / to highlight 2D Keystone and press **OK**. The **2D Keystone** page displays.
- Press /// to adjust the keystone values.

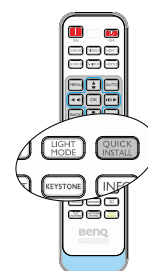

Correcting Corner Fit

Manually adjust four corners of the image by setting the horizontal and vertical values.

Using the OSD menu

1. Press **MENU** and then press **▲/▼** until the **Installation** menu is highlighted and press **▶**.
2. Press **▲/▼** to highlight **Corner Fit** and press **OK**. The **Corner Fit** page displays.
3. Press **▲/▼/◀/▶** to select one of the four corners and press **OK**.
4. Press **◀/▶** to adjust vertical values from 0 to 60.
5. Press **▲/▼** to adjust horizontal values from 0 to 60.

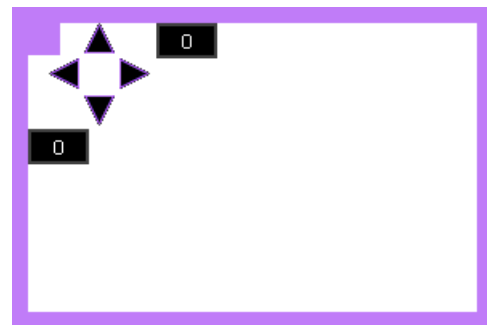
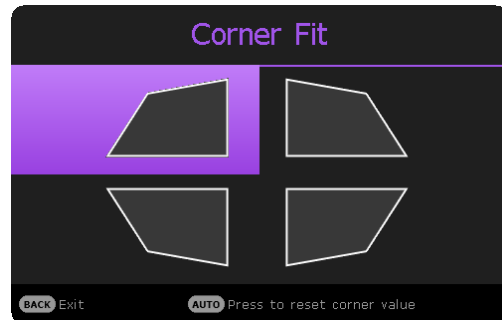
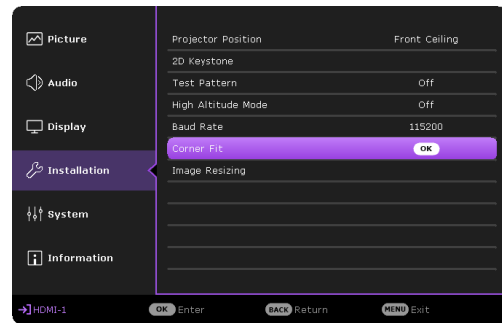

Corner Fit and 2D Keystone Adjustment Notice

The corner fit function is closely related to the 2D keystone function as both make adjustments to correct picture distortion. Therefore, when correcting picture distortion, both corner fit and 2D keystone functions should be used in conjunction to achieve the best picture shape.

To achieve the best picture shape:

- When installing the projector, align the projector to the screen so they are as perpendicular to each other as possible in order to minimize picture distortion.
- When making corner fit adjustments, if the desired effect cannot be achieved, adjust the 2D keystone value and try again.
- When making 2D keystone adjustments, if the desired effect cannot be achieved, adjust the corner fit value and try again.

Using the menus

The projector is equipped with 2 types of On-Screen Display (OSD) menus for making various adjustments and settings.

- **Basic** OSD menu: provides primary menu functions. (See "[Basic menu](#)" on page 38)
- **Advanced** OSD menu: provides full menu functions. (See "[Advanced menu](#)" on page 40)

To access the OSD menu, press **MENU** on the projector or remote control.

- Use the arrow keys (**▲/▼/◀/▶**) on the projector or remote control to move through the menu items.
- Use **OK** on the projector or remote control to confirm the selected menu item.

The first time you use the projector (after finishing the initial setup), Basic OSD menu displays.



The OSD screenshots below are for reference only, and may differ from the actual design.

Below is the overview of the **Basic** OSD menu.

	1	Menu Type	4	Press OK to enter the menu.
	2	Main menu	5	Status
	3	Current input signal	6	Press MENU to go to the previous page or to exit.

If you intend to switch from the **Basic** OSD menu to the **Advanced** OSD menu, follow the instructions below:

1. Go to **Basic Menu > Menu Type**.
2. Press **OK** and press **▲/▼** to select **Advanced**. Next time when you turn on the projector, you may access the **Advanced** OSD menu by pressing **MENU**.

Below is the overview of the **Advanced** OSD menu.

	1	Main menu & Main menu icon	5	Press BACK to go to the previous page.
	2	Sub-menu	6	Press MENU to go to the previous page or to exit.
	3	Current input signal	7	Status
	4	Press OK to enter the menu.		

Likewise, when you wish to switch from the **Advanced** OSD menu to the **Basic** OSD menu, follow the instructions below:

1. Go to **Advanced Menu - System > Menu Settings** and press **OK**.
2. Select **Menu Type** and **OK**.
3. Press **▲/▼** to select **Basic**. Next time when you turn on the projector, you may access the **Basic** OSD menu by pressing **MENU**.

Securing the projector

Using a security cable lock

The projector has to be installed in a safe place to prevent theft. Otherwise, purchase a lock, such as a Kensington lock, to secure the projector. You can locate a Kensington lock slot on the left side of the projector. See "[Kensington anti-theft lock slot](#)" on [page 11](#) for details.

A Kensington security cable lock is usually a combination of key(s) and a lock. Refer to the lock's documentation for finding out how to use it.

Utilizing the password function

Setting a password

1. Go to **Advanced Menu - System > Security Settings**. Press **OK**. The **Security Settings** page appears.
2. Highlight **Change Password** and press **OK**.
3. The four arrow keys (**▲/▶/▼/◀**) respectively represent 4 digits (1, 2, 3, 4). According to the password you desire to set, press the arrow keys to enter six digits for the password.
4. Confirm the new password by re-entering the new password.
Once the password is set, the OSD menu returns to the **Security Settings** page.
5. To activate the **Power On Lock** function, press **▲/▼** to highlight **Power On Lock** and press **OK**. Press **◀/▶** to select **On**. Input the password again.

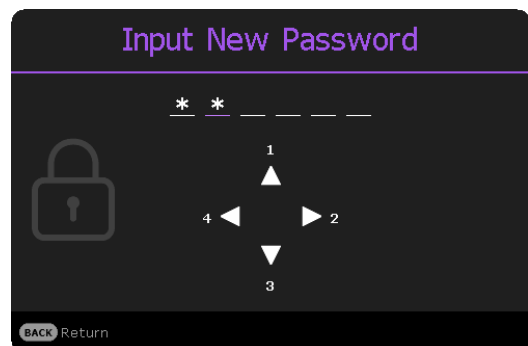

- The digits being input will display as asterisks on-screen. Make a note of your selected password and keep it in a safe place in advance or right after the password is entered so that it is available to you should you ever forget it.
- Once a password has been set and the power on lock is activated, the projector cannot be used unless the correct password is entered every time the projector is started.

If you forget the password

If you enter the wrong password, the password error message will appear, and the **Input Current Password** message follows. If you absolutely do not remember the password, you can use the password recall procedure. See "[Entering the password recall procedure](#)" on [page 31](#).

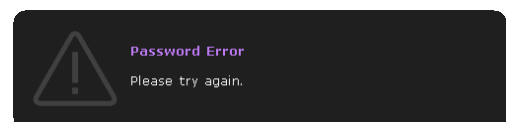

If you enter an incorrect password 5 times in succession, the projector will automatically shut down in a short time.

Entering the password recall procedure

1. Press and hold **OK** for 3 seconds. The projector will display a coded number on the screen.
2. Write down the number and turn off your projector.
3. Seek help from the local **BenQ** service center to decode the number. You may be required to provide proof of purchase documentation to verify that you are an authorized user of the projector.

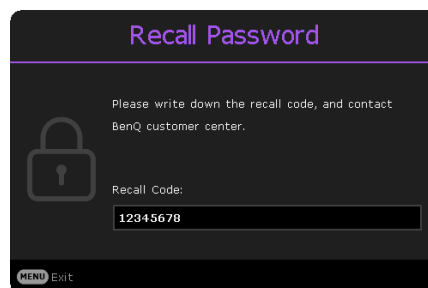

Changing the password

1. Go to **Advanced Menu - System > Security Settings > Change Password**.
2. Press **OK**. The message **"Input Current Password"** appears.
3. Enter the old password.
 - If the password is correct, another message **"Input New Password"** appears.
 - If the password is incorrect, the password error message will appear, and the message **"Input Current Password"** appears for your retry. You can press **BACK** to cancel the change or try another password.
4. Enter a new password.
5. Confirm the new password by re-entering the new password.

Disabling the password function

To disable password protection, go to **Advanced Menu - System > Security Settings > Power On Lock** and press **OK**. Press **◀▶** to select **Off**. The message **"Input Current Password"** appears. Enter the current password.

1. If the password is correct, the OSD menu returns to the **Security Settings** page. You will not have to enter the password next time turning on the projector.
2. If the password is incorrect, the password error message will appear, and the message **"Input Current Password"** appears for your retry. You can press **BACK** to cancel the change or try another password.



Though the password function is disabled, you need to keep the old password in hand should you ever need to re-activate the password function by entering the old password.

Switching input signal

The projector can be connected to multiple devices at the same time. However, it can only display one full screen at a time. When starting up, the projector automatically searches for the available signals.

Be sure the **Advanced Menu - Display > Auto Source Search** menu is **On** if you want the projector to automatically search for the signals.



To select the source:

1. Press **SOURCE**. A source selection bar appears.
2. Press **▲▼** until your desired signal is selected and press **OK**.

Once detected, the selected source information will appear at the corner of the screen for seconds. If there is multiple equipment connected to the projector, repeat steps 1-2 to search for another signal.



- The brightness level of the projected image will change accordingly when you switch between different input signals.
- For best display picture results, you should select and use an input signal which outputs at the projector's native resolution. Any other resolutions will be scaled by the projector depending upon the "aspect ratio" setting, which may cause some image distortion or loss of picture clarity. See "[Aspect Ratio](#)" on [page 38](#) for details.

Installing PointWrite module on projector to use interaction function

You can install a PointWrite module (PW30U, an optional accessory sold independently) on the projector to start the interactive function.

Camera installation on projector

Make sure the PointWrite camera is installed properly before you active interactive function.

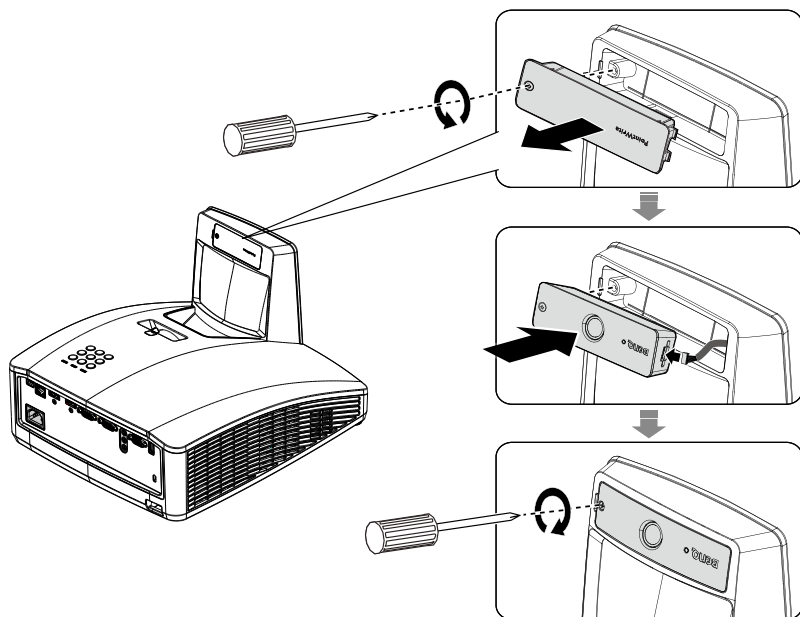

Use the USB cable to connect the projector to PC. Plug the USB mini-B end into the projector and plug the USB-A end into PC.

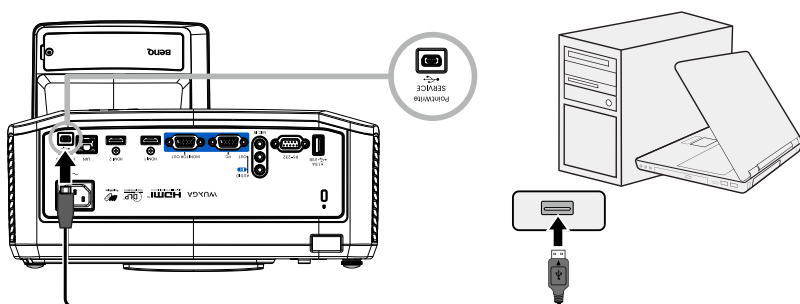

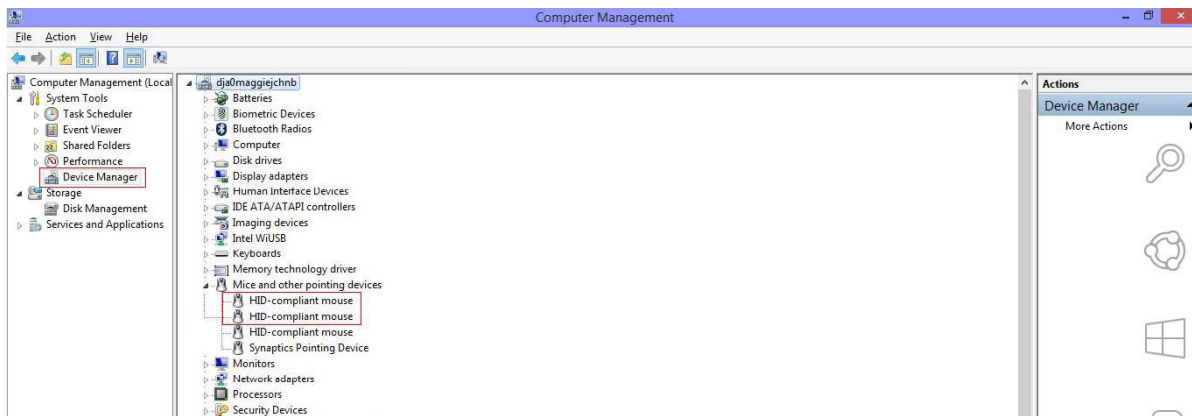

Check Device Manager from your computer to make sure that PointWrite device is recognized by your computer.



When finishing the PointWrite module installation, please refer to the PW30U user manual for further instruction.

Shutting down the projector

1. Press **POWER** on the projector or  on the remote control and a confirmation message will appear prompting you. If you don't respond in a few seconds, the message will disappear.
2. Press **POWER** or  a second time. The power indicator flashes orange, the projector shuts down, and the fans will continue to run for approximately 3 seconds to quick cool down the projector.
3. Once the cooling process finishes, the power indicator becomes a steady orange and fans stop. Disconnect the power cord from the power outlet.

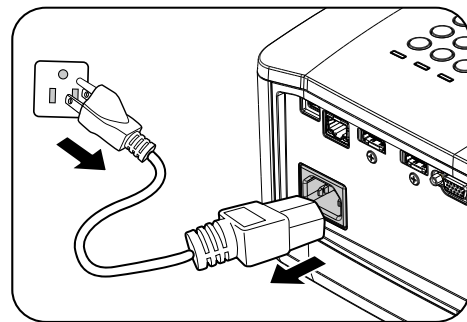

Menu operation

Please note that the on-screen display (OSD) menus vary according to the signal type selected and the projector model you are using.

The menu items are available when the projector detects at least one valid signal. If there is no equipment connected to the projector or no signal detected, limited menu items are accessible.

Menu System

Basic menu

Main menu	Options
Brightness	0~50~100
Aspect Ratio	Auto/4:3/16:9/16:10
Picture Mode	Bright/Presentation/Spreadsheet/sRGB/Video/ User 1/User 2/(3D)/(HDR 10)/(HLG)
Volume	0~5~10
Light Source Mode	Normal/ECO/Dynamic Dimming/Custom
2D Keystone	H: -15~0~15 V: -15~0~15
Information	Native Resolution
	Detected Resolution
	Source
	Picture Mode
	Light Source Mode
	3D Format
	Color System
	Light Usage Time
	Firmware Version
	Service Code
Menu Type	Basic/Advanced

Advanced menu

Main menu	Submenu	Options	
Picture	Picture Mode	Bright/Presentation/Spreadsheet/sRGB/Video/User 1/User 2/(3D)/(HDR 10)/(HLG)	
	Reference Mode	Bright/Presentation/Spreadsheet/sRGB/Video/(3D)/(HDR10)/(HLG)	
	Brightness	0~50~100	
	Contrast	0~50~100	
	Color	0~50~100	
	Tint	0~50~100	
	Sharpness	0~15~31	
	Brilliant Color	0~10	
		Gamma Selection	1.8/2.0/2.1/2.2/2.3/2.4/2.5/2.6/BenQ
			Color Temperature (Normal/Cool/Warm)
			R Gain (0~200)
		Color Temperature Tuning	G Gain (0~200)
			B Gain (0~200)
			R Offset (0~511)
			G Offset (0~511)
			B Offset (0~511)
			R (Hue/Saturation/Gain)
			G (Hue/Saturation/Gain)
			B (Hue/Saturation/Gain)
		Advanced Color Settings	C (Hue/Saturation/Gain)
		M (Hue/Saturation/Gain)	
		Y (Hue/Saturation/Gain)	
		W (R Gain/B Gain/G Gain)	
		Reset	
	Light Source Mode	Normal/ECO/Dynamic Dimming/Custom	
	Custom Brightness	40~100	
	HDR Brightness	-2/-1/0/1/2	
	Noise Reduction	0~31	
	Reset Picture	Reset/Cancel	
Audio	Mute	Off / On	
	Volume	0~5~10	
	Microphone Switch	Off/On	
	Microphone Volume	0~5~10	
	Power On/Off Ring Tone	Off/On	
	Reset Audio	Reset/Cancel	

Main menu	Submenu	Options	
	Aspect Ratio	Auto/4:3/16:9/16:10	
	Auto Source Search	On/Off	
	PC & Component YPbPr Tuning	Phase (0~AUTO~31) H. Size (-15~0~15) Position (H: -5~0~5/V: -5~0~5)	
	Auto Sync	On / Off	
Display	3D	3D Mode	Auto/Top Bottom/Frame Sequential/ Frame Packing/Side-By-Side/Off
		3D Sync Invert	Disable/Invert
		Save 3D Settings	3D Settings 1/3D Settings 2/ 3D Settings 3
		Apply 3D Settings	3D Settings 1/3D Settings 2/ 3D Settings 3/Off
	HDMI Settings	HDMI Format	Auto/Limited/Full
		HDMI Equalizer	HDMI-1/HDMI-2
		HDMI EDID	HDMI-1/HDMI-2
		Fast Mode	Off/On
		Reset Display	Reset/Cancel
		Projector Position	Front/Front Ceiling/Rear/Rear Ceiling
	2D Keystone	H: -15~0~15 V: -15~0~15	
	Test Pattern	Off/On	
	High Altitude Mode	Off/On	
	Baud Rate	9600/14400/19200/38400/57600/115200	
Installation	Corner Fit	Top Left	H: 0~60 V: 0~60
		Top Right	H: 0~60 V: 0~60
		Bottom Left	H: 0~60 V: 0~60
		Bottom Right	H: 0~60 V: 0~60
		Digital Zoom	PC: 1.0X~2.0X Video: 1.0X~1.8X
		Digital Shrink & Shift	0.8x~1.0x
	Image Resizing		Modes of adjustment (One Side/ Opposite Sides/All 4 sides) Top (0~100) Bottom (0~100) Left (0~100) Right (0~100)
		Blanking	Reset all Blanking settings (Reset/Cancel)

Main menu	Submenu	Options	
	Language	English/Français/Deutsch/Italiano/Español/ Русский/繁體中文/简体中文/日本語/한국어/ Svenska / Nederlands/Türkçe/Čeština/ Português/ไทย/PolSKI/Magyar/Hrvatski/ Română/Norsk/Dansk/Български/ Suomi/Bhs Ind/Ελληνικά/العربية/हिंदी/ Tiếng Việt / فارسی	
	Background Settings	Background Color Black/Blue/Purple Splash Screen BenQ/Black/Blue	
	Menu Settings	Menu Type Basic/Advanced Menu Display Time 5 sec/10 sec/20 sec/30 sec/Always	
	Light Source Information	Light Usage Time Normal Mode ECO Mode Dynamic Dimming Mode Custom Mode	
System	Standby Settings	Standby Mode ECO/Network/Normal Auto Disable	
		Network Standby Mode Never/20 min/1 hr/3 hr/6 hr	
		Audio Pass Through Off/Audio In/Microphone/HDMI-1/ HDMI-2	
	Operation Settings	Reminder Message On/Off	
		Power On/Off Settings Direct Power On Signal Power On Auto Power Off	
		Panel Key Lock Off/On	
	Security Settings	Change Password	
		Power On Lock Off/On	
	Network Settings	Wired LAN	Status DHCP IP Address Subnet Mask Default Gateway DNS Server Apply
			AMX Device Discovery Off/On
MAC Address (Wired)			
Factory Default Reset/Cancel			
Reset System Reset/Cancel			

Main menu	Submenu	Options
Information	Native Resolution	
	Detected Resolution	
	Source	
	Picture Mode	
	Light Source Mode	
	3D Format	
	Color System	
	Light Usage Time	
	Firmware Version	
	Service Code	

Basic menu

Brightness	The higher the value, the brighter the image. Adjust this control so the black areas of the image appear just as black and that detail in the dark areas is visible.	
Aspect Ratio	There are several options to set the image's aspect ratio depending on your input signal source.	
	<ul style="list-style-type: none"> Auto: Scales an image proportionally to fit the projector's native resolution in its horizontal or vertical width. 	<p>(LW855UST) (LH856UST)</p>
	<ul style="list-style-type: none"> 4:3: Scales an image so that it is displayed in the center of the screen with a 4:3 aspect ratio 	<p>4:3 picture</p>
	<ul style="list-style-type: none"> 16:9: Scales an image so that it is displayed in the center of the screen with a 16:9 aspect ratio 	<p>16:9 picture</p>
	<ul style="list-style-type: none"> 16:10: Scales an image so that it is displayed in the center of the screen with a 16:10 aspect ratio 	<p>16:10 picture</p>



Picture Mode	<p>The projector is preset with several predefined picture modes so that you can choose one to suit your operating environment and input signal picture type.</p> <ul style="list-style-type: none"> • Bright: Maximizes the brightness of the projected image. This mode is suitable for environments where extra-high brightness is required, such as using the projector in well lit rooms. • Presentation: Is designed for presentations. The brightness is emphasized in this mode to match PC and notebook coloring. • Spreadsheet: Design for users who widely use excel and table to discuss financial numbers or quality numbers in the meeting. • sRGB: Maximizes the purity of RGB colors to provide true-to-life images regardless of brightness setting. It is most suitable for viewing photos taken with an sRGB compatible and properly calibrated camera, and for viewing PC graphic and drawing applications such as AutoCAD. • Video: This is suitable for displaying colorful video and pictures with well-balanced color saturation and high color brightness. • User 1/User 2: Recalls the settings customized based on the current available picture modes. See "Reference Mode" on page 41. • 3D: Is appropriate for playing 3D images and 3D video clips. • HDRI0:Hidden as default. • HLG:Hidden as default.
Volume	Adjusts the sound level.
Light Source Mode	<ul style="list-style-type: none"> • Normal: Provides 100% light source power • ECO: 80% light source power.(The power depends on platform) • Dynamic Dimming: Detect the video content to adjust power between 40%-100% to enhance contrast. • Custom: Adjust brightness value on the bar, adjust value: 40~100% Adjustable range from 40%-100% light source power *Custom Brightness adjust bar will only be enabled when Custom Mode selected.
2D Keystone	Adjusts the shape of the projected image to ensure straight lines on all four corners. See "Correcting 2D Keystone" on page 27 for details.

Information	<ul style="list-style-type: none"> • Native Resolution: Shows the native resolution of the projector. • Detected Resolution: Shows the native resolution of the input signal. • Source: Shows the current signal source. • Picture Mode: Shows the selected mode in the Picture menu. • Light Source Mode: Shows the selected mode in the Light Settings menu. • 3D Format: Shows the current 3D mode. • Color System: Shows input system format. • Light Usage Time: Shows the number of hours the light source has been used. • Firmware Version: Shows the firmware version of your projector. • Service Code: Shows the projector serial number.
Menu Type	Switches to the Advanced OSD menu. See "Using the menus" on page 29 .

Advanced menu

Picture

Picture Mode	<p>The projector is preset with several predefined picture modes so that you can choose one to suit your operating environment and input signal picture type.</p> <ul style="list-style-type: none"> • Bright: Maximizes the brightness of the projected image. This mode is suitable for environments where extra-high brightness is required, such as using the projector in well lit rooms. • Presentation: Is designed for presentations. The brightness is emphasized in this mode to match PC and notebook coloring. • Spreadsheet: Design for users who widely use excel and table to discuss financial numbers or quality numbers in the meeting. • sRGB: Maximizes the purity of RGB colors to provide true-to-life images regardless of brightness setting. It is most suitable for viewing photos taken with an sRGB compatible and properly calibrated camera, and for viewing PC graphic and drawing applications such as AutoCAD. • Video: This is suitable for displaying colorful video and pictures with well-balanced color saturation and high color brightness. • User 1/User 2: Recalls the settings customized based on the current available picture modes. See "Reference Mode" on page 41. • 3D: Is appropriate for playing 3D images and 3D video clips. • HDRI0:Hidden as default. • HLG:Hidden as default.
---------------------	--

Reference Mode	<p>There are 2 user-definable modes if the current available picture modes are not suitable for your need. You can use one of the picture modes (except the User 1/User 2) as a starting point and customize the settings.</p> <ol style="list-style-type: none"> 1. Go to Picture > Picture Mode. 2. Press ◀▶ to select User 1 or User 2. 3. Press ▼ to highlight Reference Mode, and press ◀▶ to select a picture mode that is closest to your need. 4. Press ▼ to select a menu item to be changed and adjust the value. The adjustments define the selected user mode.
Brightness	<p>The higher the value, the brighter the image. Adjust this control so the black areas of the image appear just as black and that detail in the dark areas is visible.</p>
Contrast	<p>The higher the value, the greater the contrast. Use this to set the peak white level after you have previously adjusted the Brightness setting to suit your selected input and viewing environment.</p>
Color	<p>Lower setting produces less saturated colors. If the setting is too high, colors on the image will be overpowering, which makes the image unrealistic.</p> <p> Only YUV color space is supported.</p>
Tint	<p>The higher the value, the more greenish the picture becomes. The lower the value, the more reddish the picture becomes.</p> <p> Only YUV color space is supported.</p>
Sharpness	<p>The higher the value, the sharper the picture becomes.</p>
Brilliant Color	<p>This feature utilizes a new color-processing algorithm and system level enhancements to enable higher brightness while providing truer, more vibrant colors in picture. It enables a greater than 50% brightness increase in mid-tone images, which are common in video and natural scenes, so the projector reproduces images in realistic and true colors. If you prefer images with that quality, select On.</p> <p>When Off is selected, the Color Temperature function is not available.</p>

Advanced Color Settings

Gamma Selection

To select a preferred gamma setting, which are defined by gamma tables.

Color Temperature Tuning

You can also set a preferred color temperature by adjusting the following options.

- **Color Temperature**

There are several preset color temperature settings available. The available settings may vary according to the signal type selected.

- Normal: Maintains normal colorings for white.
- Cool: Makes images appear bluish white.
- Warm: Makes images appear reddish white.
- **R Gain/G Gain/B Gain:** Adjusts the contrast levels of Red, Green, and Blue.
- **R Offset/G Offset/B Offset:** Adjusts the brightness levels of Red, Green, and Blue

Color Management

This function provides seven sets (RGBCMYW) of colors to be adjusted. When you select each color, you can independently adjust its range and saturation according to your preference.

- **Primary Color:** Selects a color from among **R** (Red), **G** (Green), **B** (Blue), **C** (Cyan), **M** (Magenta), **Y** (Yellow).or **W** (White).

- **Hue:** Increase in the range will include colors consisted of more proportions of its two adjacent colors. Please refer to the illustration for how the colors relate to each other.

For example, if you select Red and set its range at 0, only pure red in the projected picture will be selected. Increasing its range will include red close to yellow and red close to magenta.

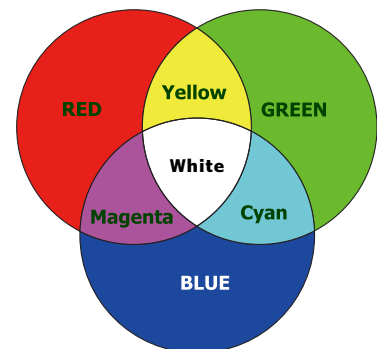

- **Saturation:** Adjusts the values to your preference. Every adjustment made will reflect to the image immediately. For example, if you select Red and set its value at 0, only the saturation of pure red will be affected.



Saturation is the amount of that color in a video picture. Lower settings produce less saturated colors; a setting of "0" removes that color from the image entirely. If the saturation is too high, that color will be overpowering and unrealistic.



- **Gain:** Adjusts the values to your preference. The contrast level of the primary color you select will be affected. Every adjustment made will reflect to the image immediately.



Advanced Color Settings	<ul style="list-style-type: none"> • Light Source Mode <ul style="list-style-type: none"> • Normal: Provides 100% light source power • ECO: 80% light source power.(The power depends on platform) • Dynamic Dimming: Detect the video content to adjust power between 40%-100% to enhance contrast. • Custom: Adjust brightness value on the bar, adjust value: 40~100% Adjustable range from 40%-100% light source power *Custom Brightness adjust bar will only be enabled when Custom Mode selected. • Custom Brightness: Adjust the light power manually. • HDR Brightness <ul style="list-style-type: none"> • To select a preferred HDR EOTF (HDR10 and HLG) setting via adjusting HDR EOTF curve, which are defined by HDR tables. • HDR10 and HLG will share the same description of settings but the values of EOTF will be divided in each mode. • Noise Reduction: To reduce electrical image noise. The higher the setting, the less the image noise.
Reset Picture	Returns all of the adjustments you've made for the Picture menu to the factory preset values.

Audio

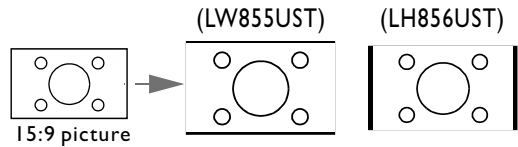
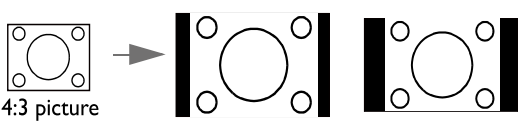
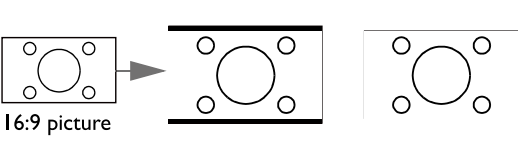
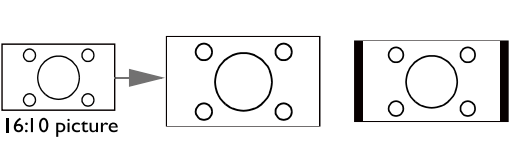
Mute	To enable or disable mute function.
Volume	Adjusts the sound level.
Microphone Switch	To enable or disable microphone Switch function.
Microphone Volume	Adjusts the microphone sound level.
Power On/Off Ring Tone	To enable or disable power on/off ring tone
Reset Audio	To reset audio mode settings to default.

Display

Aspect Ratio	<p>There are several options to set the image's aspect ratio depending on your input signal source.</p>	
	<ul style="list-style-type: none"> • Auto: Scales an image proportionally to fit the projector's native resolution in its horizontal or vertical width. 	 <p>15:9 picture</p>
	<ul style="list-style-type: none"> • 4:3: Scales an image so that it is displayed in the center of the screen with a 4:3 aspect ratio 	 <p>4:3 picture</p>
	<ul style="list-style-type: none"> • 16:9: Scales an image so that it is displayed in the center of the screen with a 16:9 aspect ratio 	 <p>16:9 picture</p>
	<ul style="list-style-type: none"> • 16:10: Scales an image so that it is displayed in the center of the screen with a 16:10 aspect ratio 	 <p>16:10 picture</p>
Auto Source Search	<p>Allows the projector to automatically search for a signal..</p>	
PC & Component YPbPr Tuning	<ul style="list-style-type: none"> • Phase: Adjusts the clock phase to reduce image distortion. This function is only available when a PC signal (analog RGB) or YPbPr signal is selected. 	
	<ul style="list-style-type: none"> • H. Size: Adjusts the horizontal width of the image. This function is only available when a PC signal (analog RGB) is selected. 	
	<ul style="list-style-type: none"> • Position: Displays the position adjustment page. To move the projected image, use the directional arrow keys. This function is only available when a PC signal (analog RGB) is selected. 	
Auto Sync	<ul style="list-style-type: none"> • On: Allows the projector to automatically determines the best picture timings for the displayed image when PC signal (analog RGB) is selected and AUTO is pressed. • Off: The projector will not respond when AUTO is pressed. 	

<p>3D</p>	<p>This projector features a 3D function which enables you to enjoy the 3D movies, videos, and sporting events in a more realistic way by presenting the depth of the images. You need to wear a pair of 3D glasses to view the 3D images.</p> <ul style="list-style-type: none"> • 3D Mode: The default setting is Off. If you want the projector to automatically choose an appropriate 3D format when detecting 3D contents, select Auto. If the projector cannot recognize the 3D format, press ▲/▼ to choose a 3D mode from among Top Bottom, Frame Sequential, Frame Packing and Side by Side. <p> When 3D function is activated:</p> <ul style="list-style-type: none"> • The brightness level of the projected image will decrease. • The following settings cannot be adjusted: Picture Mode, Reference Mode. • The Keystone can only be adjusted within limited degrees. <ul style="list-style-type: none"> • 3D Sync Invert: When you discover the inversion of the image depth, enable this function to correct the problem. • Save 3D Settings: When you have successfully displayed the 3D contents after making the appropriate adjustments, you can enable this function and choose a set of 3D settings to memorize current 3D settings. • Apply 3D Settings: After the 3D settings are saved, you can decide if you would like to apply them by choosing a set of 3D settings that you have saved. Once applied, the projector will automatically play the incoming 3D contents if it matches the 3D settings saved. <p> Only the set(s) of 3D settings with memorized data is available.</p>
<p>HDMI Settings</p>	<ul style="list-style-type: none"> • HDMI Format: Selects a suitable color format to optimize display quality. <ul style="list-style-type: none"> • Auto: Automatically selects a suitable color space and gray level for the incoming HDMI signal. • Limited: Utilizes the Limited range RGB 16-235. • Full: Utilizes the Full range RGB 0-255. • HDMI Equalizer: Adjusts the equalizer gain settings for an HDMI signal. The higher the setting, the stronger the gain value. If there are more than one HDMI port on the projector, select the HDMI port first before adjusting the value. • HDMI EDID: Switch HDMI EDID between HDMI 1.4 or HDMI 2.0 in order to solve compatibility issue with uncertain old players. <ul style="list-style-type: none"> • Enhance: Enhanced mode can switch to HDMI 2.0 EDID • Standard: Standard mode can switch to HDMI 1.4 EDID.

Fast Mode	<p>Minimizing the response time (one frame) between the source input and the image output, this mode will enhance the controlling experience.</p> <p> When using Fast Mode:</p> <ul style="list-style-type: none"> • In order to have minimized response time, Keystone, Aspect Ratio, 2D Keystone, Corner Fit, Digital Zoom, Digital Shrink, Digital Image Shift, Blanking, Overscan, Display Resolution should be reset to factory preset value. • Recommend timings are 1280x800 60Hz/120Hz. See "Timing table" on page 54 for more details.
Reset Display	Returns all of the adjustments you've made for the Display menu to the factory preset values.

Installation



Projector Position	The projector can be installed on a ceiling or behind a screen, or with one or more mirrors. The options are Front, Front Ceiling, Rear and Rear Ceiling.
2D Keystone	Adjusts the shape of the projected image to ensure straight lines on all four corners. See " Correcting 2D Keystone " on page 27 for details.
Test Pattern	Adjusts the image size and focus and check that the projected image is free from distortion. 
High Altitude Mode	<p>We recommend you use the High Altitude Mode when your environment is between 1500 m –3000 m above sea level, and ambient temperature is between 0°C–30°C.</p> <p>Operation under "High Altitude Mode" may cause a higher decibel operating noise level because of increased fan speed necessary to improve overall system cooling and performance.</p> <p>If you use this projector under other extreme conditions excluding the above, it may display auto shut-down symptoms, which is designed to protect your projector from over-heating. In cases like this, you should switch to High Altitude mode to solve these symptoms. However, this is not to state that this projector can operate under any and all harsh or extreme conditions.</p> <p> Do not use the High Altitude Mode if your altitude is between 0 m and 1500 m and ambient temperature is between 0°C and 35°C. The projector will be over cooled, if you turn the mode on under such a condition.</p>
Baud Rate	Selects a baud rate that is identical with your computer's so that you can connect the projector using a suitable RS-232 cable and update or download the projector's firmware. This function is intended for qualified service personnel.
Corner Fit	<ul style="list-style-type: none"> • Top Left: To correct the top left corner. • Top Right: To correct the top right corner. • Bottom Left: To correct the bottom left corner. • Bottom Right: To correct the bottom right corner.

Image Resizing

Digital Zoom

Magnifies or reduces the projected image.

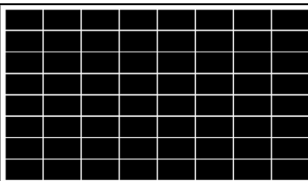
1. After the Zoom bar displays, press ▲ repeatedly to magnify the picture to a desired size.
2. To navigate the picture, press **OK** to switch to the panning mode and press the directional arrows (▲, ▼, ◀, ▶) on the projector or remote control to navigate the picture.
3. To reduce size of the picture, press **OK** to switch back to the zoom in/out function, and press **AUTO** to restore the picture to its original size. You can also press repeatedly until it is restored to the original size.



The picture can only be navigated after it is magnified. You can further magnify the picture while searching for details.

Digital Shrink & Shift

Shrinks and/or shifts the projected image.

1. After the adjustment bar displays, press ◀/▶ repeatedly to shrink or magnify the picture to a desired size.
2. Press **OK** to activate digital shift function.
3. After digital shift function is activated, press the directional arrows (▲, ▼, ◀, ▶) to shift the image.
4. Press **AUTO** to restore the picture to its original size.





The picture can only be shifted after it shrank.

Blanking

- **Modes of adjustment:**
- **Top:** To adjust the top blanking area on the projected picture
- **Bottom:** To adjust the bottom blanking area on the projected picture.
- **Left:** To adjust the left blanking area on the projected picture.
- **Right:** To adjust the right blanking area on the projected picture.
- **Reset all blanking settings:** To set up all Blanking settings to default.

System

Language	Sets the language for the On-Screen Display (OSD) menus.
Background Settings	<ul style="list-style-type: none"> • Background: Sets the background color for the projector. • Splash Screen: Allows you to select which logo screen will be displayed during projector start-up.
Menu Settings	<ul style="list-style-type: none"> • Menu Type: Switches to the Basic OSD menu. • Menu Display Time: Sets the length of time the OSD will remain active after your last key press.
Light Source Information	Shows the current light mode.
Standby Settings	<ul style="list-style-type: none"> • Standby Mode <ul style="list-style-type: none"> • ECO: The projector maintains at normal standby mode with less than 0.5W power consumption. • Network: The projector maintains at network standby mode with less than 2W power consumption. • Normal: Allows the projector to provide network, monitor out and audio pass through functions in standby mode. • Auto Disable Network Standby Mode: Allows the projector to disable the network function after a set period of time after it enters standby mode. For instance, if 20 min is selected, the projector is able to provide the network function for 20 minutes after it enters standby mode. When 20 minutes is up, the projector enters normal standby mode. If Off is selected, the projector will not provide the network function in standby mode. • Audio Pass Through: The projector can play sound when it is in standby mode and the corresponding jacks are correctly connected to devices. Press ◀▶ to choose the source that you wish to use. See "Connection" on page 22 for how to make the connection.
Operation Settings	<p>Reminder Message</p> <p>Sets the reminder messages on or off.</p>
	<p>Power On/Off Settings</p> <ul style="list-style-type: none"> • Direct Power On: Allows the projector to turn on automatically once the power is fed through the power cord. • Signal Power On: Sets whether to turn the projector directly on without pressing POWER or  ON when the projector is in standby mode and detects a VGA signal or a HDMI signal with 5V power. • Auto Power Off: Allows the projector to turn off automatically if no input signal is detected after a set period of time to prevent unnecessary waste of light source life.
Security Settings	See " Utilizing the password function " on page 30.

Network Settings	<ul style="list-style-type: none"> • Wired LAN • AMX Device Discovery: When this function is On, the projector can be detected by AMX controller. • MAC Address (Wired): Displays the mac address for this projector.
Factory Default	<p>Returns all settings to the factory preset values.</p>  The following settings will still remain: Keystone, Projector Installation, Light Usage Time, High Altitude Mode, Security Settings, Baud Rate, HDMI Equalizer, Digital Shrink & Shift, Filter Usage Time.
Reset System	<p>Returns all of the adjustments you've made for the System menu to the factory preset values.</p>

Information

Information	<ul style="list-style-type: none"> • Native Resolution: Shows the native resolution of the projector. • Detected Resolution: Shows the native resolution of the input signal. • Source: Shows the current signal source. • Picture Mode: Shows the selected mode in the Picture menu. • Light Source Mode: Shows the selected mode in the Light Settings menu. • 3D Format: Shows the current 3D mode. • Color System: Shows input system format. • Light Usage Time: Shows the number of hours the light source has been used. • Firmware Version: Shows the firmware version of your projector. • Service Code: Shows the projector serial number.
--------------------	--

Maintenance

Care of the projector

Your projector needs little maintenance. The only thing you need to do on a regular basis is to keep the lens clean.

Never remove any parts of the projector. Contact your dealer if other parts need replacing.

Cleaning the Projector Mirror

Remove the dust with a "Bellows/Lens Blower" readily available from camera shops to prevent scratching the mirror with subsequently wiped.



- Always turn the projector off and allow to cool for at least 30 minutes prior to cleaning.
- Never touch the projector mirror or Lens directly by hand.

Cleaning the lens

Clean the lens whenever you notice dirt or dust on the surface.

- Use a canister of compressed air to remove dust.
- If there is dirt or smears, use lens-cleaning paper or moisten a soft cloth with lens cleaner and gently wipe the lens surface.



Never use any type of abrasive pad, alkaline/acid cleaner, scouring powder, or volatile solvent, such as alcohol, benzene, thinner or insecticide. Using such materials or maintaining prolonged contact with rubber or vinyl materials may result in damage to the projector surface and cabinet material.

Cleaning the projector case

Before you clean the case, turn the projector off using the proper shutdown procedure as described in ["Shutting down the projector" on page 33](#) and unplug the power cord.

- To remove dirt or dust, wipe the case with a soft, lint-free cloth.
- To remove stubborn dirt or stains, moisten a soft cloth with water and a neutral pH detergent. Then wipe the case.



Never use wax, alcohol, benzene, thinner or other chemical detergents. These can damage the case.

Storing the projector

If you need to store the projector for an extended time, please follow the instructions below:

- Make sure the temperature and humidity of the storage area are within the recommended range for the projector. Please refer to ["Specifications" on page 53](#) or consult your dealer about the range.
- Retract the adjuster feet.
- Remove the battery from the remote control.
- Pack the projector in its original packing or equivalent.

Transporting the projector

It is recommended that you ship the projector with its original packing or equivalent. When you carry the projector yourself, please use the original box or a suitable soft carry case.

Indicators

POWER	TEMP	LIGHT SOURCE	STATUS
System Messages			
O			Stand-by
G			Powering up
G			Normal operation
O			Normal power-down cooling
R	R	R	Download
G		R	CW start fail
G		R	Phosphor Wheel start fail
O		R	Case open
O	G		Thermal break sensor error
Burn-In Messages			
G			Burn-in on
G	G	G	Burn-in off
Light source Error Messages			
		R	Light source 1 error in normal operation
		R	Light source is not lit up
Thermal Error Messages			
R	R		Fan 1 error (the actual fan speed is outside the desired speed)
R	R		Fan 2 error (the actual fan speed is outside the desired speed)
G	R		Temperature 1 error (over limited temperature)
G	R		Thermal Sensor 1 open error
G	G		Thermal Sensor 1 short error
G	G		Thermal IC #1 I2C Connection error
G	R		Temperature 2 error (over limited temperature)
G	R		Thermal Sensor 2 open error
G	G		Thermal Sensor 2 short error
G	G		Thermal IC #2 I2C Connection error
G	R	R	Temperature 3 error (over limited temperature)
G	R	R	Thermal Sensor 3 open error
G	R	G	Thermal Sensor 3 short error
G	R	G	Thermal IC #3 I2C Connection error

O : Static orange

G : Static green

R : Static red

O : Flashing orange (cycle : on 1 sec/off 1 sec)

G : Flashing green (cycle : on 1 sec/off 1 sec)

R : Flashing red (cycle : on 1 sec/off 1 sec)

Troubleshooting

Troubleshooting

? The projector does not turn on.

Cause	Remedy
There is no power from the power cable.	Plug the power cord into the AC inlet on the projector, and plug the power cord into the power outlet. If the power outlet has a switch, make sure that it is switched on.
Attempting to turn the projector on again during the cooling process.	Wait until the cooling down process has completed.

? No picture.

Cause	Remedy
The video source is not turned on or connected correctly.	Turn the video source on and check that the signal cable is connected correctly.
The projector is not correctly connected to the input signal device.	Check the connection.
The input signal has not been correctly selected.	Select the correct input signal with the SOURCE key on the projector or remote control.

? Blurred image.

Cause	Remedy
The projection lens is not correctly focused.	Adjust the focus of the lens using the focus ring.
The projector and the screen are not aligned properly.	Adjust the projection angle and direction as well as the height of the unit if necessary.

? Remote control does not work.

Cause	Remedy
The battery is out of power.	Replace the battery with new one.
There is an obstacle between the remote control and the projector.	Remove the obstacle.
You are too far away from the projector.	Stand within 7 meters (23 feet) of the projector.

? The password is incorrect.

Cause	Remedy
You do not remember the password.	lease see "Entering the password recall procedure" on page 31 for details.

Specifications

Projector specifications



All specifications are subject to change without notice.

Optical

Resolution

- LW855UST
1280 x 800 WXGA
- LH856UST
1920 x 1080 1080p

Display system

- Single-chip DLP™ system

Lens

- F = 2.5, f = 5.1 mm

Light source

- Laser diodes

Electrical

Power supply

- AC100-240V, 2.0A
- 50-60 Hz (Automatic)

Power consumption

- 200W (Max); < 0.5W (Standby); < 2W (When the network function in the standby settings is on)

Mechanical

Weight

- 14.7 lbs (6.5 Kg) (without lens)

Dimension

- 317.2mm (W) x 208.0 (H) x 376.4 (D) mm
(12.49"x8.19"x14.82")

Output terminals

Speaker

- 10 watt x 2

Audio signal output

- PC audio jack x 1

Monitor Out

- D-Sub 15-pin (female) x1

Control

USB

- Type-B mini USB
(Optional for PointWrite kit)
- Type-A power supply 1.5A

RS-232 serial control

- 9 pin x 1 (In)

IR receiver x 1 (Front)

LAN control

- RJ45 x 1 (10/100Mbps)

Input terminals

Computer input

- RGB input
D-Sub 15-pin (female) x 1

Digital - HDMI 2 x 1

Audio signal input

- Audio in
PC audio jack x 1
Microphone in jack x 1

Environmental Requirements

Temperature

- Operating: 0°C–40°C at sea level
- Storage: -20°C–60°C at sea level

Relative humidity

- Operating: 10%–90% (without condensation)
- Storage: 10%–90% (without condensation)

Transporting

Original packing or equivalent is recommended.

Repairing

Please visit below website and choose your country to find your service contact window. <http://www.benq.com/welcome>

Timing table

Support video timing for HDMI input

Timing	Resolution	Horizontal frequency (kHz)	Vertical frequency (Hz)	Dot Clock Frequency (MHz)	3D Frame Sequential	3D frame packing	3D over-under	3D side-by-side
480i	720(1440) x 480	15.73	59.94	27	⊙			
480p	720 x 480	31.47	59.94	27	⊙			
576i	720(1440) x 576	15.63	50	27				
576p	720 x 576	31.25	50	27				
720/50p	1280 x 720	37.5	50	74.25		⊙	⊙	⊙
720/60p	1280 x 720	45	60	74.25	⊙	⊙	⊙	⊙
1080/24P	1920 x 1080	27	24	74.25		⊙	⊙	⊙
1080/25P	1920 x 1080	28.13	25	74.25				
1080/30P	1920 x 1080	33.75	30	74.25				
1080/50i	1920 x 1080	28.13	50	74.25				⊙
1080/60i	1920 x 1080	33.75	60	74.25				⊙
1080/50P	1920 x 1080	56.25	50	148.5			⊙	⊙
1080/60P	1920 x 1080	67.5	60	148.5	⊙		⊙	⊙
2160/24P	3840 x 2160	54	24	297				
2160/25P	3840 x 2160	56.25	25	297				
2160/30P	3840 x 2160	67.5	30	297				
2160/50P	3840 x 2160	112.5	50	594				
2160/60P	3840 x 2160	135	60	594				

Support PC timing for HDMI input

Resolution	Mode	Refresh rate (Hz)	Horizontal frequency (kHz)	Clock (MHz)	3D Frame Sequential	3D over-under	3D side-by-side
640 x 480	VGA_60	59.94	31.469	25.175	⊙	⊙	⊙
	VGA_72	72.809	37.861	31.5			
	VGA_75	75	37.5	31.5			
	VGA_85	85.008	43.269	36			
	VGA_120**	119.518	61.91	52.5			
720 x 400	720x400_70	70.087	31.469	28.3221			

Resolution	Mode	Refresh rate (Hz)	Horizontal frequency (kHz)	Clock (MHz)	3D Frame Sequential	3D over-under	3D side-by-side
800 x 600	SVGA_60	60.317	37.879	40	⊙	⊙	⊙
	SVGA_72	72.188	48.077	50			
	SVGA_75	75	46.875	49.5			
	SVGA_85	85.061	53.674	56.25			
	SVGA_120 (Reduce Blanking)	119.854	77.425	83	⊙		
1024 x 768	XGA_60	60.004	48.363	65	⊙	⊙	⊙
	XGA_70	70.069	56.476	75			
	XGA_75	75.029	60.023	78.75			
	XGA_85	84.997	68.667	94.5			
	XGA_120 (Reduce Blanking)	119.989	97.551	115.5	⊙		
1152 x 864	1152 x 864_75	75	67.5	108			
1024x576	BenQ Notebook Timing	60	35.82	46.996			
1024x600	BenQ Notebook Timing	64.995	41.467	51.419			
1280x720	1280 x 720_60	60	45	74.25	⊙	⊙	⊙
1280 x 768	1280 x 768_60	59.87	47.776	79.5	⊙	⊙	⊙
1280 x 800	WXGA_60	59.81	49.702	83.5	⊙	⊙	⊙
	WXGA_75	74.934	62.795	106.5			
	WXGA_85	84.88	71.554	122.5			
	WXGA_120 (Reduce Blanking)	119.909	101.563	146.25	⊙		
1280 x 1024	SXGA_60	60.02	63.981	108		⊙	⊙
	SXGA_75	75.025	79.976	135			
	SXGA_85	85.024	91.146	157.5			
1280 x 960	1280 x 960_60	60	60	108		⊙	⊙
	1280 x 960_85	85.002	85.938	148.5			
1360 x 768	1360 x 768_60	60.015	47.712	85.5		⊙	⊙
1440 x 900	WXGA+_60	59.887	55.935	106.5		⊙	⊙
1400X1050	SXGA+_60	59.978	65.317	121.75		⊙	⊙
1600x1200	UXGA	60	75	162		⊙	
1680x1050	1680x1050_60	59.954	65.29	146.25		⊙	⊙
640x480 @67Hz	MACI3	66.667	35	30.24			
832x624 @75Hz	MACI6	74.546	49.722	57.28			
1024x768 @75Hz	MACI9	75.02	60.241	80			
1152x870 @75Hz	MAC2I	75.06	68.68	100			

Resolution	Mode	Refresh rate (Hz)	Horizontal frequency (kHz)	Clock (MHz)	3D Frame Sequential	3D over-under	3D side-by-side
1920x1080 @60HZ	1920X1080_60	60	67.5	148.5	⊙	⊙	⊙
1920x1200 @60HZ	1920X1200_60 (Reduce Blanking)	59.95	74.038	154	⊙	⊙	⊙
"1920x1080 @120Hz"	1920X1080_120	120	135	297			
"1920x1200 @120Hz"	1920X1200_120 (Reduce Blanking)	119.909	152.404	317			
3840x2160	3840X2160_30 (Reduce Blanking)	29.97	65.66	257.404			
3840x2160	3840X2160_60 (Reduce Blanking)	59.94	133.187	522.092			
3840x2160	3840X2160_30	30	67.5	297			
3840x2160	3840X2160_60	60	135	594			

Support PC timing for PC input

Resolution	Mode	Refresh rate (Hz)	H-frequency (kHz)	Clock (MHz)	3D Field	3D over-under	3D side-by-side
720 x 400	720x400_70	70.087	31.469	28.3221			
640 x 480	VGA_60	59.94	31.469	25.175	⊙	⊙	⊙
	VGA_72	72.809	37.861	31.5			
	VGA_75	75	37.5	31.5			
	VGA_85	85.008	43.269	36			
800 x 600	SVGA_60	60.317	37.879	40	⊙	⊙	⊙
	SVGA_72	72.188	48.077	50			
	SVGA_75	75	46.875	49.5			
	SVGA_85	85.061	53.674	56.25			
1024 x 768	XGA_60	60.004	48.363	65	⊙	⊙	⊙
	XGA_70	70.069	56.476	75			
	XGA_75	75.029	60.023	78.75			
	XGA_85	84.997	68.667	94.5			
1152 x 864	1152 x 864_75	75	67.5	108			
1024 x 576	BenQ NB Timing	60	35.82	46.966			
1024 x 600	BenQ NB Timing	64.995	41.467	51.419			
1280x720	1280 x 720_60	60	45	74.25	⊙	⊙	⊙
1280 x 768	1280 x 768_60	59.87	47.776	79.5	⊙	⊙	⊙

Resolution	Mode	Refresh rate (Hz)	H-frequency (kHz)	Clock (MHz)	3D Field	3D over-under	3D side-by-side
1280 x 800	WXGA_60	59.81	49.702	83.5	⊙	⊙	⊙
	WXGA_75	74.934	62.795	106.5			
	WXGA_85	84.88	71.554	122.5			
1280 x 1024	SXGA_60	60.02	63.981	108		⊙	⊙
	SXGA_75	75.025	79.976	135			
	SXGA_85	85.024	91.146	157.5			
1280 x 960	1280 x 960_60	60	60	108		⊙	⊙
	1280 x 960_85	85.002	85.938	148.5			
1360 x 768	1360 x 768_60	60.015	47.712	85.5		⊙	⊙
1440 x 900	WXGA+_60	59.887	55.935	106.5		⊙	⊙
1400x1050	SXGA+_60	59.978	65.317	121.75		⊙	⊙
1600x1200	UXGA	60	75	162		⊙	⊙
1680 x 1050	1680x1050_60	59.954	65.29	146.25		⊙	⊙
640x480 @67Hz	MAC13	66.667	35	30.24			
832x624 @75Hz	MAC16	74.546	49.722	57.28			
1024x768 @75Hz	MAC19	74.93	60.241	80			
1152x870 @75Hz	MAC21	75.06	68.68	100			
1920x1080 @60HZ	1920X1080_60	60	67.5	148.5	⊙	⊙	⊙
1920x1200 @60HZ	1920X1200_60 (Reduce Blanking)	59.95	74.038	154	⊙	⊙	⊙

 **Note:**

- There timing showing depend the EDID file and VGA graphic card limitation. It is possible that user cannot choose the above timings on VGA display card.

True 3D Video Compatibility table

Input Resolutions	HDMI I.4a 3D Input	Input timing		
		1280 X 720P @ 50Hz	Top - and - Bottom	
		1280 X 720P @ 60Hz	Top - and - Bottom	
		1280 X 720P @ 50Hz	Frame packing	
		1280 X 720P @ 60Hz	Frame packing	
		1920 X 1080i @50 Hz	Side- by-Side (Half)	
		1920 X 1080i @60 Hz	Side- by-Side (Half)	
		1920 X 1080P @24 Hz	Top - and – Bottom	
		1920 X 1080P @24 Hz	Frame packing	
	HDMI I.3	1920 x 1080i @ 50Hz	Side-by-Side(Half)	SBS mode is on
		1920 x1080i @ 60Hz		
		1280 x 720P @50Hz		
		1280 x 720P @60Hz		
			Top-and-Bottom	TAB mode is on
		1920 x 1080i @ 50Hz		
		1920 x1080i @ 60Hz		
		1280 x 720P @50Hz		
		480i	HQFS	3D format is Frame sequential

*When testing 3D, please confirm that the glasses must support up to 144Hz

RS232 command control

Function	Type	Operation	ASCII
Power	Write	Power On	<CR>*pow=on#<CR>
	Write	Power off	<CR>*pow=off#<CR>
	Read	Power Status	<CR>*pow=?#<CR>
Source Selection	Write	COMPUTER/YPbPr	<CR>*sour=RGB#<CR>
	Write	HDMI(MHL)	<CR>*sour=hdmi#<CR>
	Write	HDMI 2(MHL2)	<CR>*sour=hdmi2#<CR>
	Read	Current source	<CR>*sour=?#<CR>

Function	Type	Operation	ASCII
Audio Control	Write	Mute On	<CR>*mute=on#<CR>
	Write	Mute Off	<CR>*mute=off#<CR>
	Read	Mute Status	<CR>*mute=?#<CR>
	Write	Volume +	<CR>*vol=+#<CR>
	Write	Volume -	<CR>*vol=-#<CR>
	Write	Volume level for customer	<CR>*vol=value#<CR>
	Read	Volume Status	<CR>*vol=?#<CR>
	Write	Mic. Volume +	<CR>*micvol=+#<CR>
	Write	Mic. Volume -	<CR>*micvol=-#<CR>
	Read	Mic. Volume Status	<CR>*micvol=?#<CR>
Audio Source Select	Write	Audio pass Through off	<CR>*audiosour=off#<CR>
	Write	Audio-Computer1	<CR>*audiosour=RGB#<CR>
	Write	Audio-HDMI	<CR>*audiosour=hdmi#<CR>
	Write	Audio-HDMI2	<CR>*audiosour=hdmi2#<CR>
	Write	Microphone	<CR>*audiosour=microphone#<CR>
	Read	Audio pass Status	<CR>*audiosour=?#<CR>
Picture Mode	Write	Presentation	<CR>*appmod=preset#<CR>
	Write	sRGB	<CR>*appmod=srgb#<CR>
	Write	Bright	<CR>*appmod=bright#<CR>
	Write	User1	<CR>*appmod=user1#<CR>
	Write	User2	<CR>*appmod=user2#<CR>
	Write	3D	<CR>*appmod=threed#<CR>
	Write	HDR10	<CR>*appmod=hdr<CR>
	Write	HLG	<CR>*appmod=hlg<CR>
	Write	Spreadsheet	<CR>*appmod=spreadsheet#<CR>
	Write	Video	<CR>*appmod=video<CR>
	Read	Picture Mode	<CR>*appmod=?#<CR>
Picture Setting	Write	Contrast +	<CR>*con=+#<CR>
	Write	Contrast -	<CR>*con=-#<CR>
	Write	Set Contrast value	<CR>*con=value#<CR>
	Read	Contrast value	<CR>*con=?#<CR>
	Write	Brightness +	<CR>*bri=+#<CR>
	Write	Brightness -	<CR>*bri=-#<CR>
	Write	Set Brightness value	<CR>*bri=value#<CR>
	Read	Brightness value	<CR>*bri=?#<CR>
	Write	Color +	<CR>*color=+#<CR>

Function	Type	Operation	ASCII
Picture Setting	Write	Color -	<CR>*color=-#<CR>
	Write	Set Color value	<CR>*color=value#<CR>
	Read	Color value	<CR>*color=?#<CR>
	Write	Sharpness +	<CR>*sharp=+#<CR>
	Write	Sharpness -	<CR>*sharp=-#<CR>
	Write	Set Sharpness value	<CR>*sharp=value#<CR>
	Read	Sharpness value	<CR>*sharp=?#<CR>
	Write	Color Temperature-Warm	<CR>*ct=warm#<CR>
	Write	Color Temperature-Normal	<CR>*ct=normal#<CR>
	Write	Color Temperature-Cool	<CR>*ct=cool#<CR>
	Read	Color Temperature Status	<CR>*ct=?#<CR>
	Write	Aspect 4:3	<CR>*asp=4:3#<CR>
	Write	Aspect 16:9	<CR>*asp=16:9#<CR>
	Write	Aspect 16:10	<CR>*asp=16:10#<CR>
	Write	Aspect Auto	<CR>*asp=AUTO#<CR>
	Read	Aspect Status	<CR>*asp=?#<CR>
	Write	Vertical Keystone +	<CR>*vkeystone=+#<CR>
	Write	Vertical Keystone -	<CR>*vkeystone=-#<CR>
	Write	Set Vertical Keystone value	<CR>*vkeystone=value#<CR>
	Read	Vertical Keystone value	<CR>*vkeystone=?#<CR>
	Write	Horizontal Keystone +	<CR>*hkeystone=+#<CR>
	Write	Horizontal Keystone -	<CR>*hkeystone=-#<CR>
	Write	Set Horizontal Keystone value	<CR>*hkeystone=value#<CR>
	Read	Horizontal Keystone value	<CR>*hkeystone=?#<CR>
	Write	4 Corners Top-Left-X Decrease	<CR>*cornerfittlx=-#<CR>
	Write	4 Corners Top-Left-X Increase	<CR>*cornerfittlx=+#<CR>
	Read	4 Corners Top-Left-X Status	<CR>*cornerfittlx=?#<CR>
	Write	4 Corners Top-Left-Y Decrease	<CR>*cornerfittly=-#<CR>
	Write	4 Corners Top-Left-Y Increase	<CR>*cornerfittly=+#<CR>
	Read	4 Corners Top-Left-Y Status	<CR>*cornerfittly=?#<CR>
	Write	4 Corners Top-Right-X Decrease	<CR>*cornerfittrx=-#<CR>
	Write	4 Corners Top-Right-X Increase	<CR>*cornerfittrx=+#<CR>
	Read	4 Corners Top-Right-X Status	<CR>*cornerfittrx=?#<CR>
Write	4 Corners Top-Right-Y Decrease	<CR>*cornerfity=-#<CR>	
Write	4 Corners Top-Right-Y Increase	<CR>*cornerfity=+#<CR>	
Read	4 Corners Top-Right-Y Status	<CR>*cornerfity=?#<CR>	

Function	Type	Operation	ASCII
Picture Setting	Write	4 Corners Bottom-Left-X Decrease	<CR>*cornerfitblx=-#<CR>
	Write	4 Corners Bottom-Left-X Increase	<CR>*cornerfitblx=+#<CR>
	Read	4 Corners Bottom-Left-X Status	<CR>*cornerfitblx=?#<CR>
	Write	4 Corners Bottom-Left-Y Decrease	<CR>*cornerfitbly=-#<CR>
	Write	4 Corners Bottom-Left-Y Increase	<CR>*cornerfitbly=+#<CR>
	Read	4 Corners Bottom-Left-Y Status	<CR>*cornerfitbly=?#<CR>
	Write	4 Corners Bottom-Right-X Decrease	<CR>*cornerfitbrx=-#<CR>
	Write	4 Corners Bottom-Right-X Increase	<CR>*cornerfitbrx=+#<CR>
	Read	4 Corners Bottom-Right-X Status	<CR>*cornerfitbrx=?#<CR>
	Write	4 Corners Bottom-Right-Y Decrease	<CR>*cornerfitbry=-#<CR>
	Write	4 Corners Bottom-Right-Y Increase	<CR>*cornerfitbry=+#<CR>
	Read	4 Corners Bottom-Right-Y Status	<CR>*cornerfitbry=?#<CR>
	Write	Digital Zoom In	<CR>*zoomI#<CR>
	Write	Digital Zoom out	<CR>*zoomO#<CR>
	Write	Auto	<CR>*auto#<CR>
	Write	Brilliant color +	<CR>*BC=+#<CR>
	Write	Brilliant color -	<CR>*BC=-#<CR>
	Write	Brilliant color set value	<CR>*BC=value#<CR>
	Read	Brilliant color status	<CR>*BC=?#<CR>
	Write	Reset picture settings	<CR>*rstpicsetting#<CR>
Operation Settings	Write	Projector Position-Front Table	<CR>*pp=FT#<CR>
	Write	Projector Position-Rear Table	<CR>*pp=RE#<CR>
	Write	Projector Position-Rear Ceiling	<CR>*pp=RC#<CR>
	Write	Projector Position-Front Ceiling	<CR>*pp=FC#<CR>
	Read	Projector Position Status	<CR>*pp=?#<CR>
	Write	Quick auto search	<CR>*QAS=on#<CR>
	Write	Quick auto search	<CR>*QAS=off#<CR>
	Read	Quick auto search status	<CR>*QAS=?#<CR>
	Write	Direct Power On-on	<CR>*directpower=on#<CR>
	Write	Direct Power On-off	<CR>*directpower=off#<CR>
	Read	Direct Power On-Status	<CR>*directpower=?#<CR>
	Write	Signal Power On-on	<CR>*autopower=on#<CR>
	Write	Signal Power On-off	<CR>*autopower=off#<CR>
	Read	Signal Power On-Status	<CR>*autopower=?#<CR>

Function	Type	Operation	ASCII
Baud Rate	Write	9600	<CR>*baud=9600#<CR>
	Write	14400	<CR>*baud=14400#<CR>
	Write	19200	<CR>*baud=19200#<CR>
	Write	38400	<CR>*baud=38400#<CR>
	Write	57600	<CR>*baud=57600#<CR>
	Write	115200	<CR>*baud=115200#<CR>
	Read	Current Baud Rate	<CR>*baud=?#<CR>
Lamp Control	Read	Lamp Hour	<CR>*ltim=?#<CR>
	Write	Normal mode	<CR>*lampm=lnor#<CR>
	Write	Eco mode	<CR>*lampm=eco#<CR>
	Write	Dynamic Dimming mode	<CR>*lampm=dynamicdimming#<CR>
	Write	Custom mode	<CR>*lampm=custom#<CR>
	Write	Light level for custom mode	<CR>*lampcustom=value#<CR>
	Read	Light level status for custom mode	<CR>*lampcustom=?#<CR>
	Read	Lamp Mode Status	<CR>*lampm=?#<CR>
Miscellaneous	Read	Model Name	<CR>*modelname=?#<CR>
	Read	System F/W Version	<CR>*sysfwversion=?#<CR>
	Read	Scaler F/W Version	<CR>*scalerfwversion=?#<CR>
	Read	Lan F/W Version	<CR>*lanfwversion=?#<CR>
	Read	MCU F/W Version	<CR>*mcutfwversion=?#<CR>
	Write	Blank On	<CR>*blank=on#<CR>
	Write	Blank Off	<CR>*blank=off#<CR>
	Read	Blank Status	<CR>*blank=?#<CR>
	Write	Freeze On	<CR>*freeze=on#<CR>
	Write	Freeze Off	<CR>*freeze=off#<CR>
	Read	Freeze Status	<CR>*freeze=?#<CR>
	Write	Menu On	<CR>*menu=on#<CR>
	Write	Menu Off	<CR>*menu=off#<CR>
	Read	Menu Status	<CR>*menu=?#<CR>
	Write	Up	<CR>*up#<CR>
	Write	Down	<CR>*down#<CR>
	Write	Right	<CR>*right#<CR>
	Write	Left	<CR>*left#<CR>
	Write	Enter	<CR>*enter#<CR>
	Write	Back	<CR>*back#<CR>
	Write	Source Menu On	<CR>*sourmenu=on#<CR>

Function	Type	Operation	ASCII
Miscellaneous	Write	Source Menu Off	<CR>*sourmenu=off#<CR>
	Read	Source Menu Status	<CR>*sourmenu=?#<CR>
	Write	3D Sync Off	<CR>*3d=off#<CR>
	Write	3D Auto	<CR>*3d=auto#<CR>
	Write	3D Sync Top Bottom	<CR>*3d=tb#<CR>
	Write	3D Sync Frame Sequential	<CR>*3d=fs#<CR>
	Write	3D Frame packing	<CR>*3d=fp#<CR>
	Write	3D Side by side	<CR>*3d=sbs#<CR>
	Write	3D inverter disable	<CR>*3d=da#<CR>
	Write	3D inverter	<CR>*3d=iv#<CR>
	Read	3D Sync Status	<CR>*3d=?#<CR>
	Write	AMX Device Discovery-on	<CR>*amxdd=on#<CR>
	Write	AMX Device Discovery-off	<CR>*amxdd=off#<CR>
	Read	AMX Device Discovery Status	<CR>*amxdd=?#<CR>
	Read	Mac Address	<CR>*macaddr=?#<CR>
	Read	Serial Number	<CR>*serialnumber=?#<CR>
	Write	High Altitude mode on	<CR>*Highaltitude=on#<CR>
	Write	High Altitude mode off	<CR>*Highaltitude=off#<CR>
	Read	High Altitude mode status	<CR>*Highaltitude=?#<CR>
	Color Calibration	Write	Tint +
Write		Tint -	<CR>*tint=-.#<CR>
Write		Set Tint value	<CR>*tint=value#<CR>
Read		Get Tint value	<CR>*tint=?#<CR>
Write		Set gamma value	<CR>*gamma=value#<CR>
Read		Gamma value status	<CR>*gamma=?#<CR>
Write		Set HDR Brightness value	<CR>*hdrbri=value#<CR>
Read		Get HDR Brightness value	<CR>*hdrbri=?#<CR>
Write		Red Gain +	<CR>*RGain=+#<CR>
Write		Red Gain -	<CR>*RGain=-.#<CR>
Write		Set Red Gain value	<CR>*RGain=value#<CR>
Read		Get Red Gain value	<CR>*RGain=?#<CR>
Write		Green Gain +	<CR>*GGain=+#<CR>
Write		Green Gain -	<CR>*GGain=-.#<CR>
Write		Set Green Gain value	<CR>*GGain=value#<CR>
Read		Get Green Gain value	<CR>*GGain=?#<CR>
Write		Blue Gain +	<CR>*BGain=+#<CR>

Function	Type	Operation	ASCII
Color Calibration	Write	Blue Gain -	<CR>*BGain=-#<CR>
	Write	Set Blue Gain value	<CR>*BGain=value#<CR>
	Read	Get Blue Gain value	<CR>*BGain=?#<CR>
	Write	Red Offset +	<CR>*ROffset=+#<CR>
	Write	Red Offset -	<CR>*ROffset=-#<CR>
	Write	Set Red Offset value	<CR>*ROffset=value#<CR>
	Read	Get Red Offset value	<CR>*ROffset=?#<CR>
	Write	Green Offset +	<CR>*GOffset=+#<CR>
	Write	Green Offset -	<CR>*GOffset=-#<CR>
Color Calibration	Write	Set Green Offset value	<CR>*GOffset=value#<CR>
	Read	Get Green Offset value	<CR>*GOffset=?#<CR>
	Write	Blue Offset +	<CR>*BOffset=+#<CR>
	Write	Blue Offset -	<CR>*BOffset=-#<CR>
	Write	Set Blue Offset value	<CR>*BOffset=value#<CR>
	Read	Get Blue Offset value	<CR>*BOffset=?#<CR>
	Write	Primary Color	<CR>*primcr=value#<CR>
	Read	Primary Color Status	<CR>*primcr=?#<CR>
	Write	Hue +	<CR>*hue=+#<CR>
	Write	Hue -	<CR>*hue=-#<CR>
	Write	Set Hue value	<CR>*hue=value#<CR>
	Read	Get Hue value	<CR>*hue=?#<CR>
	Write	Saturation +	<CR>*saturation=+#<CR>
	Write	Saturation -	<CR>*saturation=-#<CR>
	Write	Set Saturation value	<CR>*saturation=value#<CR>
	Read	Get Saturation value	<CR>*saturation=?#<CR>
	Write	Gain +	<CR>*gain=+#<CR>
	Write	Gain -	<CR>*gain=-#<CR>
	Write	Set Gain value	<CR>*gain=value#<CR>
	Read	Get Gain value	<CR>*gain=?#<CR>
Service	Read	Error Code report	<CR>*error=report#<CR>
	Read	FAN 1 speed	<CR>*fan1=?#<CR>
	Read	FAN 2 speed	<CR>*fan2=?#<CR>
	Read	Temperature 1	<CR>*tmp1=?#<CR>
	Read	Temperature 2	<CR>*tmp2=?#<CR>
	Read	Temperature 3	<CR>*tmp3=?#<CR>
	Read	LED indicator	<CR>*led=?#<CR>

PJLink

PJLink protocol

The network function of this projector support the PJLink class I, and the PJLink protocol can be used to perform projector setting and projector status query operations from a computer.

Control commands

The following table lists the PJLink protocol commands that can be used to control the projector.

- x characters in table are non-specific characters.

Command	Control Details	Parameter/ Return String	Remark	
POWR	Power supply control	0 1	Standby Power on	
POWR?	Power supply status query	0 1	Standby Power on	
INPT	Input selection	11	PCI / YPbPrI	
INPT?	Input status query	31 32	HDMI1 HDMI2	
AVMT	Mute	11	Video mute On	
AVMT?	Mute query	10 21 20 31 30	Video mute Off Audio mute On Audio mute Off Video & Audio mute On Video & Audio mute Off	
ERST?	Error status query	xxxxxx	1st byte 2nd byte 3rd byte 4th byte 5th byte 6th byte	Indicates fan errors, and returns 0 - 2 Indicates light source errors, and returns 0 - 2 Indicates temperature errors, and returns 0 - 2 Return 0 Return 0 Indicates other errors, and returns 0 - 2
LAMP?	Light source status query	xxxxxxxxxxxx	1st number (1-5 digitals): Light source 1 runtime	
INST?	Input selection list query	11 31 32	LW855UST/LH856UST	
NAME?	Projector name query	xxxxx	Returns the name set in [PROJECTOR NAME] of [NETWORK SETUP]	

Command	Control Details	Parameter/ Return String	Remark
INF1?	Manufacturer name query	BenQ	Returns manufacturer name
INF2?	Model name query	LW855UST/ LH856UST	Returns model name
INF0?	Other information queries	xxxxx	Returns information such as version number
CLASS?	Class information query	I	Returns class for PJLink